

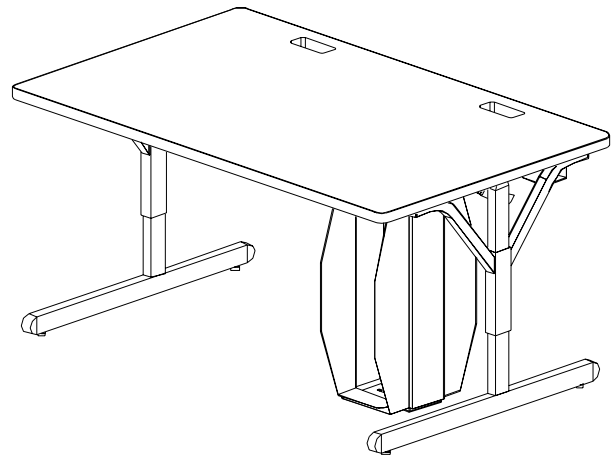

**35XTC21 35XTC15
35XTC23 35XTC25**

**Adjustable Work Center with
CPU Holder and Glides
(30" DEPTH ONLY)
Assembly Instructions**



**35XTC21 36" wide one grommet hole
35XTC15 42" wide one grommet hole**

35XTC23 48" wide two grommet holes

Parts List

Qty.	Part No.	Description
1	SA2339	Table Top (36")
	SA2340	Table Top (42")
	SA2341	Table Top (48")
	SA2342	Table Top (72")
2	022-2037	Leg Assembly - Lower
1	022-1589	Leg Assembly - Upper Right
1	022-1590	Leg Assembly - Upper Left
1	010-2321	Modesty Panel (36")
	010-3080	Modesty Panel (42")
	010-2324	Modesty Panel (48")
	010-2706	Modesty Panel (72")
1	010-2322	Cord Bin (36")
	010-3081	Cord Bin (42")
	010-2325	Cord Bin (48")
	010-3075	Cord Bin (72")
2	010-3344	CPU Side Holder-w/hole (1 required on 35XTC15, 35XTC21 & 35XTC23)
	010-4981	CPU Holder w/Hole for MT Models
2	010-3343	CPU Side Holder-w/slot (1 required on 35XTC15, 35XTC21 & 35XTC23)
	010-4980	CPU Holder w/slot for MT Models

Hardware List

Qty.	Ref.	Part No.	Description
12	AA	030-0402	#10-32 x 5/8" Combo Screw
12	BB	030-0240	Washer, External Tooth
4	CC	030-0396	3/8-16 x 1/2" Set Screw
4	DD	030-0325	1/4-20 x 1/2" Combo Screw
6	EE	030-0168	#8 x 1/2" Wood Screw
2	FF	030-0433	#10-32 x 1/2" Knurled Knob Screw
2	HH	030-0465	Retaining Washer - Nylon
4	JJ	015-0045	Glide, Leg
8	KK	030-0305	Washer, Flat (6 required on 35XTC15, 35XTC21 & 35XTC23)
8	LL	030-0453	#12 x 3/4" Phillips Truss Head Screw (4 required on 35XTC15, 35XTC21 & 35XTC23)
2	MM	030-0272	1/4-20 x 1/2" Carriage Bolt (1 required on 35XTC15, 35XTC21 & 35XTC23)
2	NN	030-0306	Washer, Flat (1 required on 35XTC15, 35XTC21 & 35XTC23)
2	PP	030-0256	1/4-20 Flanged Nut (1 required on 35XTC15, 35XTC21 & 35XTC23)
1		030-0397	Allen Wrench

Tools Required

- Phillips Screwdriver
- Allen Wrench (provided)
- 7/16" Open/Box End Wrench
- Electric Drill
- 1/8" Dia. Drill Bit

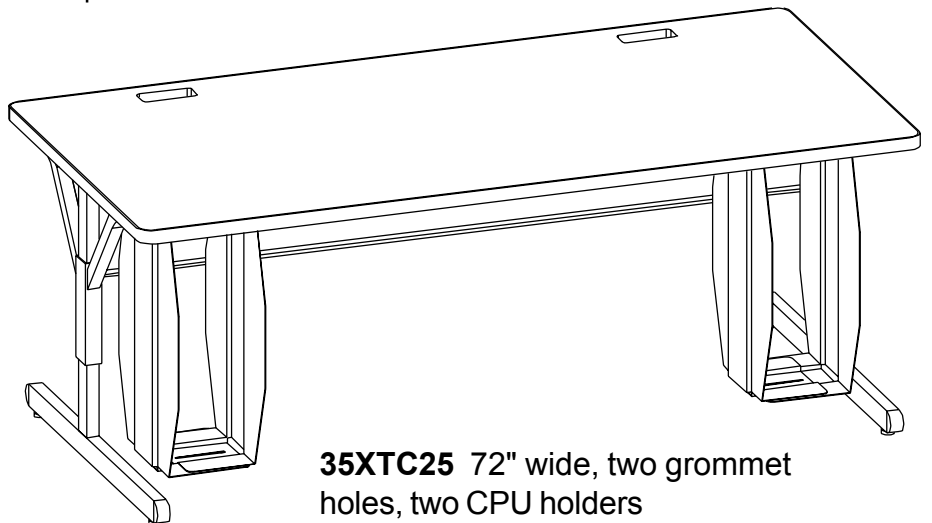

**35XTC25 72" wide, two grommet
holes, two CPU holders**

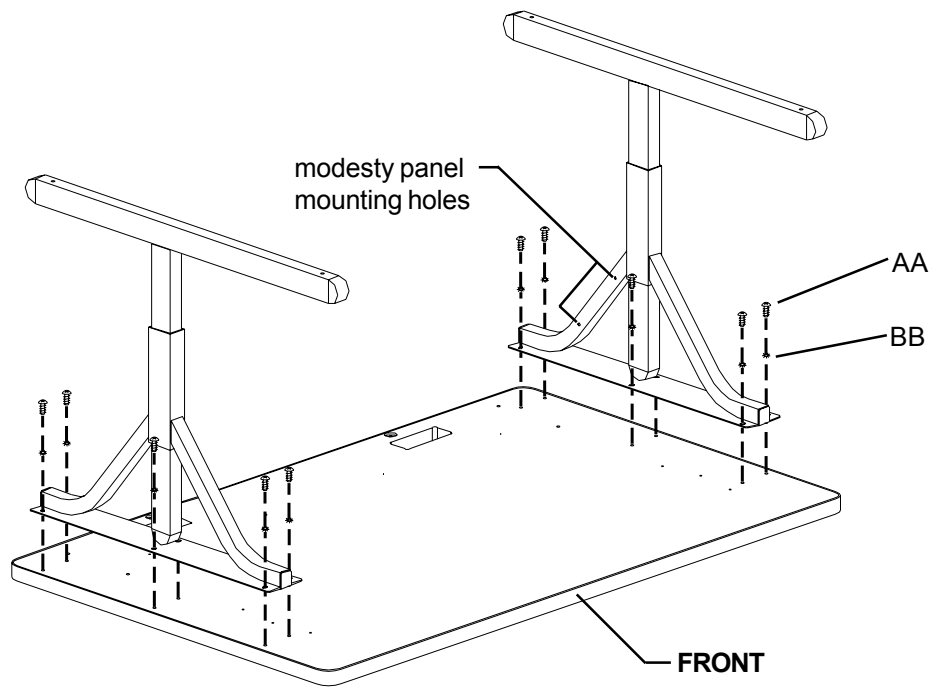

Step 1

Lay the table top on a carpeted surface with holes facing up. Position the legs onto the table top with the modesty panel mounting holes facing inward as shown. Loosely attach legs with screws (AA) and washers (BB).

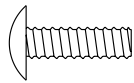

AA



BB

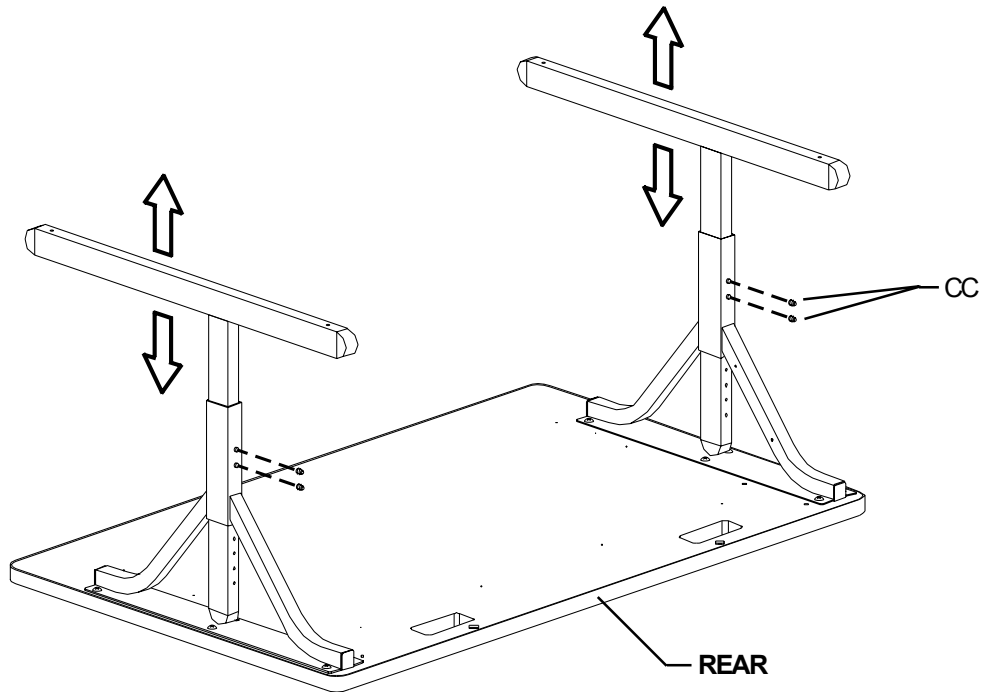

Step 2

Set desired height of legs and insert set screws (CC) into legs and tighten with allen wrench provided.



CC

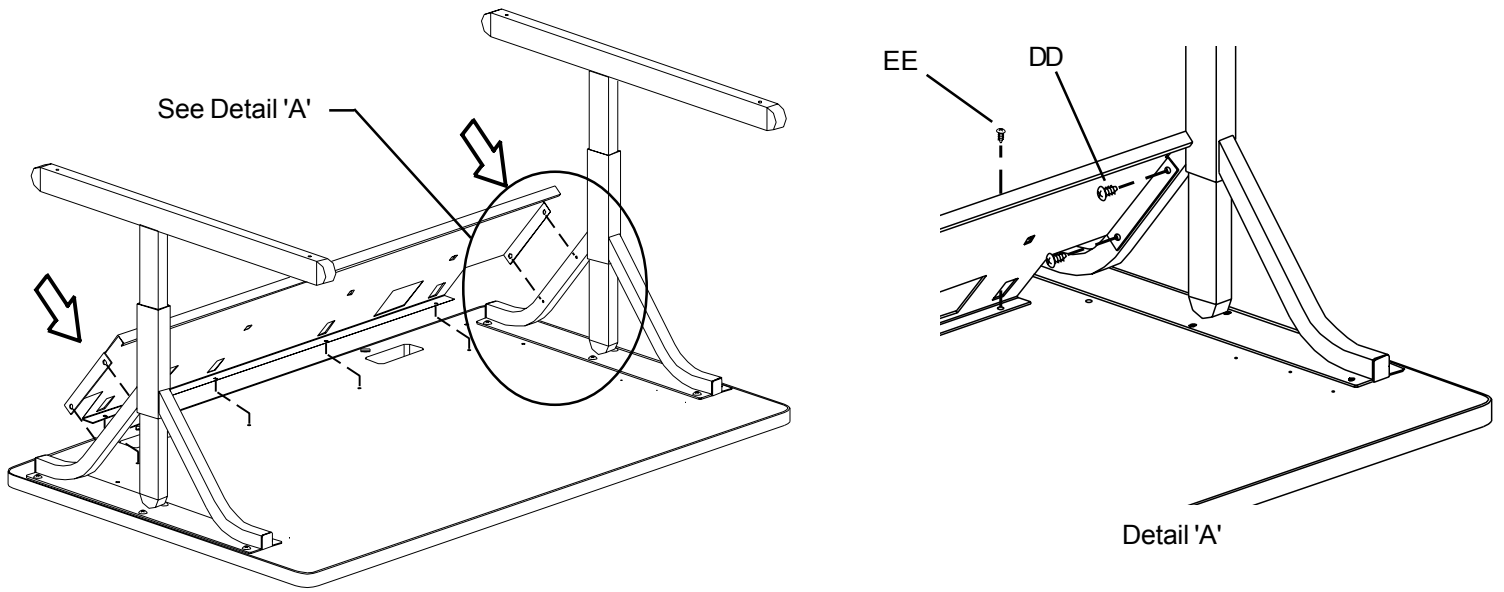

Step 3

Slide the modesty panel between the two legs. Align the modesty panel mounting holes with the leg mounting holes. Loosely install screws (DD). Secure the modesty panel to the table top with screws (EE) as shown in Detail 'A'. **Tighten all screws.**

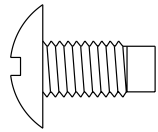

DD

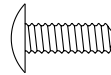

EE

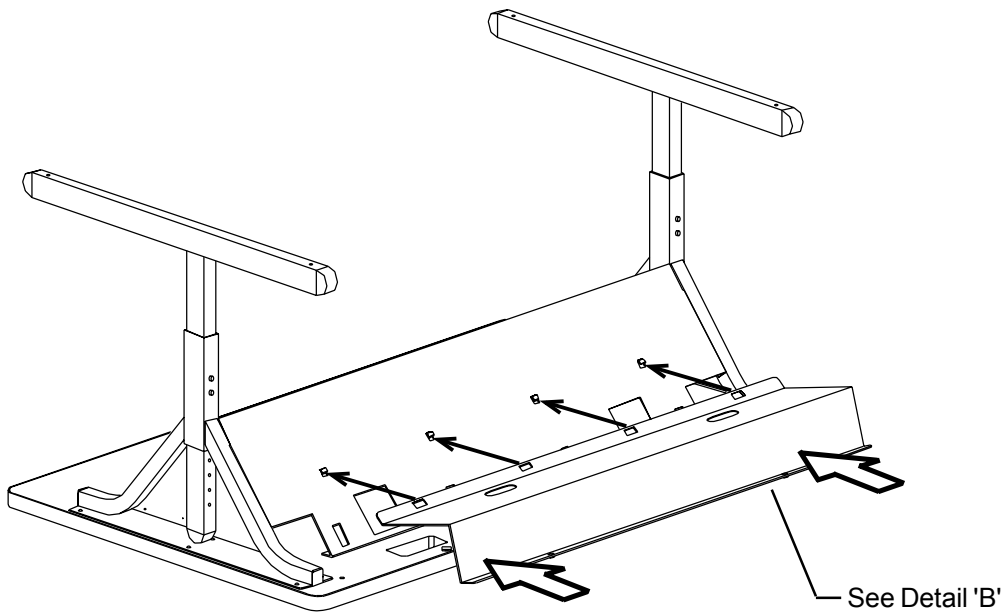

Step 4

Insert screws (FF) into the cord bin flange with the embossed hole(s) . Then slide on the nylon washer (HH) to capture the screw (as shown in Detail 'B'). Attach the cord bin to the modesty panel by hooking the rectangular slots onto the modesty panel hooks. Pivot the cord bin down to the table top to align the screw(s) on the embossed flange and tighten.

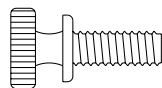

FF



HH

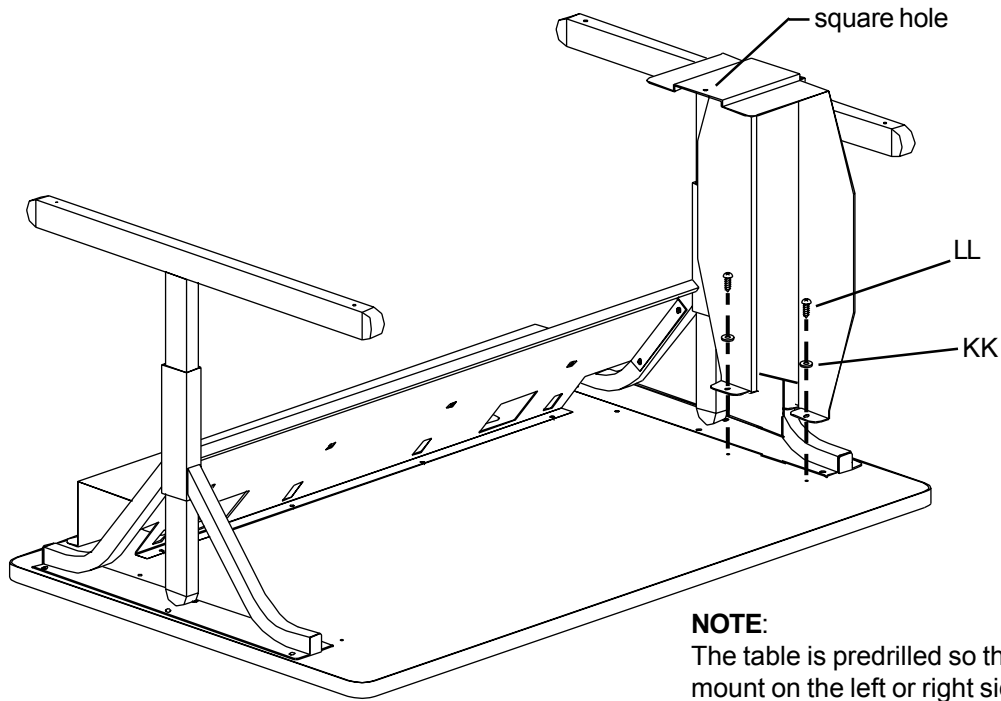

NOTE:
The table is predrilled so the first cpu bracket can mount on the left or right side of your table

Step 5

Attach the CPU bracket with the square hole located on the bottom flange first. Install with washers (KK) and screws (LL) as shown.

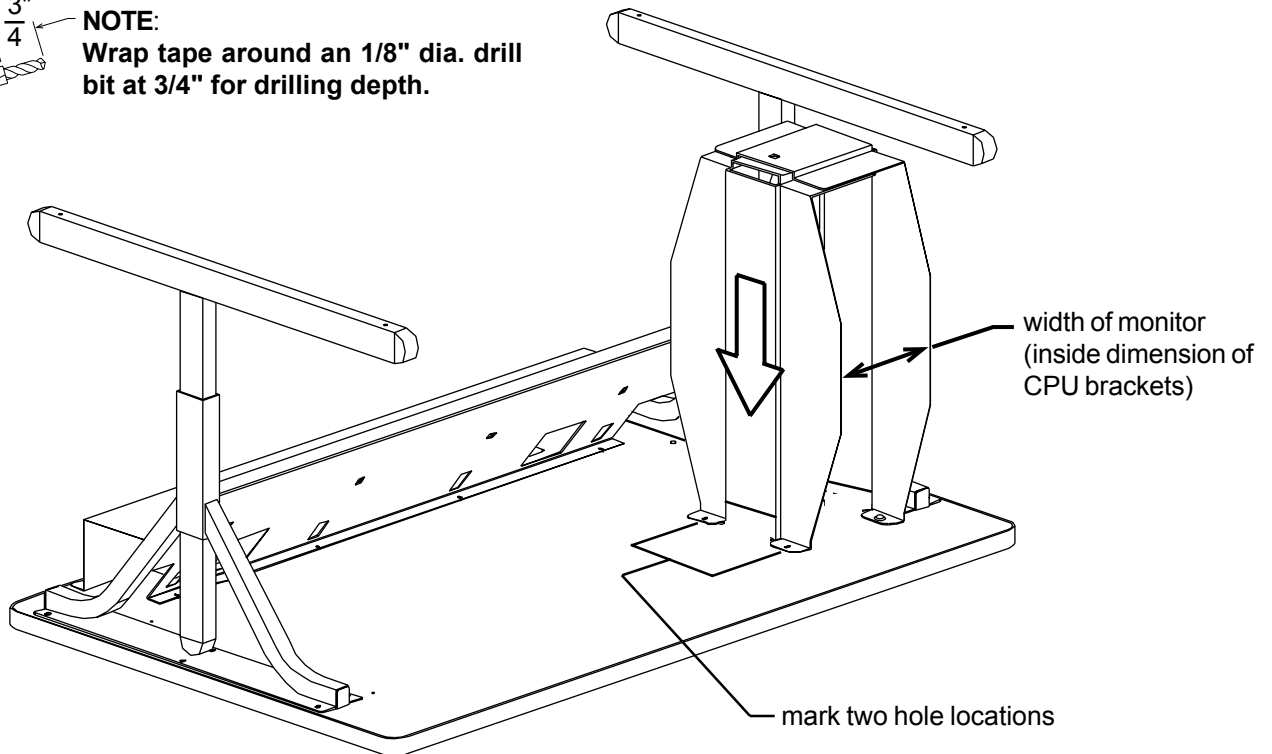
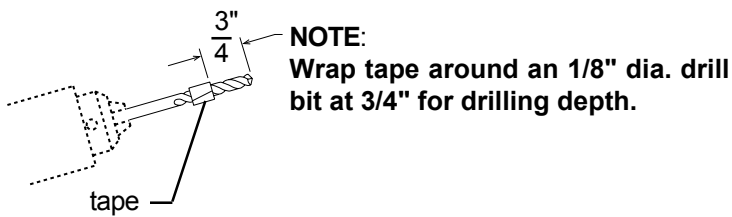
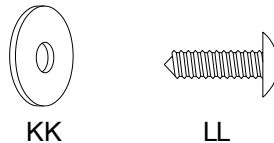

Step 6

Determine the overall width of your cpu. Place the other CPU bracket (with the slotted hole located at the bottom) over the mounted CPU bracket as shown. Adjust the space between the two brackets by sliding the bracket side to side to equal your cpu width. **MAKE SURE THAT THE BRACKETS ARE PARALLEL.** Using the CPU bracket as a template, mark the two hole locations for drilling pilot holes. Carefully drill an 1/8" dia. pilot holes 3/4" deep (see note above). Install the second bracket with washers (KK) and screws (LL).

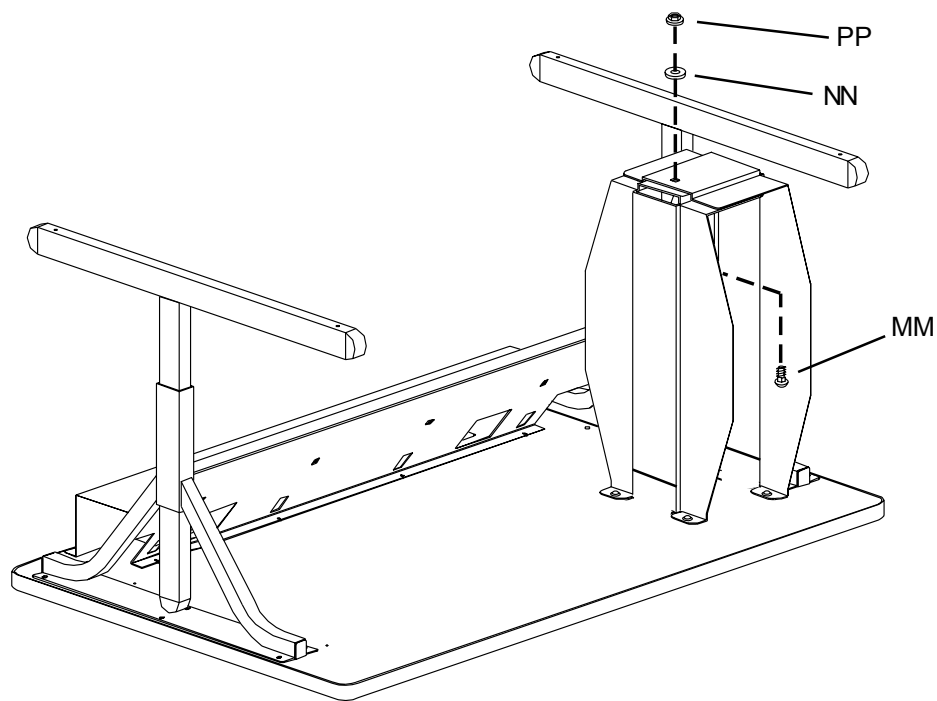

Step 7

Install carriage bolt (MM) to the inside flange with washer (NN) and nut (PP) on the outside flange as shown. Repeat steps 5, 6 & 7 for 35XTC25 to install additional holder.

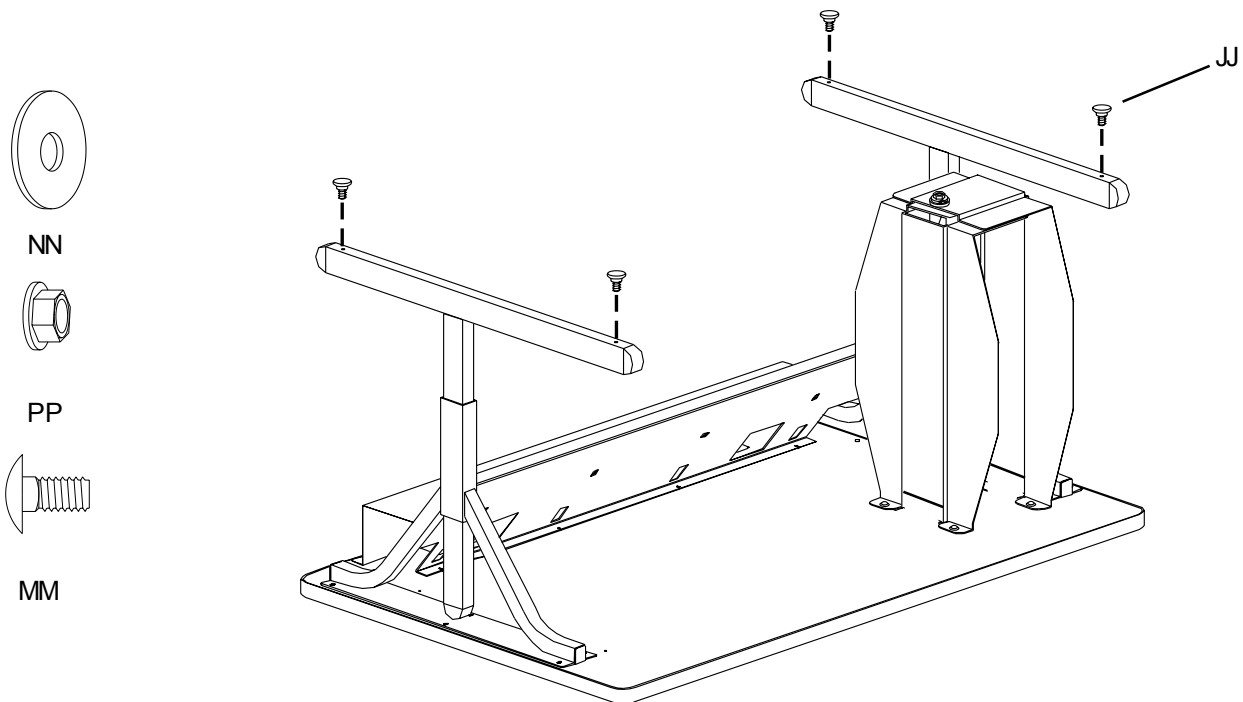

Step 8

Install glides (JJ) into leg bottom as shown. Carefully turn over the table and place into position and adjust glides if necessary.

Bretford
 11000 Seymour Avenue
 Franklin Park, IL 60131
 TEL: 847.678.2545
 800.521.9614
 FAX: 847.678.0852
 800.343.1779

Bretford Manufacturin Ltd.
 2 Etigate
 110 Windsor Road, Slough
 Berkshire SL1 2JA England
 TEL: 01753 539955
 FAX: 01753 539478