

BBC48 BBC54 Wide-Body TV Cabinet Cart Assembly Instructions

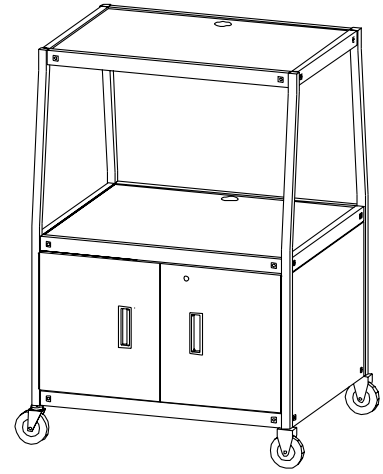

PARTS LIST

Qty	Part#	Description
1	010-1891	Top Shelf
2	010-1908	Side Panels
1	010-1909	Rear Panel
1	010-1910	Bottom Shelf
1	022-1414	Middle Shelf w/ Door Stop
1	022-1415	Right Door Assembly
1	022-1416	Left Door Assembly
1	022-1498	Right Front Leg (BBC48)
1	022-1499	Left Front Leg (BBC48)
1	022-1500	Right Rear Leg (BBC48)
1	022-1501	Left Rear Leg (BBC48)
	022-1410	Right Front Leg (BBC54)
	022-1411	Left Front Leg (BBC54)
	022-1412	Right Rear Leg (BBC54)
	022-1413	Left Rear Leg (BBC54)
2	015-0002	4" Casters w/o Lock
2	015-0003	4" Casters w/ Lock
	OR	
2	015-0017	5" Casters w/o Lock
2	015-0018	5" Casters w/ Lock

HARDWARE LIST

Ref	Qty	Part#	Description
AA	24	030-0300	5/8" Square Head Bolts
BB	24	030-0002	5/16"-18 Serrated Nuts
CC	2	030-0023	#6-32 x 3/8" Machine Screws
DD	2	030-0024	#6-32 Hex Nuts
EE	4	030-0259	#10 x 1/2" Phillips Screws
FF	4	030-0325	1/4-20 x 1/2" Combo Screws
	1	010-1188	Bottom Door Stop
	2	012-0286	Plastic Handles
	1	010-1106	Hex Wrench

TOOLS REQUIRED

- Hex Wrench (Provided)
- Phillips Screwdriver
- Rubber Mallet (Optional)

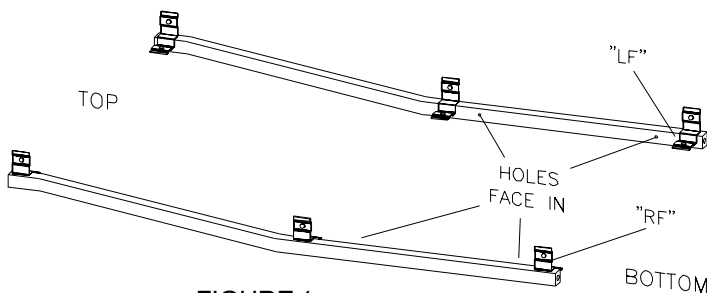

FIGURE 1

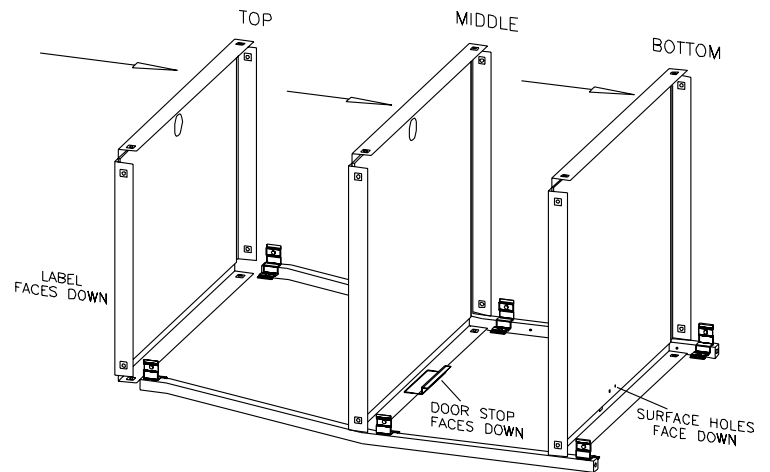
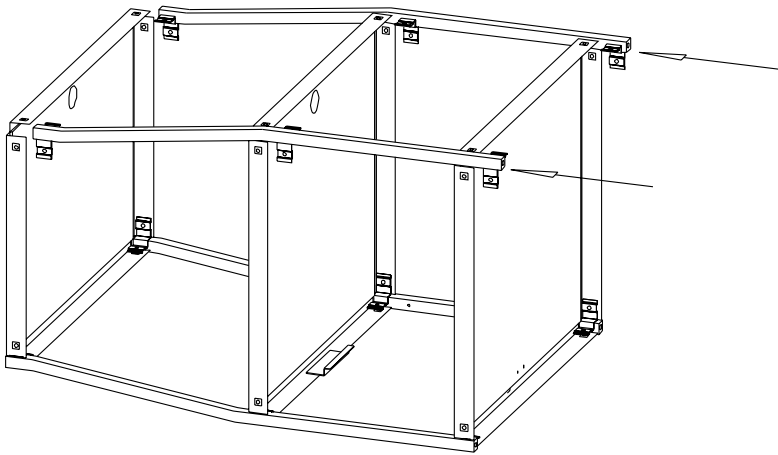

FIGURE 2

STEP 1

Position the front legs (stamped "LF" and "RF") with the brackets facing up and in as shown in **FIGURE 1**. Slide each shelf onto the legs making sure the brackets are inside of the shelves as shown in **FIGURE 2**.



STEP 2

Slide the 2 remaining legs onto the shelves as shown. Make sure the brackets are inside the shelves.

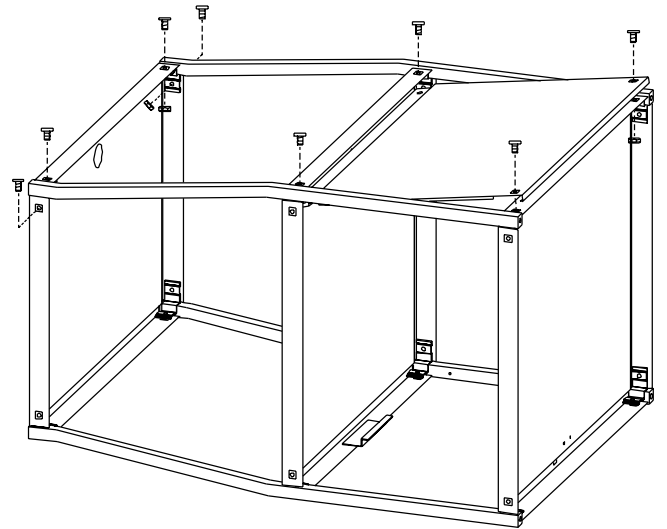

STEP 3

LOOSELY attach the top shelf at each accessible corner with bolts (AA) and nuts (BB). Then slide the back panel between the middle and bottom shelf so that the top flange is behind the leg brackets and the bottom hooks onto the bottom shelf. **LOOSELY** attach in the 4 corners as shown.

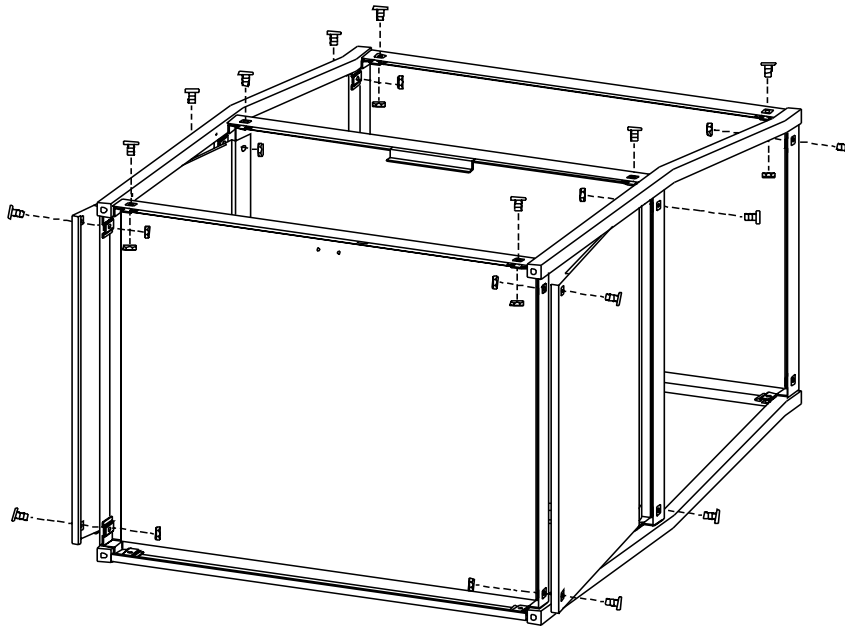
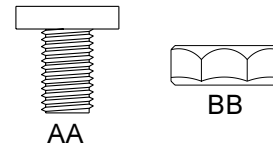

STEP 4

CAREFULLY turn the unit on its back. Finish fastening the top shelf to legs. Then attach each side panel in the same manner as described in STEP 3 using bolts (AA) and nuts (BB) as shown.

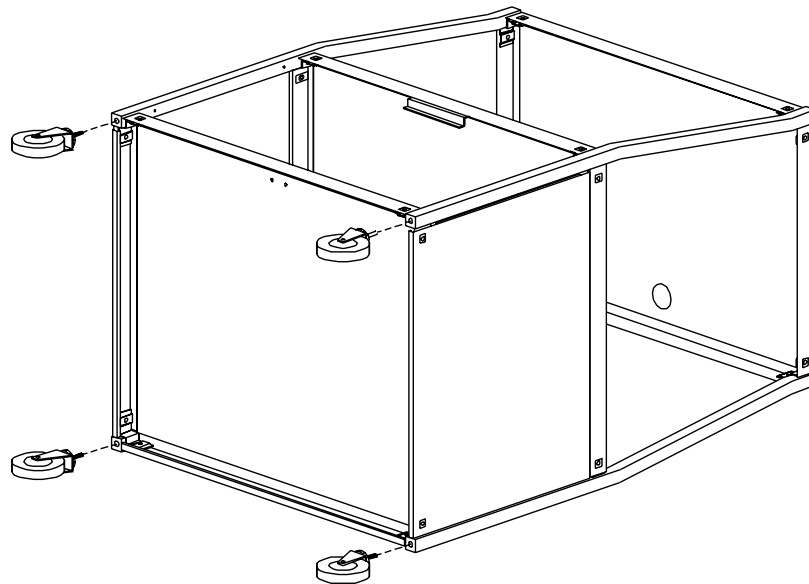

STEP 5

Push casters into each the sockets in each leg. To ensure casters are secure in sockets, a rubber mallet may be used to tap casters in place.

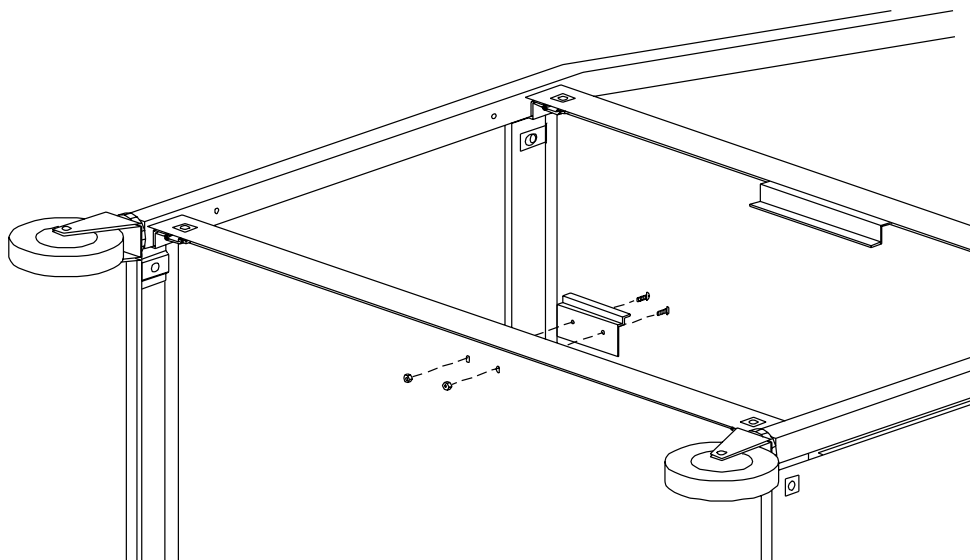

STEP 6

Attach door stop to bottom shelf using screws (CC) and nuts (DD). Stand unit upright and **TIGHTEN ALL SHELF HARDWARE**.

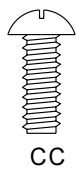

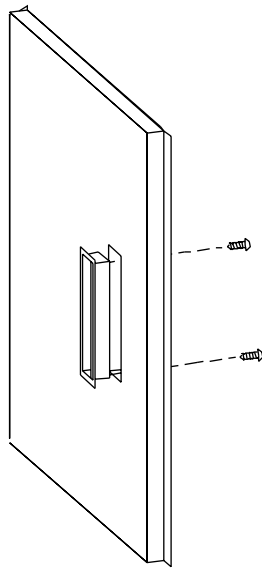

STEP 7

Attach the door handles using screws (EE).

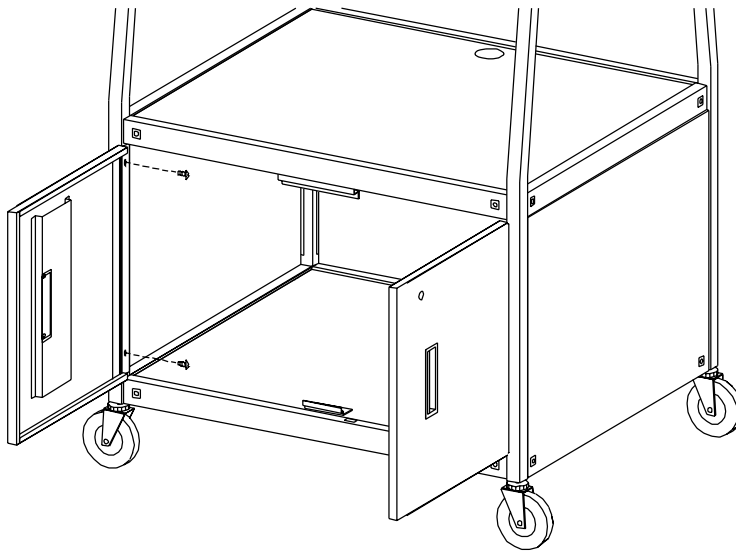
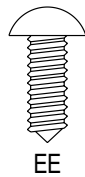

STEP 8

Attach the doors (right one has lock) between the middle and bottom shelves with screws (FF) as shown. **NOTE:** Adjustments to the door stop may need to be done.

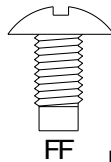

Bretford
11000 Seymour Avenue
Franklin Park, IL 60131
TEL: 847.678.2545
800.521.9614
FAX: 847.678.0852
800.343.1779

Bretford Ltd.
Technology House
7 Lake End Court, Taplow
Bucks SL6 0JQ England
TEL: 01628 603558
FAX: 01628 604923

www.bretford.com

Part#031-1116
Rev. 10.16.96 CH