

3511

Adjustable Corner Table Assembly Instructions

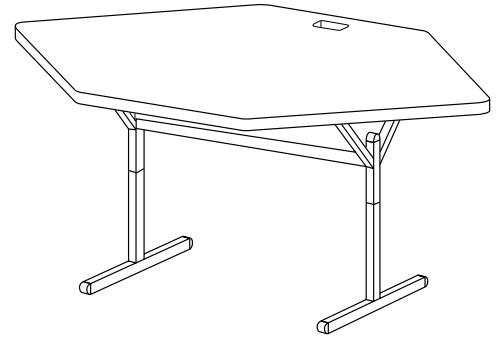

PARTS LIST

Qty	Part#	Description
1	SA1656	Wood Top
2	022-1593	Lower Leg Assembly
1	022-1589	Right Upper Leg Assembly
1	022-1590	Left Upper Leg Assembly
1	010-2321	Modesty Panel
1	010-2323	Cord Bin

HARDWARE LIST

Ref.	Qty	Part#	Description
AA	12	030-0402	10-32 x 5/8" Combo Screws
BB	4	030-0396	3/8-16 x 1/2" Set Screws
CC	1	030-0397	Allen Wrench
DD	4	030-0325	1/4-20 1/2" Combo Truss Screws
EE	6	030-0168	#8 x 1/2" Wood Screws
FF	2	030-0433	10-32 x 1/2" Knurled Screws
HH	2	030-0465	Retaining Washers
JJ	4	015-0045	Glides
KK	12	030-0240	1/4" External Lockwashers

TOOLS REQUIRED

- Phillips Screwdriver
- Rubber Mallet
- Allen Wrench (provided)

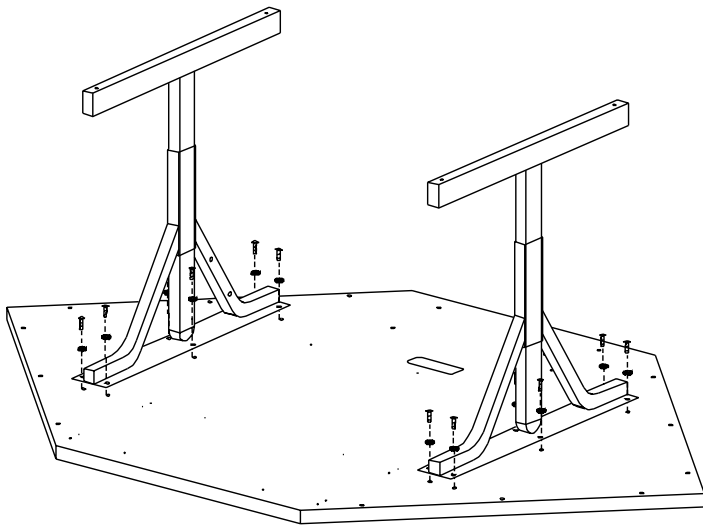

FRONT EDGE

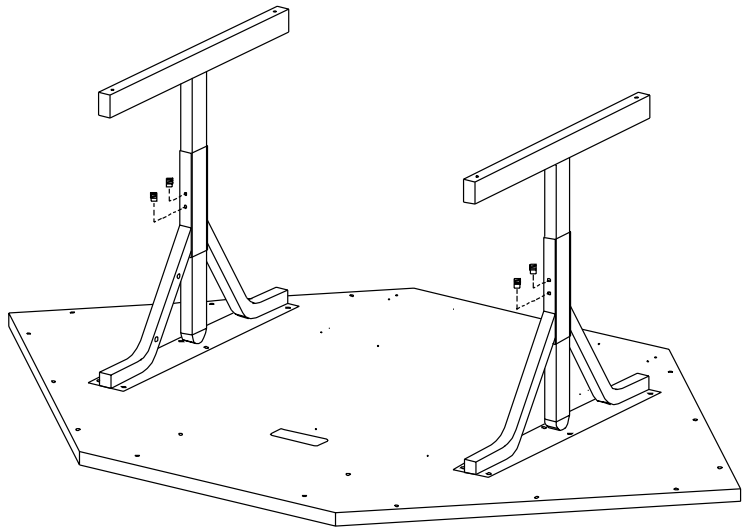

BACK EDGE

STEP 1

Lay wood top on a carpeted surface with holes facing upward. Position the legs onto top with holes facing in and toward back as shown. **LOOSELY** attach with screws (AA) and washers (KK).

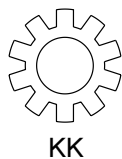
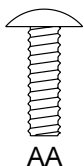

STEP 2

Set desired height and insert set screws (BB) into legs and tighten with Allen wrench (provided).

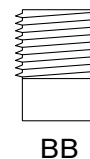

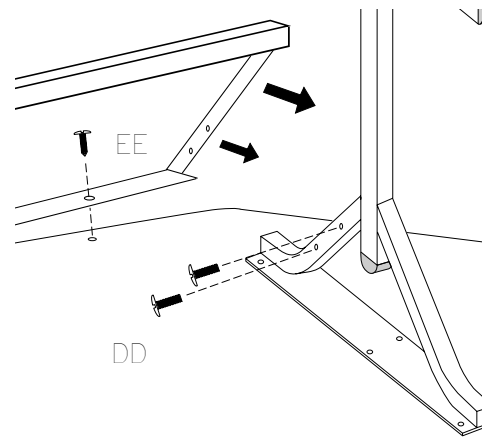
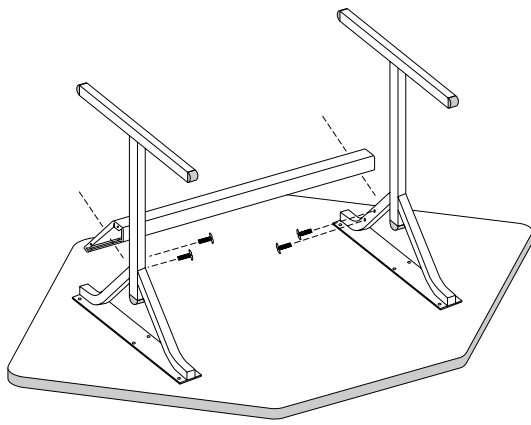

STEP 3

Slide in modesty panel. Tightly secure modesty panel to legs with screws (DD). Attach to wood top using screws (EE). **TIGHTEN ALL HARDWARE.** NOTE: Any "C" frames for shelves must be assembled prior to attaching the modesty panel.

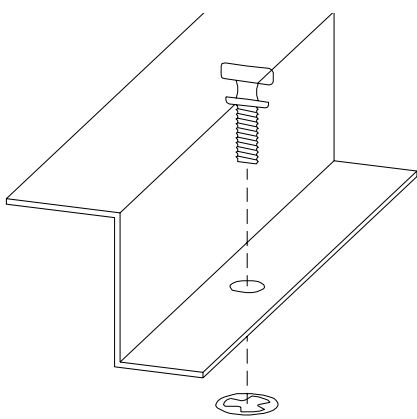
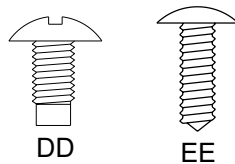

FIG. 1

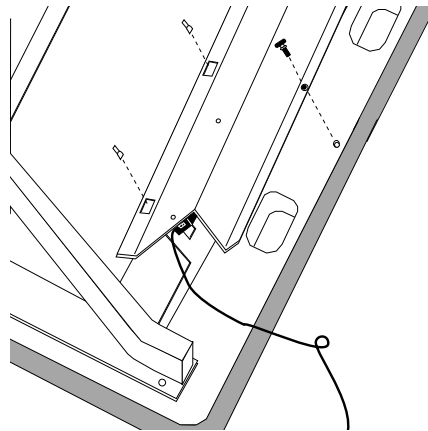
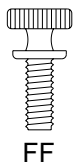

FIG. 2

STEP 4

Insert screws (FF) into the holes in cord bin. Then slide on washer (HH) as shown in **Fig. 1**. Attach cord bin to hooks on the back of the modesty. Secure to bottom of wood top as shown in **Fig. 2**.



FF



HH

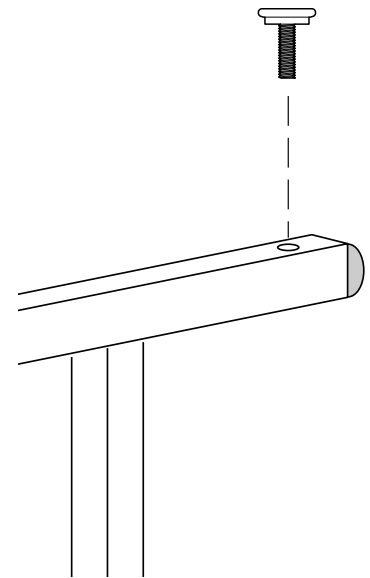

STEP 5

Screw glides (JJ) into the bottom of the legs. Turn unit over, position and adjust glides to floor.

Bretford
11000 Seymour Avenue
Franklin Park, IL 60131
TEL: 847.678.2545
800.521.9614
FAX: 847.678.0852
800.343.1779

Bretford Ltd.
Technology House
7 Lake End Court, Taplow
Bucks SL6 0JQ England
TEL: 01628 603558
FAX: 01628 604923