

ECILS15 / ECILS15FF  
 DATA PROJECTOR CART  
 Assembly Instructions

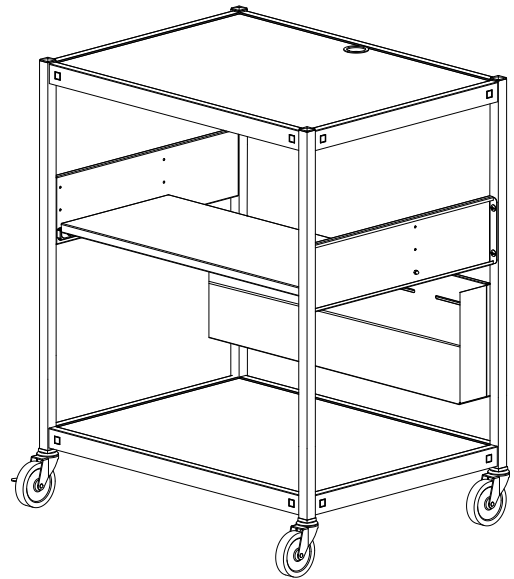

**PARTS LIST**

Qty	Part#	Description	Ref
1	022-2006	Top Shelf w/ grommet hole	AA
1	010-4513	Slide Out Shelf	BB
1	010-3953	Bottom Shelf	CC
2	010-4506	Shelf Support Brackets	DD
1	022-2009	Right Front Leg	EE
1	022-2008	Left Front Leg	FF
1	022-2011	Right Rear Leg	GG
1	022-2010	Left Rear Leg	HH
1	022-2309	Wire Tray	
2	015-0002	4" Casters w/o Lock	
2	015-0003	4" Casters w/ Lock	
1	030-1191	14" Full Extension Slide	
1	ECF6	Electrical Unit - ECILS15FF ONLY	

**HARDWARE LIST**

Qty	Part#	Description
16	030-0300-21S	5/8" Square Head Bolts
16	030-0002	5/16-18 Hex Serrated Nuts
12	030-0304	1/4-20 x 5/8" Combo Screws
8	030-1228	8-32 x 1/4" Combo Truss Hd Screws
4	030-1203	#8-32 Acorn Nuts
2	020016	#6-32 Hex Nuts - ECILS15FF ONLY
2	020017	#6-32 x 1/4" Screws - ECILS15FF ONLY
4	02236	8-32 Hex Flange Nuts
1	010-1106	Hex Wrench

**TOOLS REQUIRED**

- Hex Wrench (Provided)
- Phillips Screwdriver
- Rubber Mallet

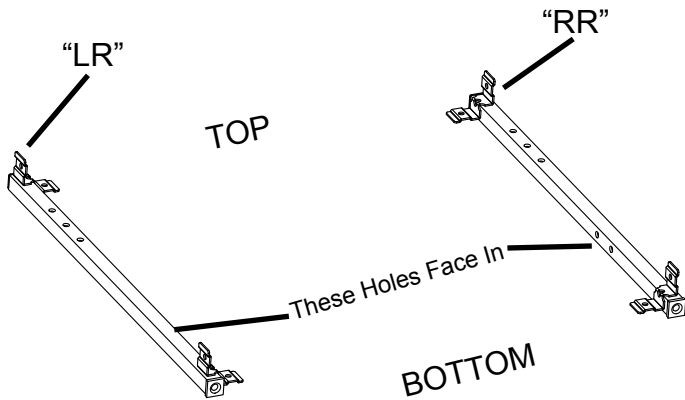

**FIGURE 1**

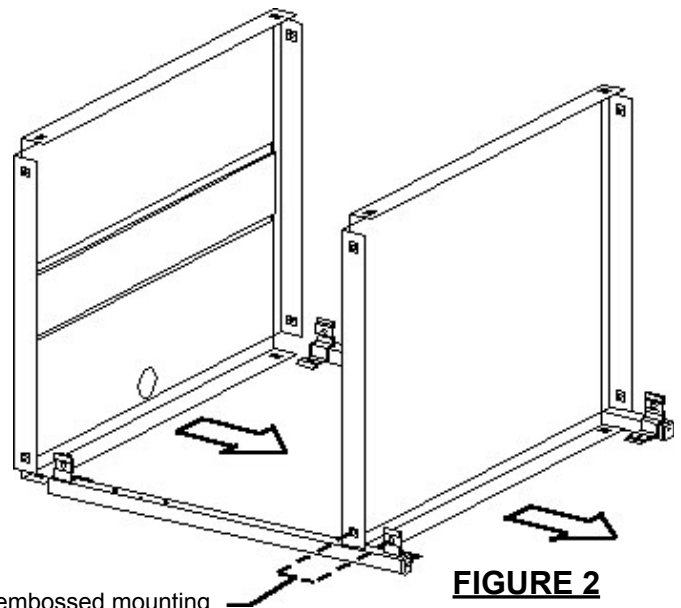

**FIGURE 2**

Align shelf embossed mounting hole with leg mounting bracket. 2 corners each shelf.

**STEP 1**

Lay the rear legs on a carpeted surface (they are stamped "LR" and "RR") with the three top holes facing up and the bracket facing up as shown in Figure 1. Slide the top shelf (with hole at rear) and bottom shelf (with 4 square holes toward front) onto the legs so that the brackets are inside the shelves (see Figure 2).

Align shelf embossed mounting hole with leg mounting bracket. 2 corners each shelf.

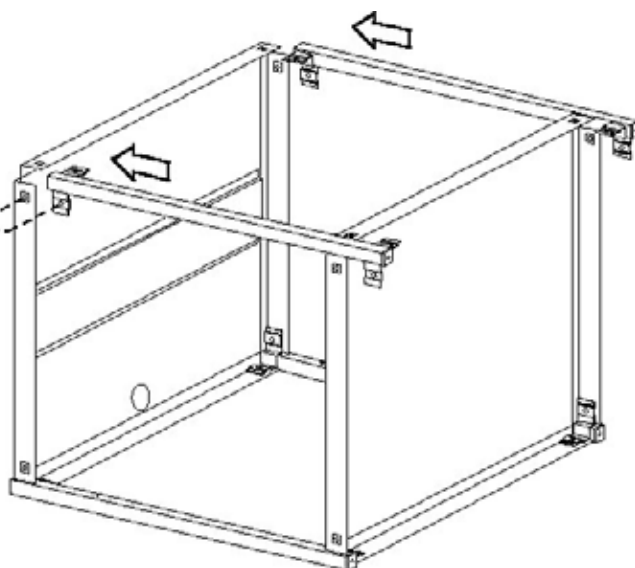

### STEP 2

Slide the front legs (they are stamped "LF" and "RF") onto the shelves so that the brackets are inside the shelves.

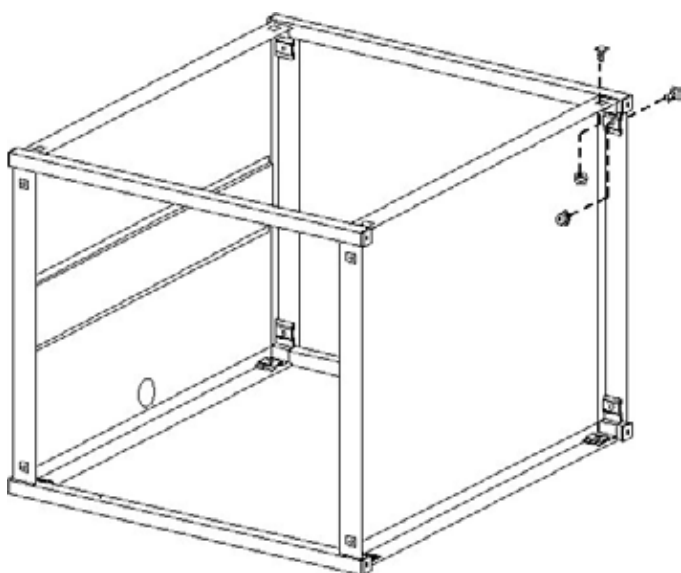

### STEP 3

Secure shelves and legs together with bolts (AA) and nuts (BB) in each corner as shown.

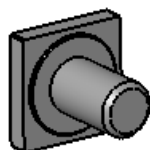

AA



BB

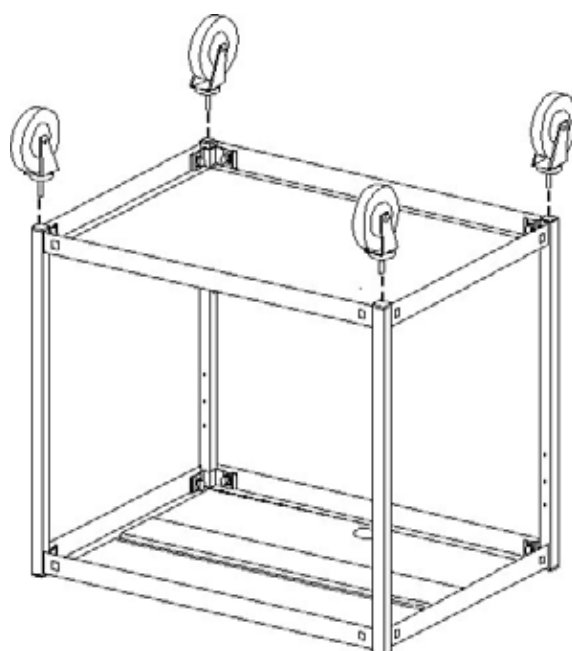

### STEP 4

Insert each caster into the bottom of each leg. If caster does not insert easily, use a rubber mallet to tap caster in place. Once casters are **SECURELY** in place, stand unit upright.

## SHELF SUPPORT BRACKET

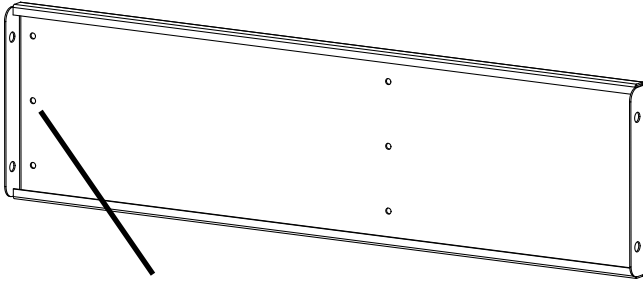

THESE HOLES MUST FACE FRONT  
EDGE OF CART. (SIDE OPPOSITE  
THE GROMMET)

### DETAIL 'A'

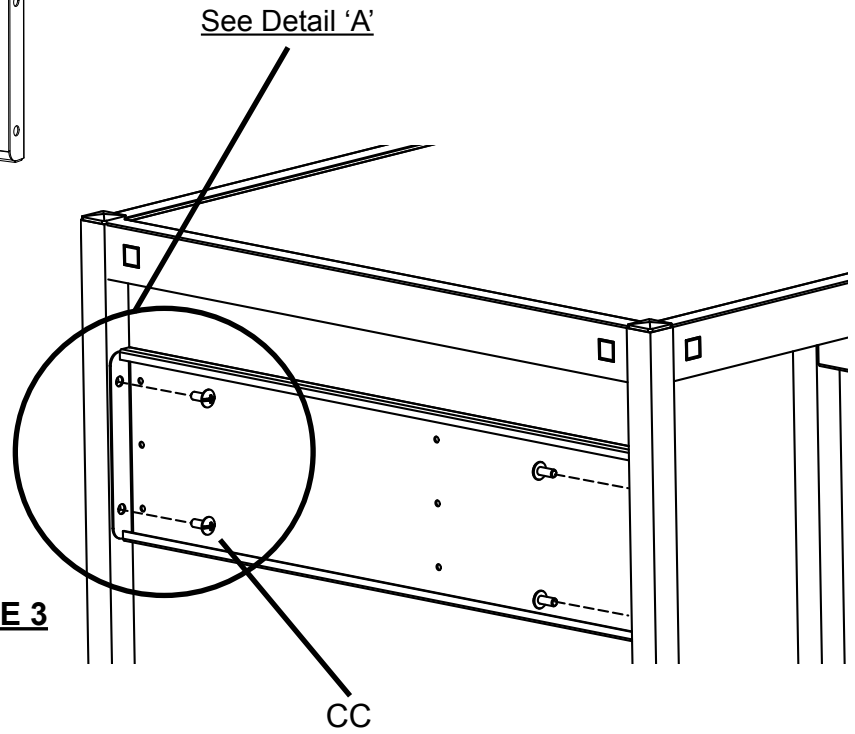

FIGURE 3

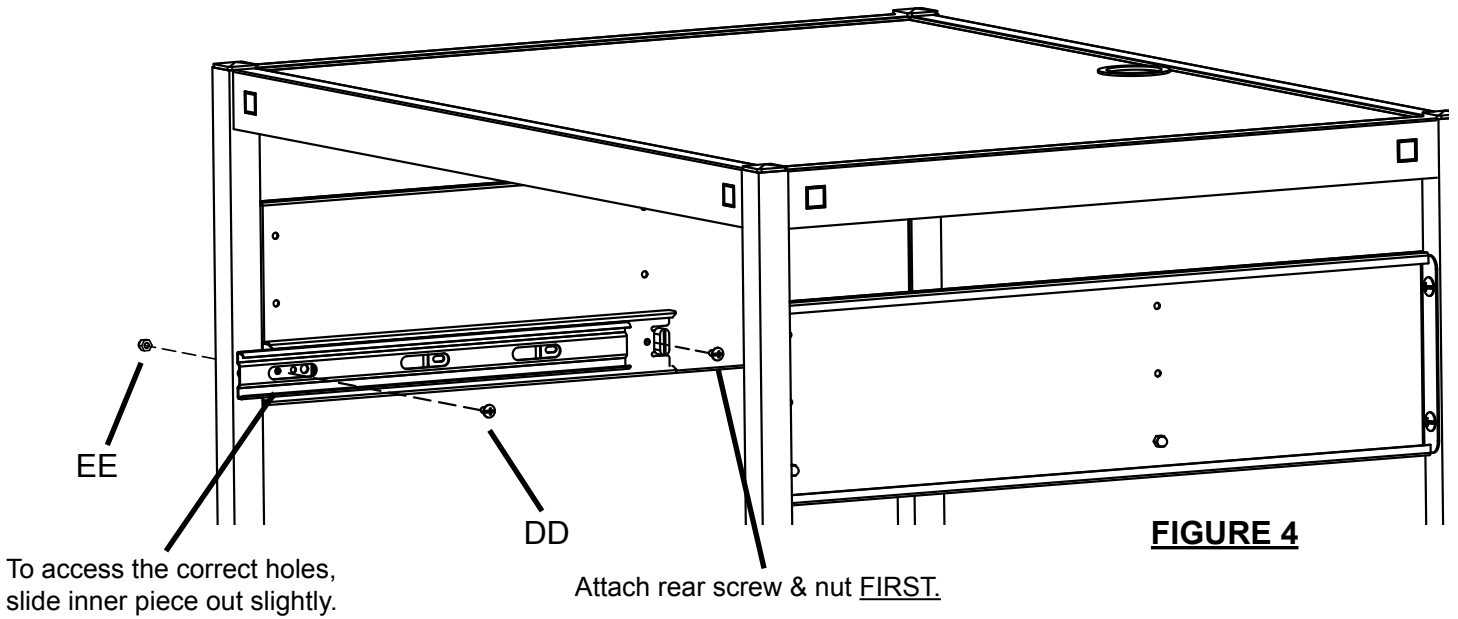

FIGURE 4

To access the correct holes,  
slide inner piece out slightly.

Attach rear screw & nut FIRST.

### STEP 5

Attach shelf support brackets to upper portion of rear legs with screws (CC) as shown in **FIGURE 3**. Refer to Detail 'A' for correct position of bracket. Then separate each slide and attach the outer section to the inside of each shelf support bracket with screws (DD) and nuts (EE) as shown in **FIGURE 4**.

**NOTE:** Attach rear screw and nut first.



CC



DD



EE

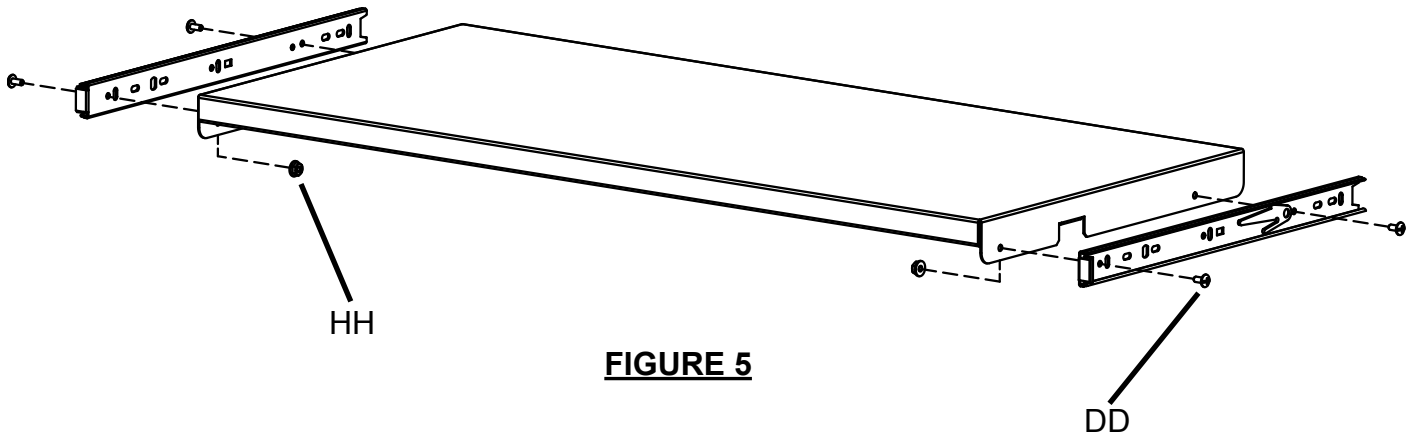

**FIGURE 5**

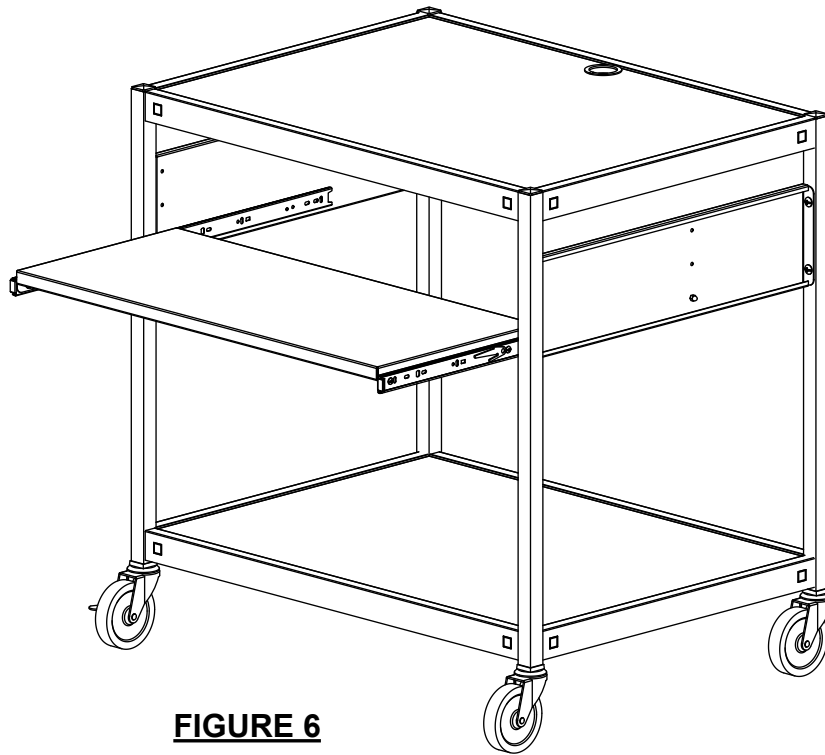

**FIGURE 6**

**STEP 6**

Attach the remaining slide pieces to the pull out shelf with screws (HH) and nuts (JJ) as shown in **FIGURE 5**. Then slide shelf into cart as shown in **FIGURE 6**.



HH

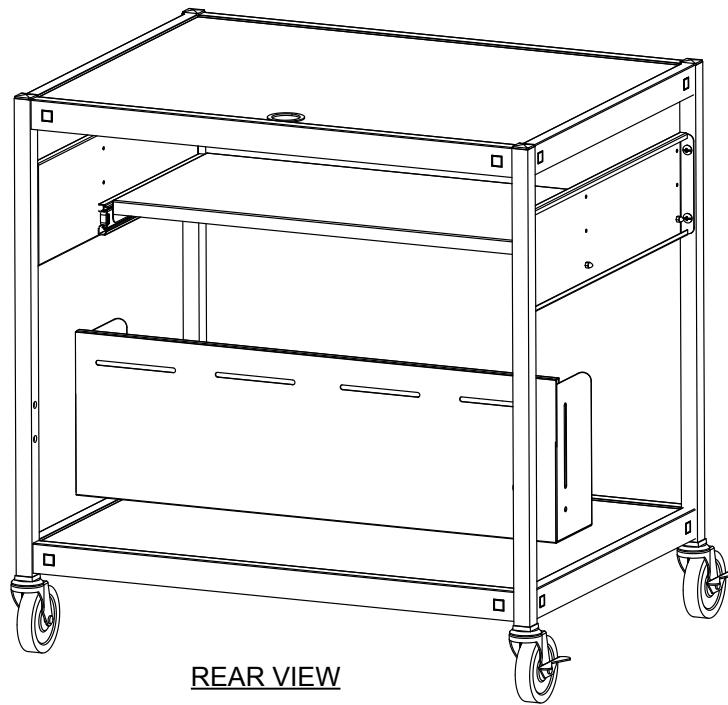

REAR VIEW

**STEP 7**

Slide the cord bin between the rear legs and align slotted holes of the cord bin sides with the (2) mounting holes of the legs. Position the cord bin per Detail 'B' to obtain desired height and install four screws (CC).

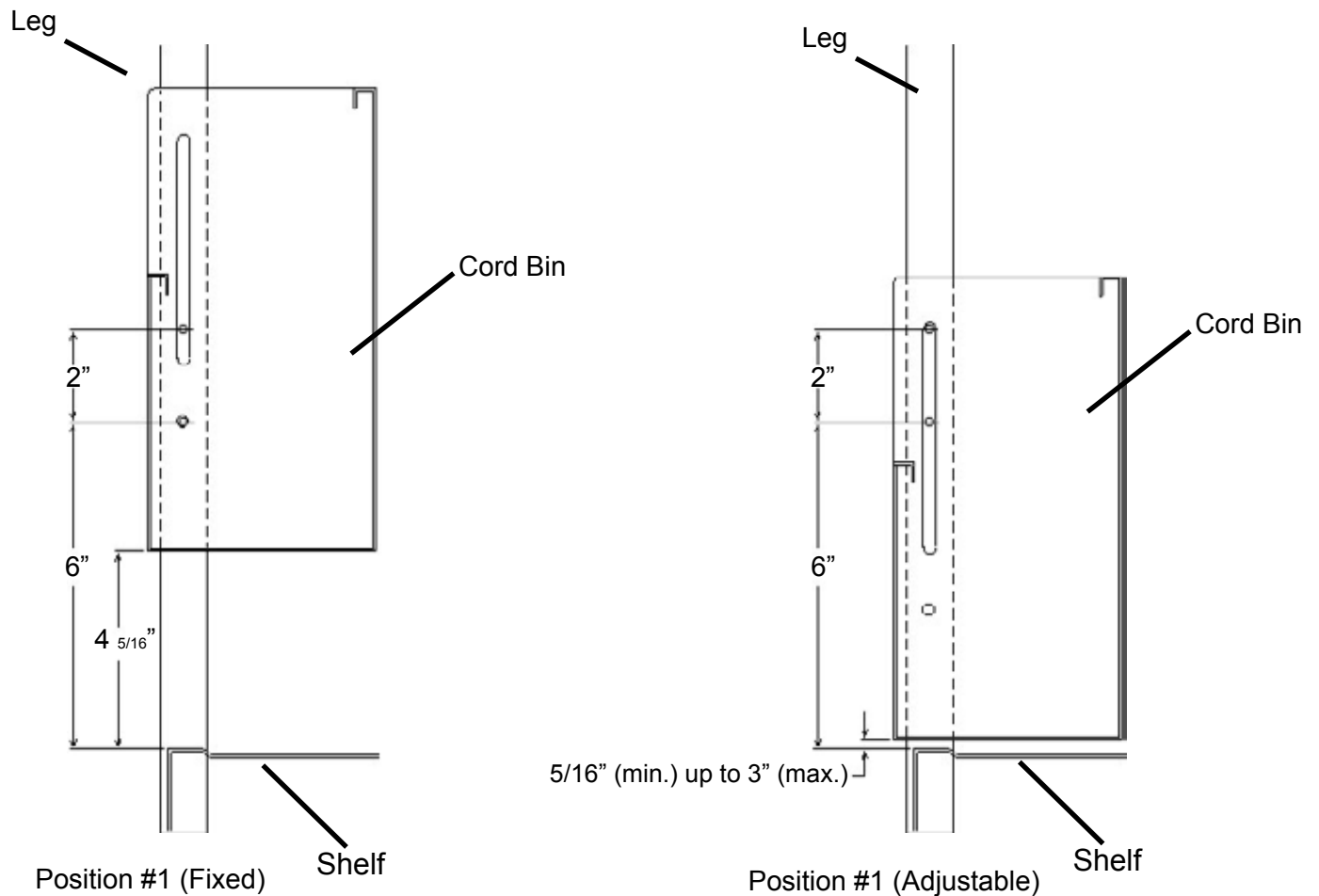

**Detail 'B'**

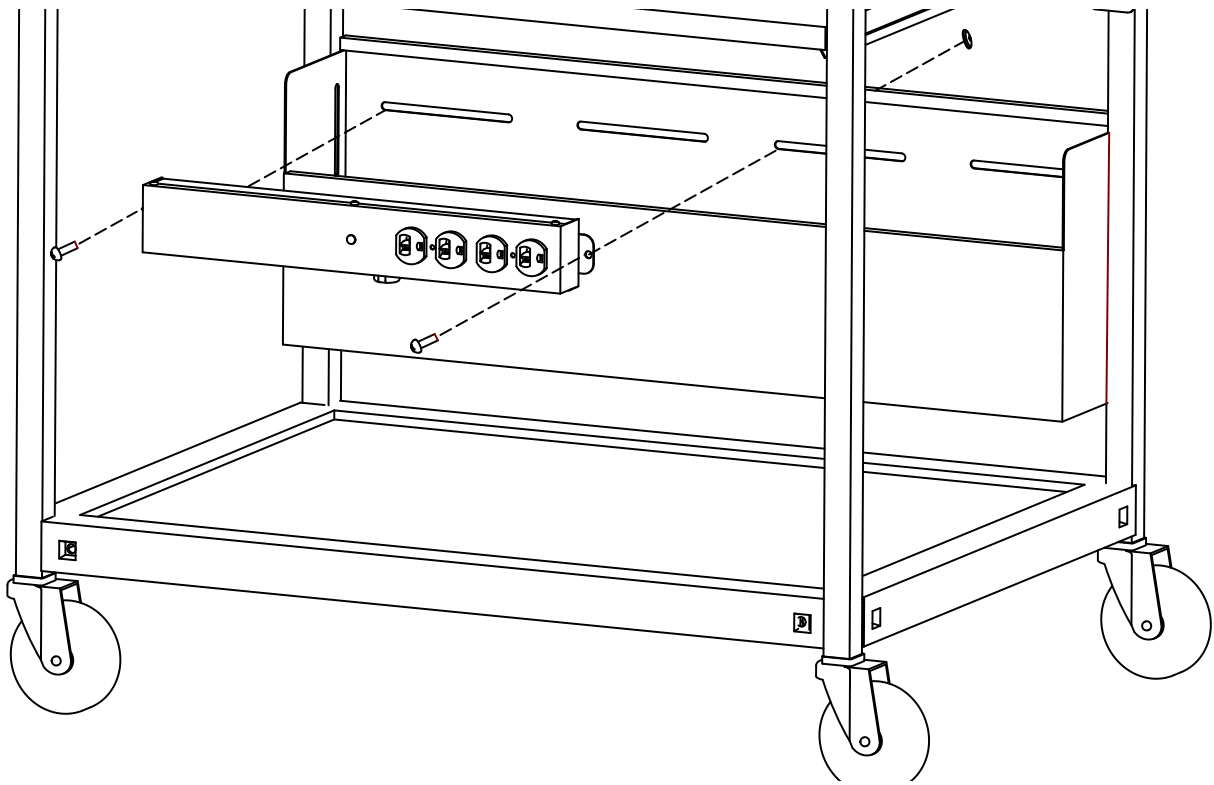

### STEP 8

Align the CFPS electrical unit with the slots in the inside of the cord bin.  
Secure the unit in place with screws (FF) and nuts (GG) as shown.



FF



GG

Bretford  
11000 Seymour Avenue  
Franklin Park, IL 60131  
TEL: 847.678.2545  
800.521.9614  
FAX: 847.678.0852  
800.343.1779

Bretford Ltd.  
2 Etongate  
110 Windsor Road, Slough  
Berkshire SL1 2JA England  
TEL: 011 44 17 5353 9955  
FAX: 011 44 17 5353 9478

[www.bretford.com](http://www.bretford.com)