

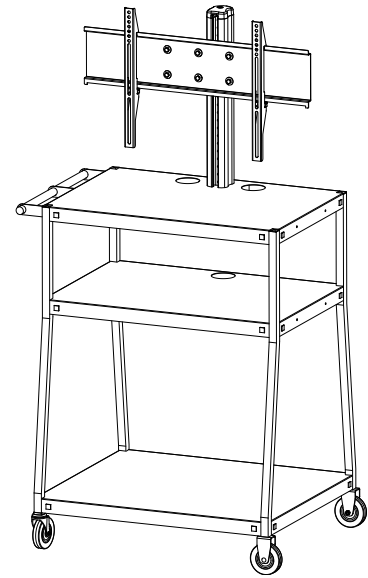

**BRETFORD**

**FPBBUL32**

**FLAT PANEL WIDE BODY  
CART W/O CABINET**



**WARNING:** This cart is intended to support TV monitors up to and including 60 lbs. The use of a TV monitor weighing more than that may result in instability causing possible injury.

**PARTS LIST**

Qty	Part#	Description	Ref	Qty
1	022-1553	Right Front Leg Assembly	AA	22
1	022-1529	Left Front Leg Assembly	BB	24
1	022-1554	Right Rear Leg Assembly	CC	2
1	022-1528	Left Rear Leg Assembly	DD	2
1	022-2811	Top Shelf	EE	2
1	010-5110	Middle Shelf	FF	2
1	010-1892	Bottom Shelf	GG	2
1	022-2825	Handle Assembly	HH	1
1	010-5117	22" Pole w/ (2) Locking Tabs 010-5048	II	1
1	010-5653	Nugget	JJ	4
1	010-4958	Box Swivel	KK	4
1	010-4959	Swivel Bracket	LL	10
1	010-4954	Main Support Bar	MM	8
2	010-4953	Hook Bars	NN	10
2	010-4956	Stop Brackets	OO	4
2	015-0002	4" Stem Casters w/o Lock	PP	2
2	015-0079	Black Comet Wheels	QQ	2
1	012-0753	Pole Top Cap	RR	4
1	E UNIT	Electrical Unit (For FPBBUL32-E4BK ONLY)	SS	2
1	ES	Electrical Unit (For FPBBUL32-M4BK ONLY)	TT	1

**HARDWARE LIST**

Part#	Description
030-0300-10T	5/8" Square Head Bolts
030-0002	5/16-18 Hex Serrated Nuts
030-0388	5/16-24 x 1.732" Bolts
030-0389	5/16-24 Lock Nuts
030-1349	5/16-18 x 3/4" Hex Hd Screws
030-0402	10-32 x 5/8" Combo Screws
030-0357	10-32 Serrated Flange Nuts
030-1129	5/8-11 UNC x 1 3/4" Socket Screw
030-1217	1 3/4" Diameter Washer
030-0200	1/4-20 X 1" Hex Hd Machine Screws
030-0240	1/4" External Lockwashers
030-0307	5/16-18 x 5/8" Hex Hd Screws
030-0306	1" x 21/64" x 1/16" Washers
030-0411	5/16-18 Serrated Nuts
030-0713	3/8-16 x 5/8" Button Cap Screws
030-1340	1/4-20 x 2" Hex Hd Bolts
030-0043	#10-1/4" Washers
030-0865	#6 x 1/2" Button Pin-In Hd Screws
030-0354	10-32 x 1 1/2" Button Sockets Screws
012-0761	Plastic Clips
010-1106	Hex Wrench
030-1237	1/2" Allen Wrench
030-1352	1/8" Security Pinn-In Driver Bit
044-2124	Courtesy Monitor Hardware Pack

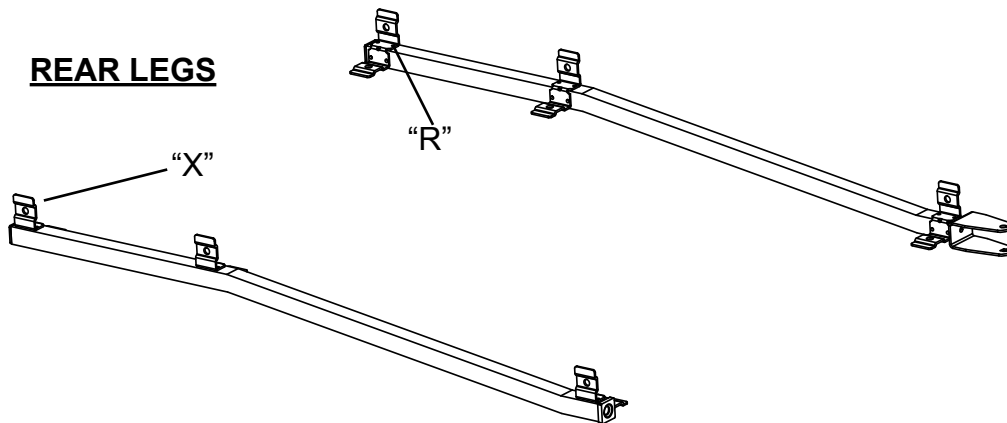

**REAR LEGS**

**STEP 1**

Position the rear legs with brackets facing up and in as shown.

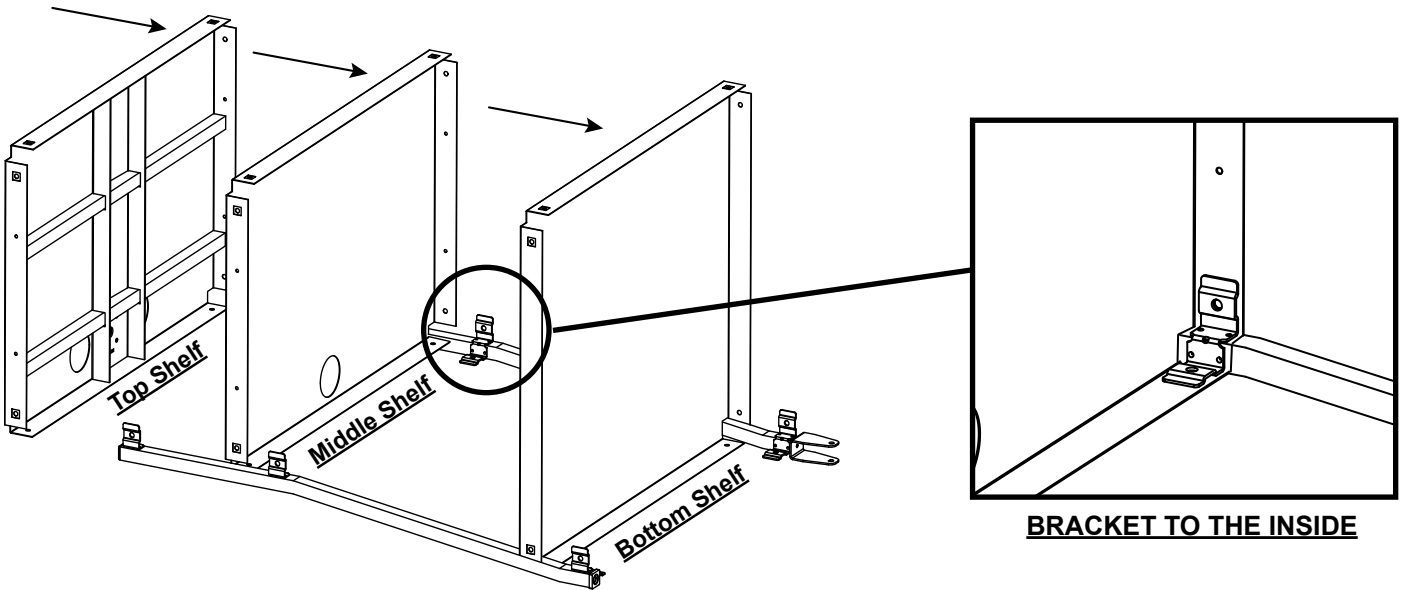

### STEP 2

Slide each shelf onto the legs positioning the reinforced shelf with 2 grommet holes at the top. Make sure the brackets are inside the shelves as shown.

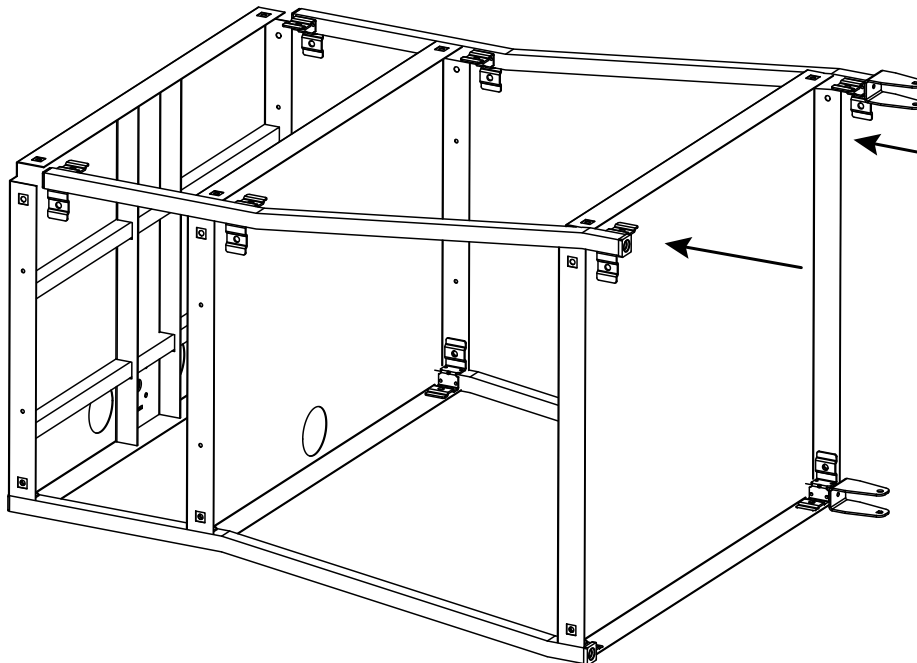

### STEP 3

Slide the 2 remaining legs onto the shelves as shown. Make sure the brackets are inside the shelves.

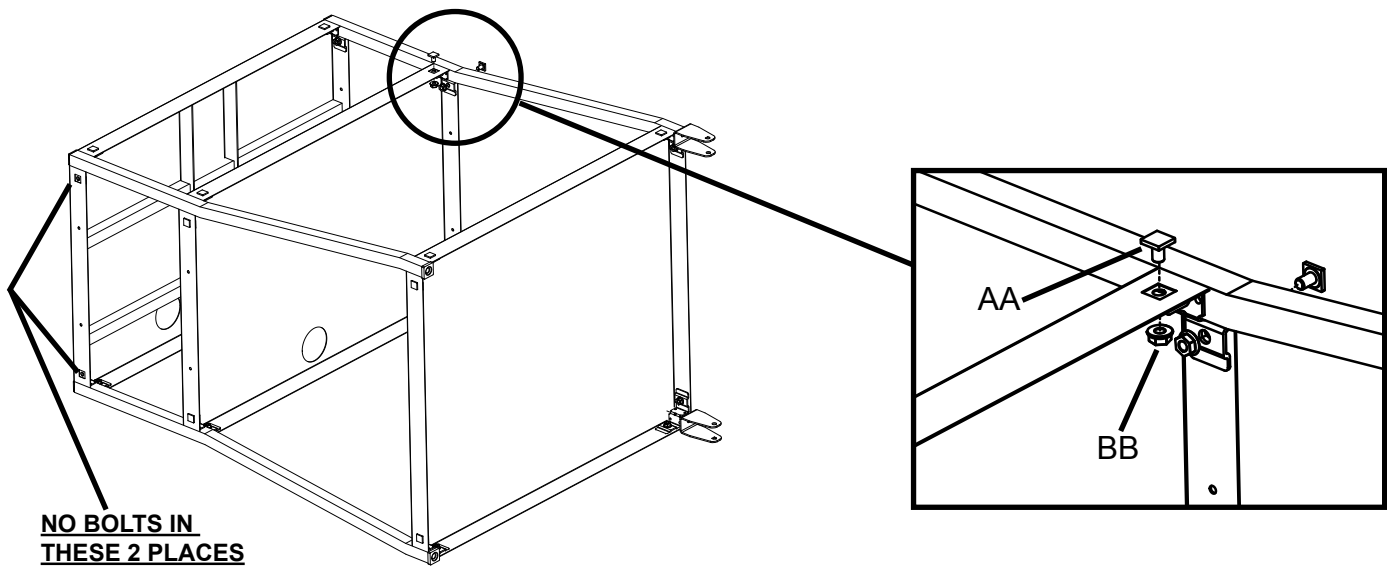

**STEP 4**

Secure each corner of the shelves **EXCEPT for the corners indicated** with bolts (AA) and nuts (BB).

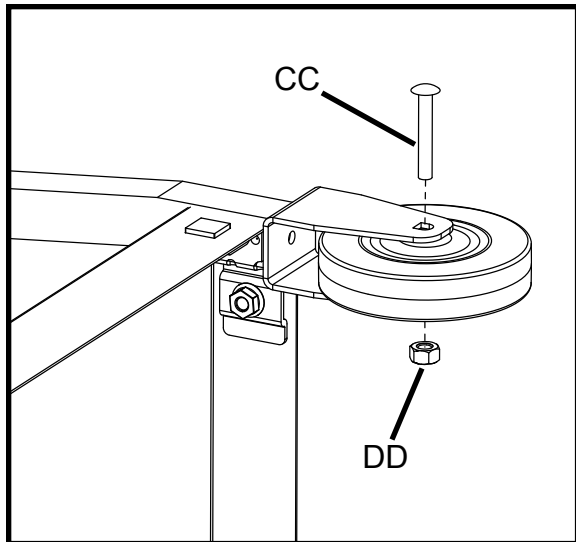
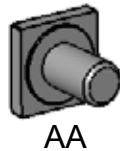

**RIGHT LEGS**  
**FIGURE 1**

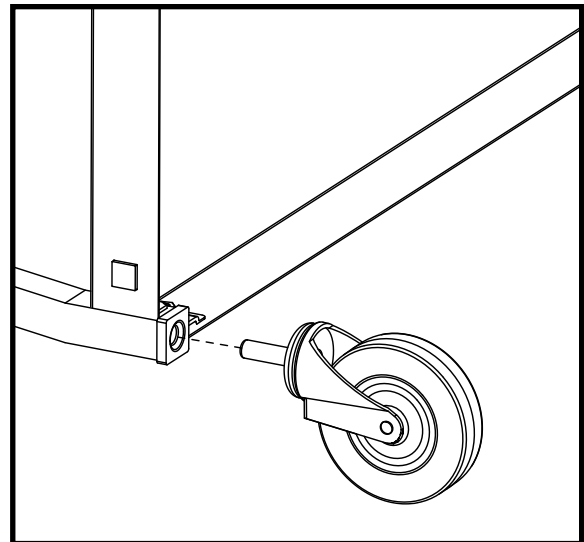

**LEFT LEGS**  
**FIGURE 2**

**STEP 5**

Attach each castor wheel to the right legs with screw (CC) and nut (DD) as shown in **FIGURE 1**. Push each stem castor into the sockets on the left legs as shown in **FIGURE 2**. To ensure castors are securely in the sockets, a rubber mallet may be used to tap them in place. Once both castors are installed, stand unit upright.

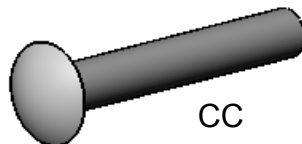

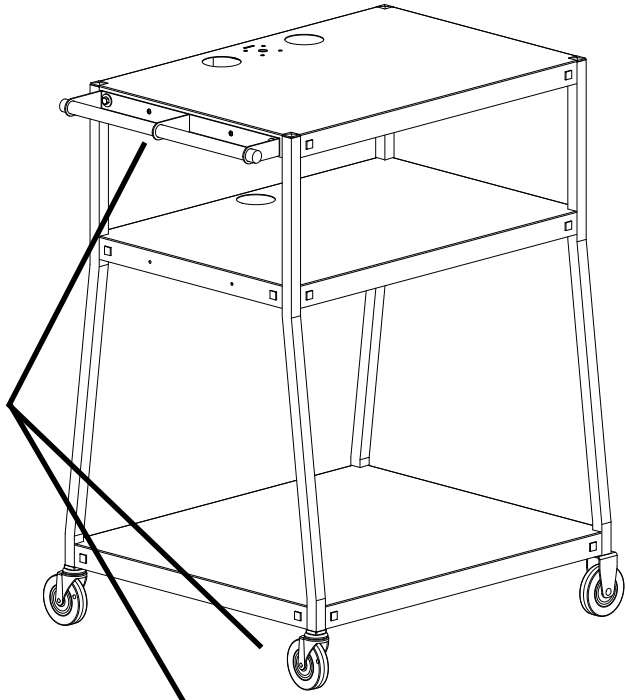

**ATTACH HANDLE ON SIDE OF SWIVEL CASTERS**

**FIGURE 3**

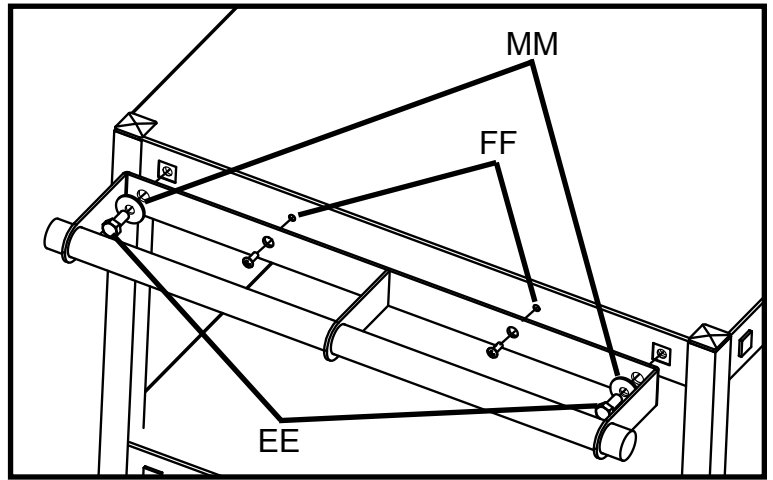

**VIEW FROM ABOVE**

**FIGURE 4**

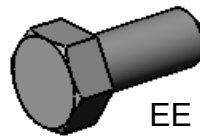

EE

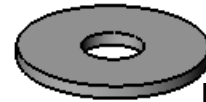

MM



FF

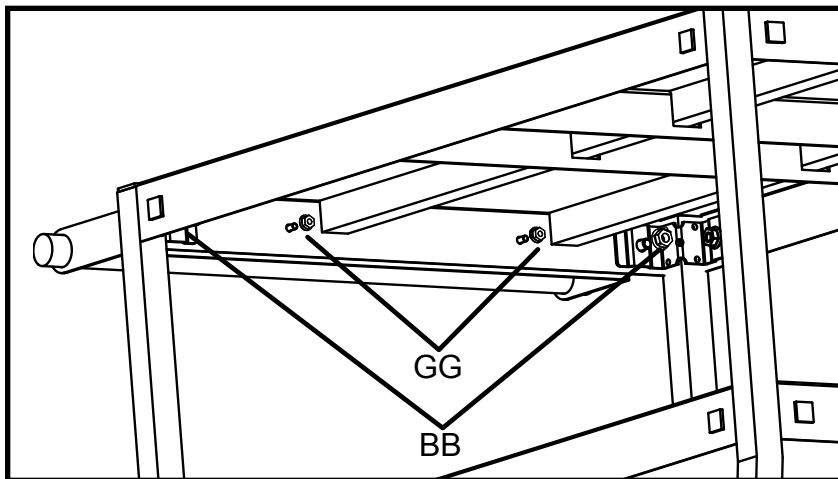

**VIEW FROM UNDERNEATH**

**FIGURE 5**



BB



GG

**STEP 6**

Attach handle assembly to the top shelf as shown in **FIGURE 3**. Make sure the handle is attached on the side of the cart that has the swivel casters. Secure in place with screws (EE) & (FF), washers (MM) and nuts (BB) & (GG) as indicated in **FIGURES 4 & 5**.

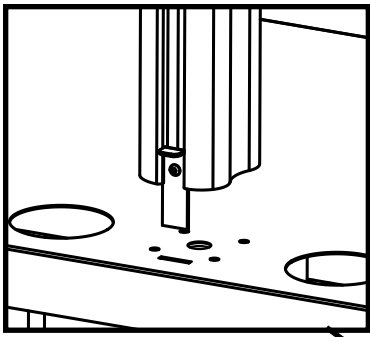

**FIGURE 6**

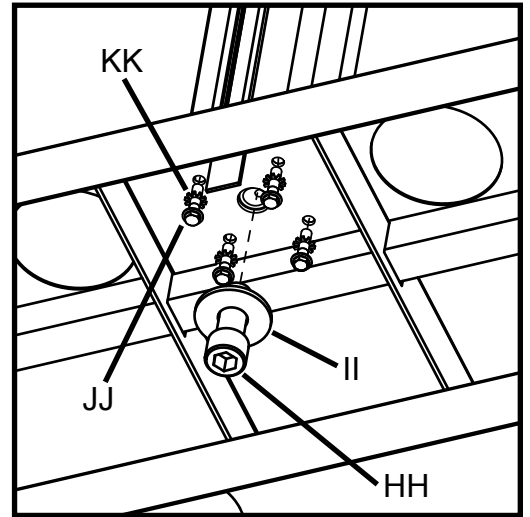
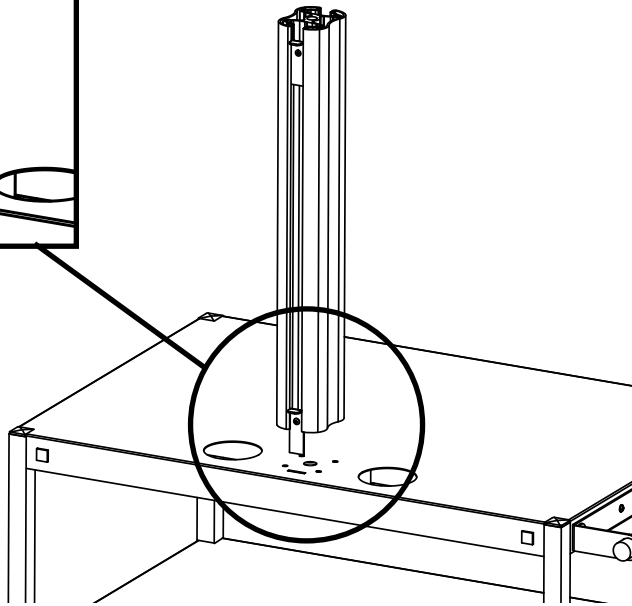

**FIGURE 7**

**STEP 7**

Attach pole to top shelf. Align pole over holes in top shelf as shown in **FIGURE 6**. Secure from **UNDERNEATH** with screw (HH), washer (II), screws (JJ) and washers (KK) as shown in **FIGURE 7**.

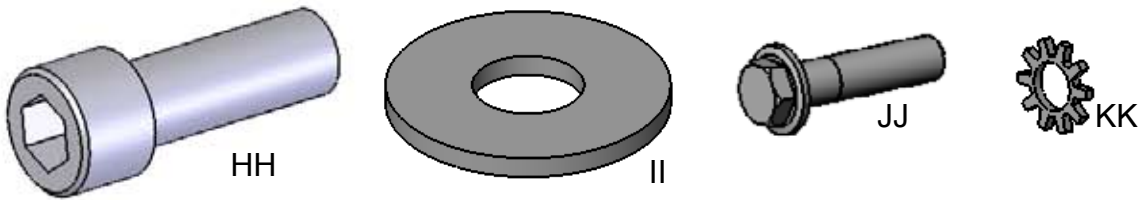

HH

II

JJ

KK

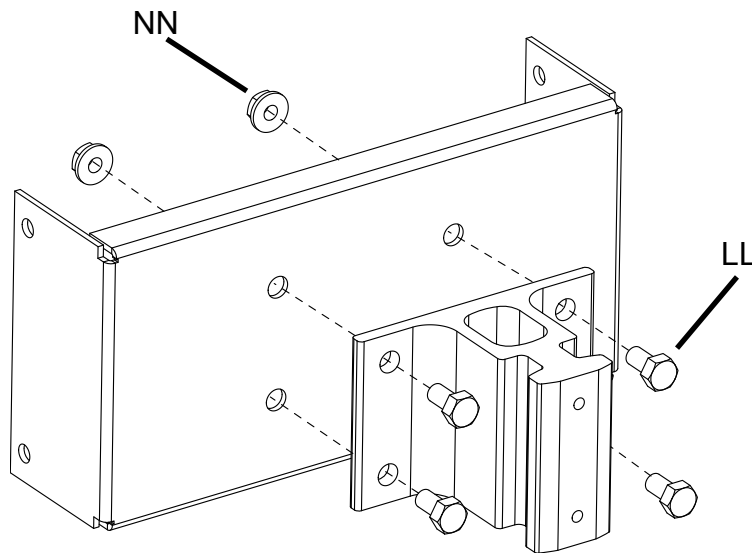

**STEP 8**

Attach the box swivel to the nugget with screws (LL) and nuts (NN) as shown.

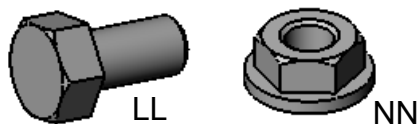

LL

NN

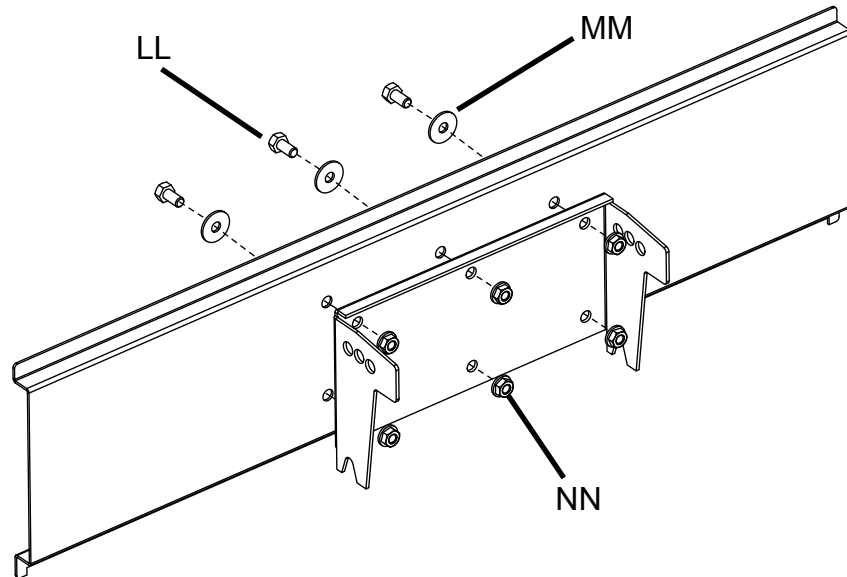

**STEP 9**

Attach main support to swivel bracket with screws (LL), washers (MM) and nuts (NN) as shown.

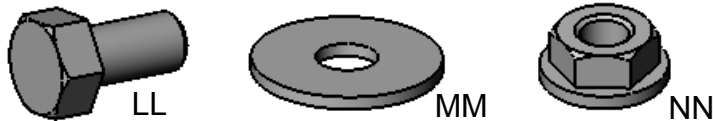

**TILT ADJUSTMENTS**

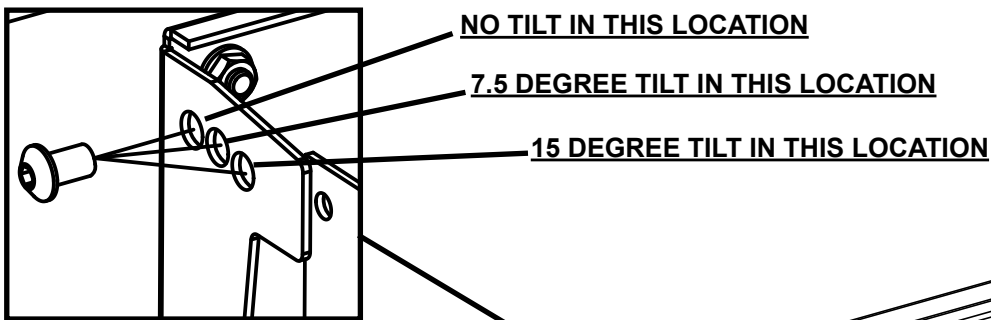

**FIGURE 8**

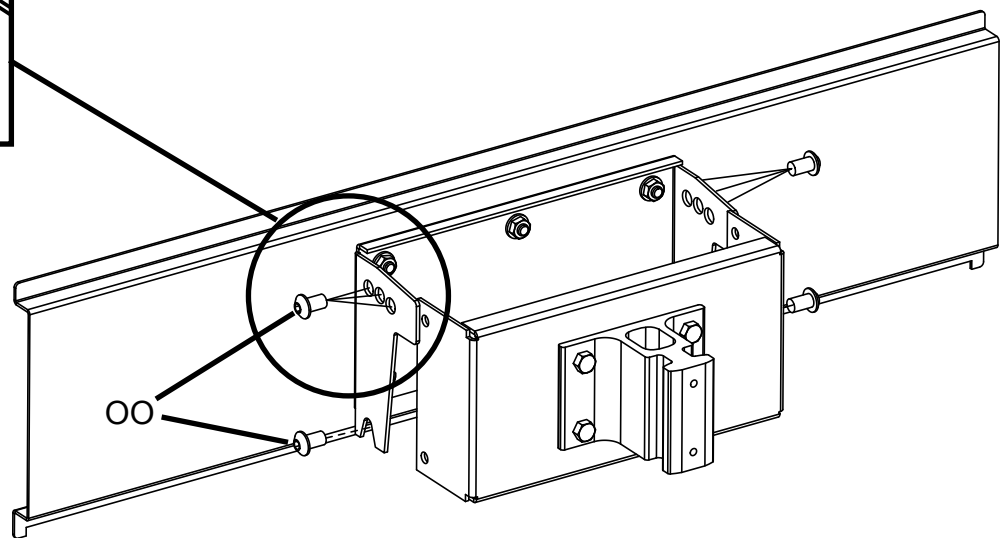

**STEP 10**

Loosely insert the lower spike/box assembly screws (OO) then fit the spike/box assembly notch over the screws and insert the tilt adjustment screws (OO) at the angle desired and tighten all screws. This assembly can be installed with or without a tilt. Reference **FIGURE 8** for tilt adjustments.



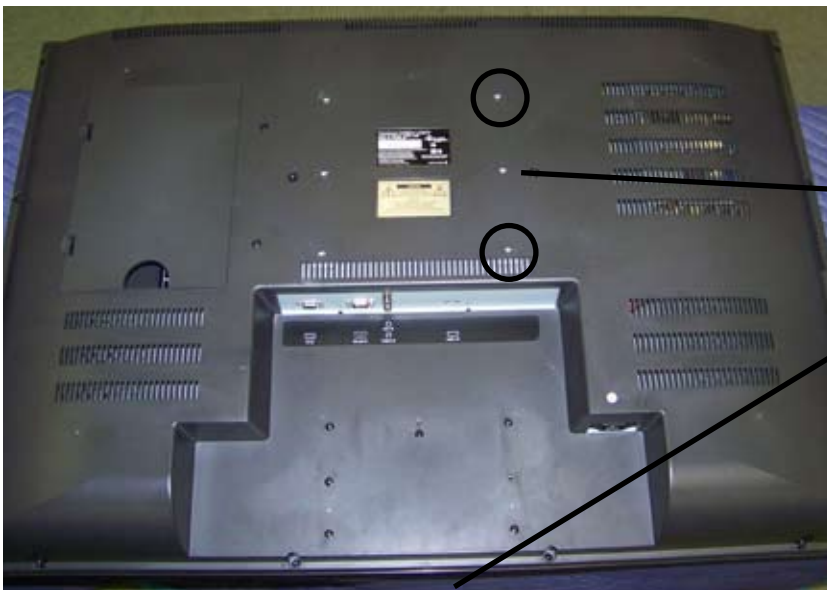

Measure the distance from the center of mount holes to the bottom of the monitor.

**FIGURE 9**

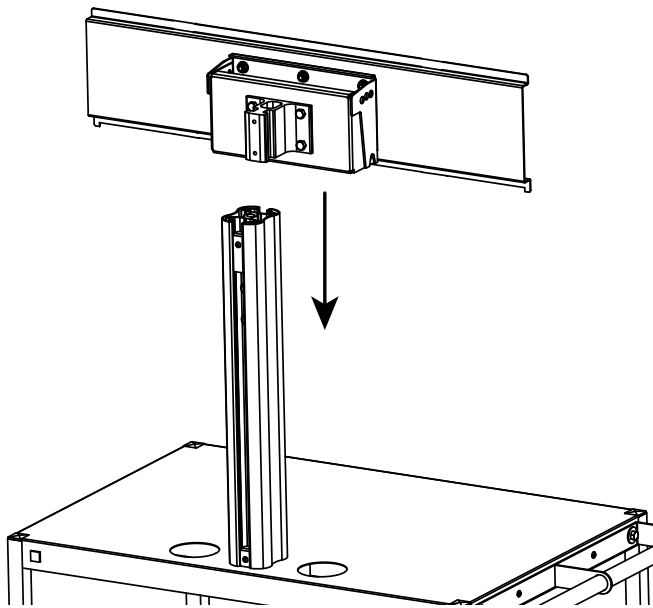

**FIGURE 10**

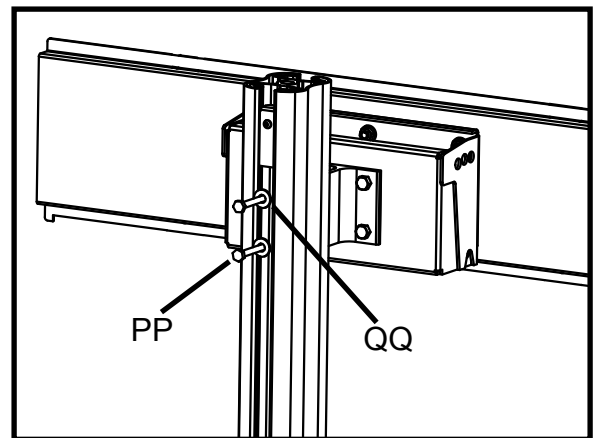

**FIGURE 11**

**STEP 11**

Roughly measure the distance from the center of monitor mounting holes to the bottom of the monitor (**FIGURE 9**). Round to the highest inch and from the top shelf, use that measurement as a guide to the location for the bottom nugget screw on the pole. Slide the nugget assembly onto the pole as shown in **FIGURE 10**. Hand tightening, attach nugget to pole with bolts (PP) and washers (QQ) as shown in **FIGURE 11**. **NOTE:** You may need to adjust the mounting assembly up or down once the monitor is hung in place. **DO NOT OVER TIGHTEN THE BOLTS.**

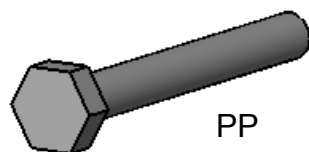

PP



QQ

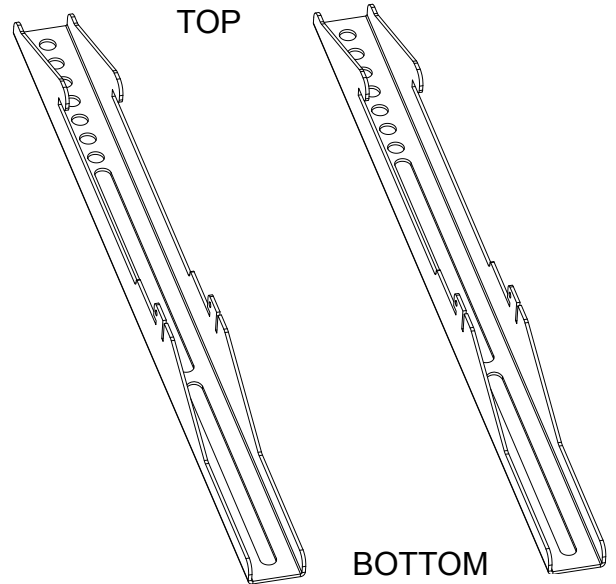

**STEP 12**

Attach both hook bars onto the back of your monitor using the mounting holes built into the case. A courtesy hardware pack has been provided with several metric screw sizes. You may need to purchase additional metric screws from your local hardware store for odd shaped monitors.

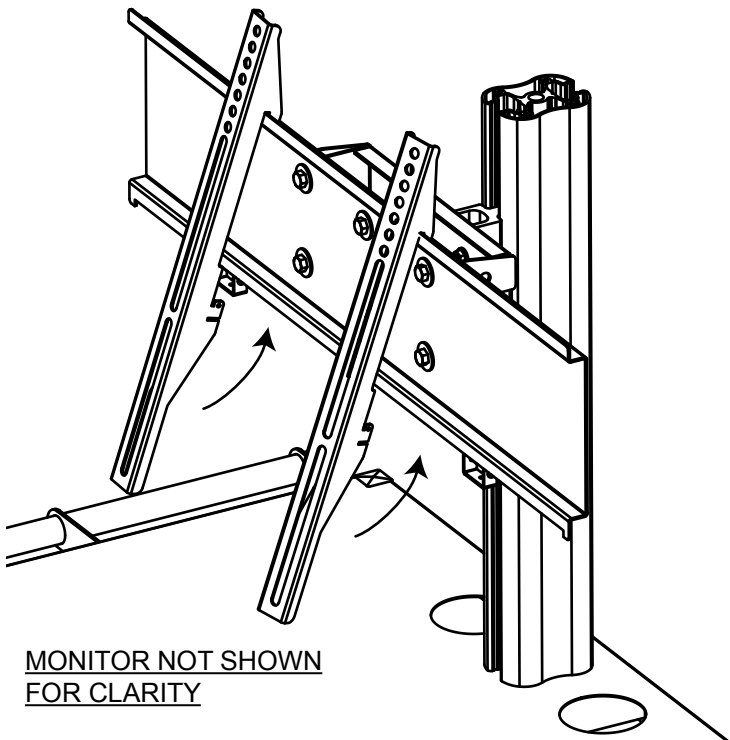

**STEP 13**

Hook monitor onto main support bar as shown. Monitor removed from picture for clarity.

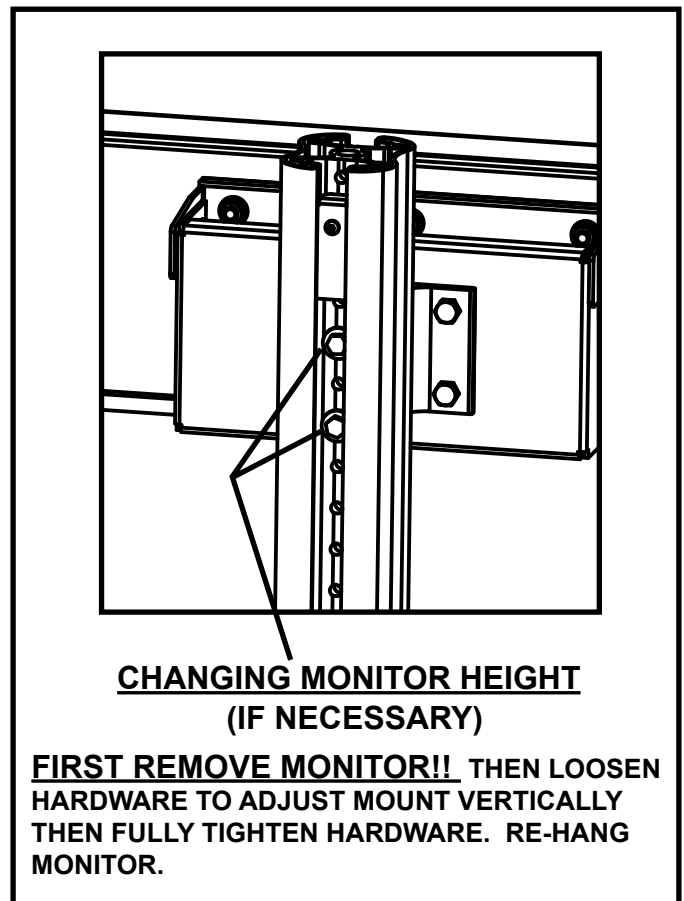

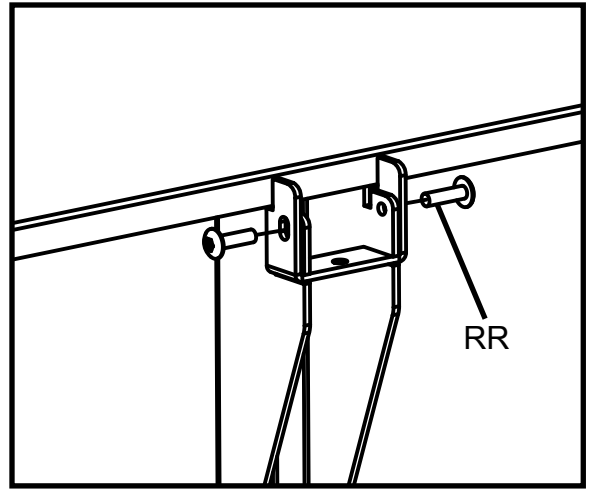
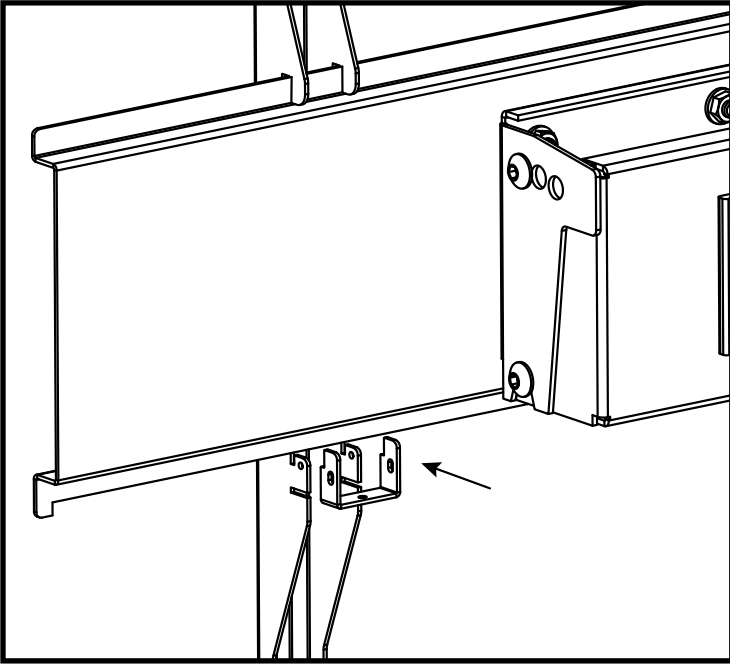

**STEP 14**

Attach the stop brackets to the hook bars as shown with security screws (RR) using the driver bit provided.

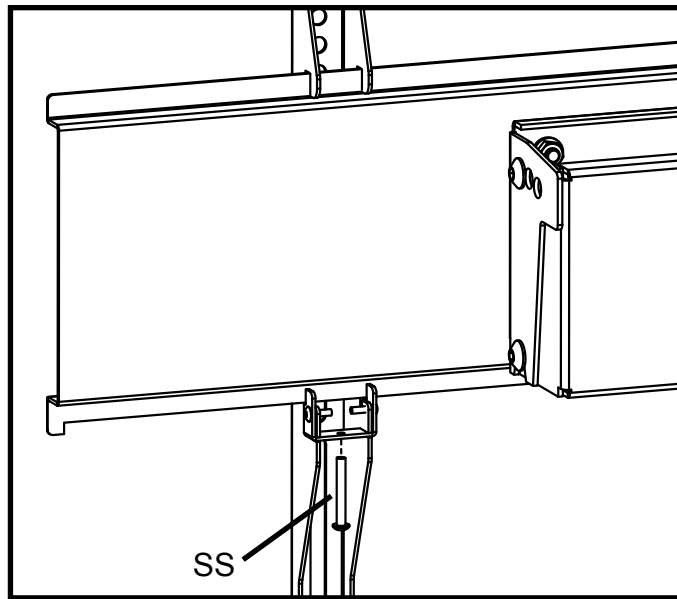

**CENTER MONITOR HORIZONTALLY THEN SECURE**

**STEP 15**

Center your monitor horizontally and then tighten in place with screws (SS).

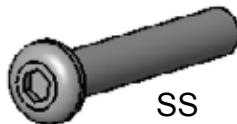

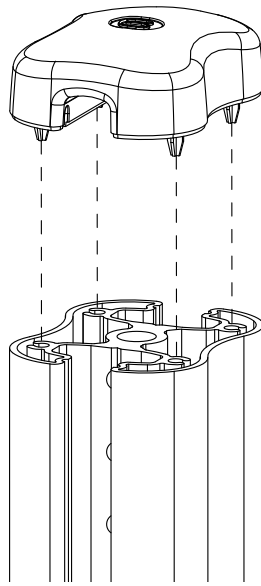

### STEP 16

Snap pole cap onto the top of the pole as shown.

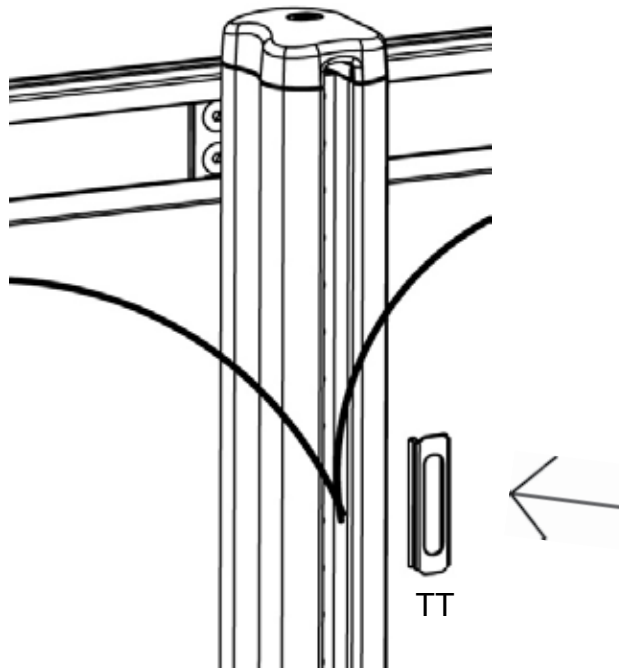

### STEP 17

Feed your power cord into pole channel then snap the plastic clip (TT) inside pole to trap and contain power cord. Cords may be fed into the front or rear pole channel.

Bretford  
11000 Seymour Avenue  
Franklin Park, IL 60131  
TEL: 847.678.2545  
800.521.9614  
FAX: 847.678.0852  
800.343.1779

Bretford Ltd.  
2 Etongate  
110 Windsor Road, Slough  
Berkshire SL1 2JA England  
TEL: 011 44 17 5353 9955  
FAX: 011 44 17 5353 9478

[www.bretford.com](http://www.bretford.com)