

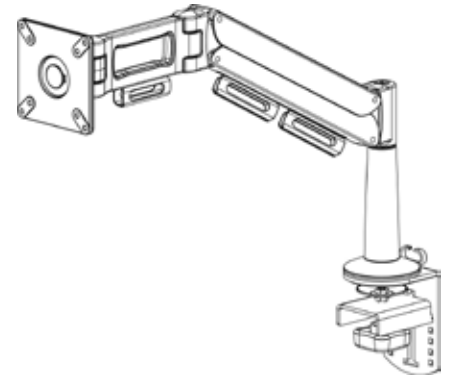

FPSM-D-ADJ1-AL FPSM-D-ADJ1XX-AL
 FPSM-D-ADJ2-AL FPSM-D-ADJ2XX-AL

ADJUSTABLE DESK MOUNTS -
 SINGLE ARM AND DUAL ARM

Assembly Instructions

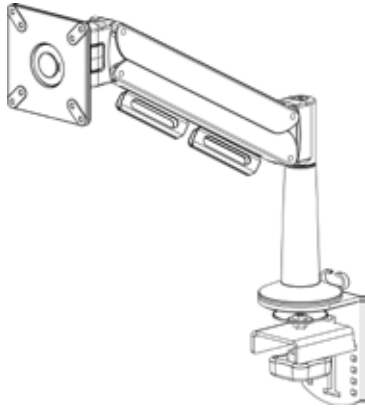

CAUTION:

This mount is intended to support a LCD monitor having a diagonal screen size of 22.9". Models FPSM-D-ADJ1-AL & FPSM-D-ADJ2-AL are intended for LCD monitors with a maximum weight of 15 lbs. Models FPSM-D-ADJ1XX-AL & FPSM-D-ADJ2XX-AL are intended for LCD monitors weighing 15 to 30 lbs. Use of any larger size monitors may result in instability causing possible injury. A qualified professional should be used to properly install mount and correct mounting hardware. Bretford will not be liable for the improper use or installation of its products.

Hardware List

Ref.	Qty.	Part No.	Description
AA	4	030-0845	M4 x 0.7 , 20mm Phillips Pan Head Screws
BB	4	030-1234	M4 x 0.7 , 12mm Phillips Pan Head Screws
CC	1	030-1222	5/16-18 x 5 1/2" Cap Head Screw
DD	1	030-0306	1" x 21/64" x 1/16" Washer
EE	2/3*	012-0760	Cable Clips *(2) for ADJ1 Models (3) for ADJ2 Models
	2/3*	012-0815	Cable Clips *(2) for ADJ1 Models (3) for ADJ2 Models
	1	031-5438	Adhesive Pad
	3	031-1823	Velcro Loop
	1	030-0397	3/16" Allen Wrench

Adhesive Pad (031-5438)

**Only attach if using
 the clamp option**

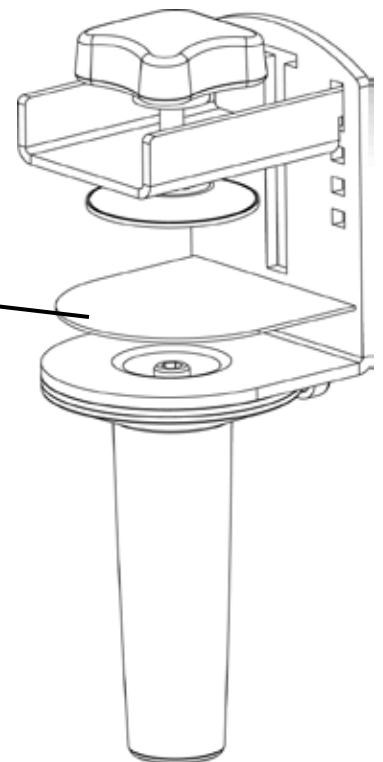

STEP 1

If you are using the clamp option, peel and stick adhesive pad onto clamp base as shown.

FOLLOW EITHER STEP 2A OR STEP 2B FOR YOUR DESIRED APPLICATION

CLAMPING TO A DESK

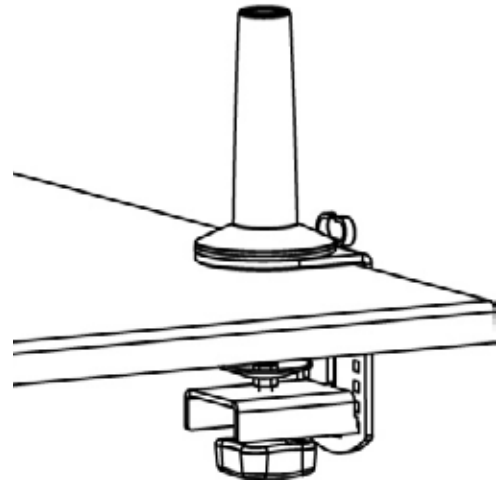
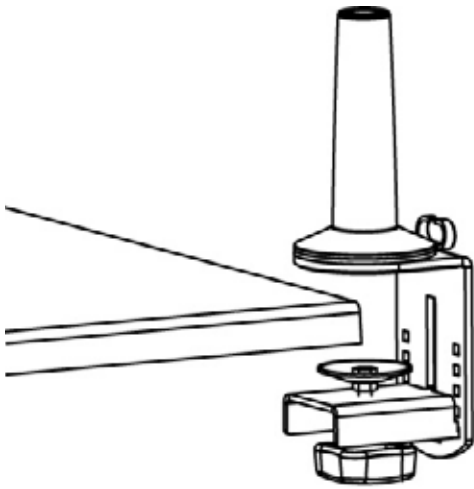

STEP 2A

Slide clamp assembly onto your desk in desired location. Turn knob until clamp is securely in place.

NOTE: Using the clamp option may flex based upon your furniture or horizontal mounting surface you choose to use. The bolt-thru and wall mount options are the most secure.

BOLTING TO A DESK

Disassemble

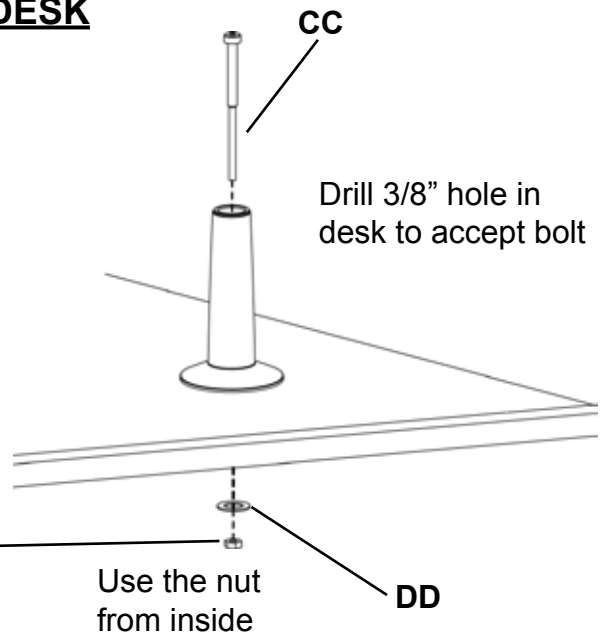
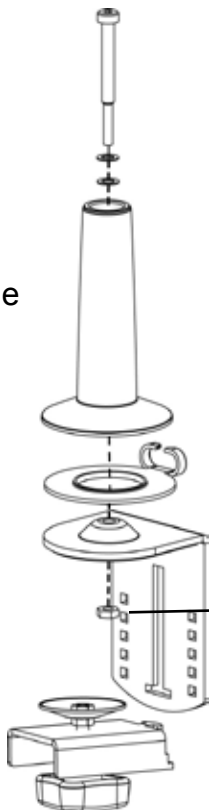

STEP 2B

Using 3/16" Allen wrench provided, disassemble the clamp assembly. The drill a 3/8" hole in your desired location. Secure arm base to desk with bolt (CC) and washer (DD) and nut indicated.

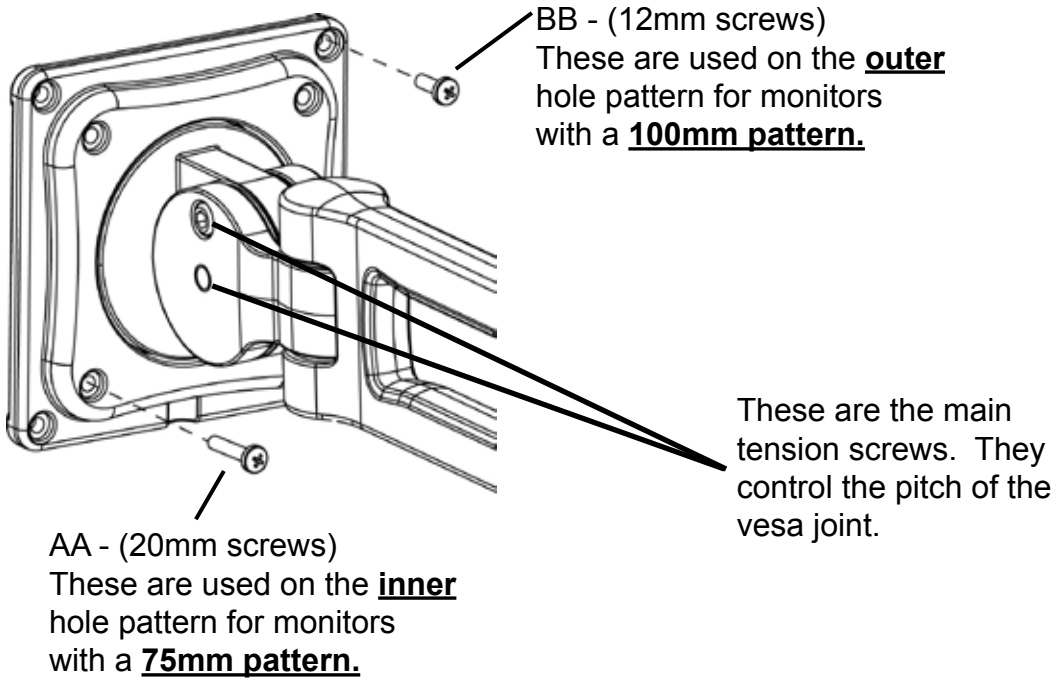

STEP 3

Attach your monitor to the vesa plate with either screws (AA) or (BB) as indicated above. **NOTE:** The screws that came with your monitor may be sufficient for mounting to the vesa plate. As long as they are a M4 type screw and sufficient in length.

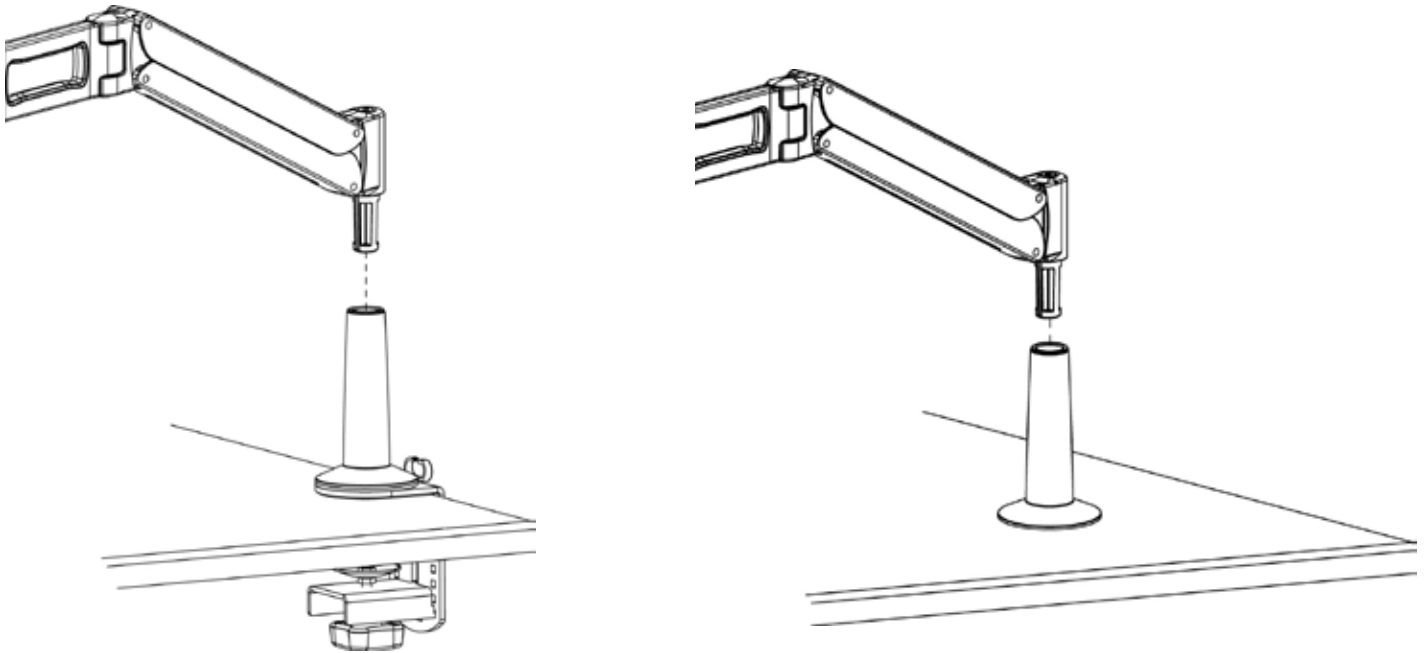

STEP 4

Insert the adjustable arm into the base arm as shown.

NOTE: 2 different sets of plastic clips are provided for the best possible fit.

Fold plastic cable clip closed.

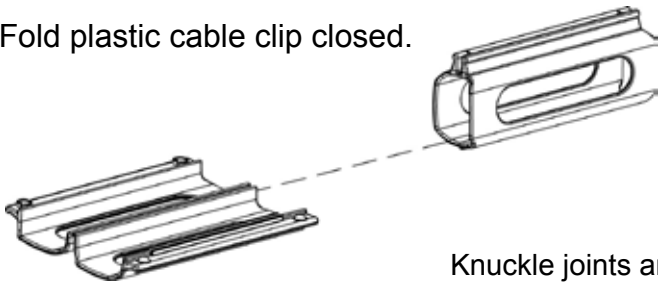

Knuckle joints are preset to correct tension. No adjustments are needed.

If necessary, use the 3/16" Allen wrench for adjusting the cylinder tension which could affect the height.

NOTE: Prior to adjusting the tension, evenly distribute the weight on the arm assembly. If not, tension will not be adjusted.

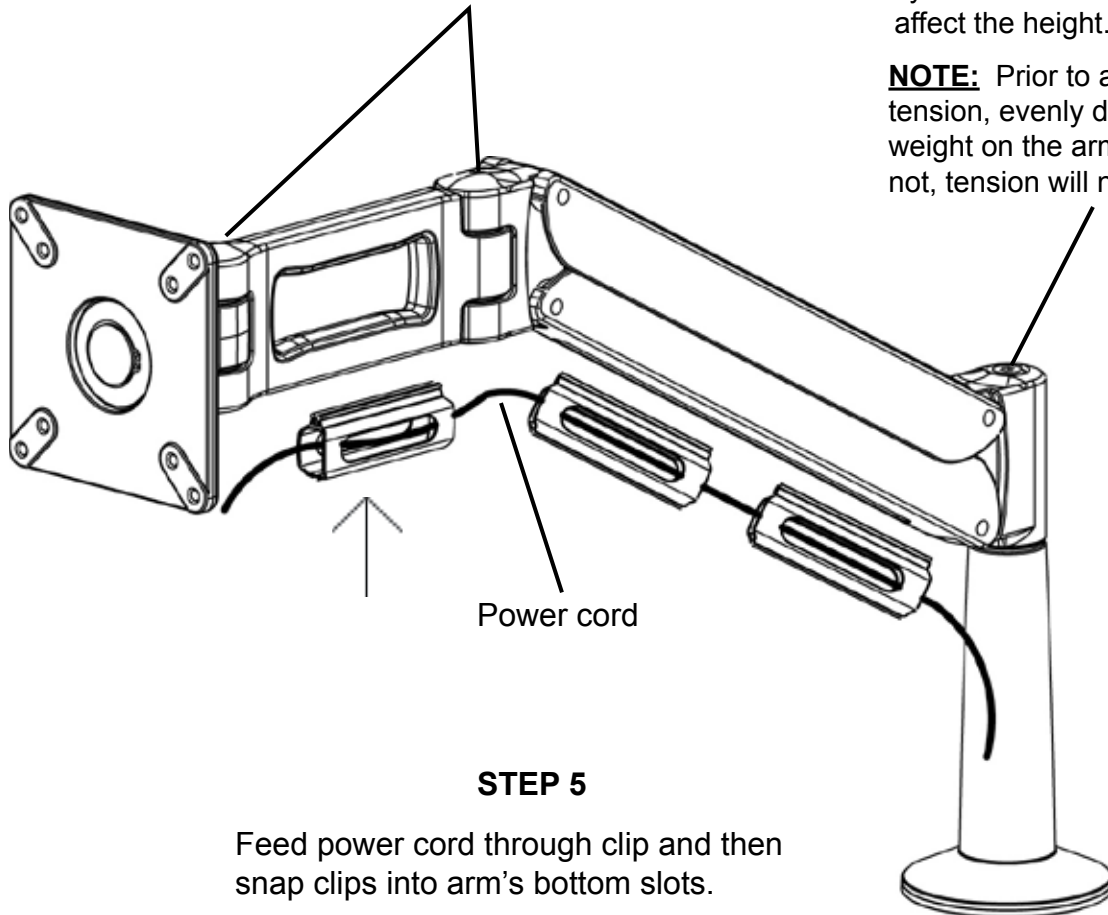

STEP 5

Feed power cord through clip and then snap clips into arm's bottom slots.

Trouble Shooting for Plastic Clips

If your clips are not staying in place try this -

- 1) Take a single piece of Velcro with adhesive on one side.
- 2) Open the clip and attach the single piece of Velcro to one side of the clip with the adhesive side against the clip edge.
- 3) Fold the Velcro over the clip edge so that the adhesive bonds to the other side of the clip edge.
- 4) Gather your cables and fold the cable clip around them, and force the combined clip edges (one with Velcro, one without) into the slot push hard!

Once in the slot, the combined clip edges are pretty much locked in place

Bretford
11000 Seymour Avenue
Franklin Park, IL 60131
TEL: 847.678.2545
800.521.9614
FAX: 847.678.0852
800.343.1779

Bretford Ltd.
2 Etongate
110 Windsor Road, Slough
Berkshire SL1 2JA England
TEL: 011 44 17 5353 9955
FAX: 011 44 17 5353 9478