

FPSM-W-DIS2-AL FPSM-W-DIS3-AL  
 FPSM-W-DIS4-AL FPSM-W-DIS6-AL

SINGLE OR DOUBLE WALL MOUNTS  
 Assembly Instructions

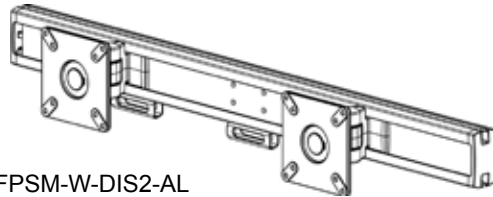

FPSM-W-DIS2-AL

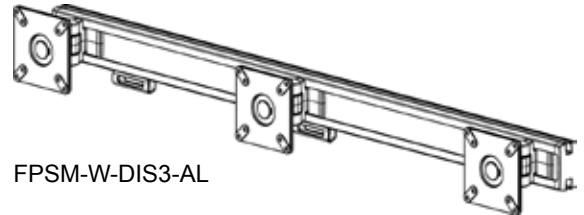

FPSM-W-DIS3-AL

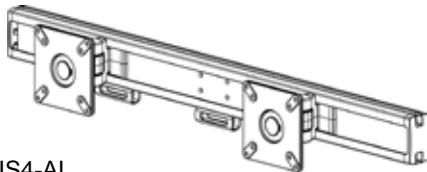

FPSM-W-DIS4-AL

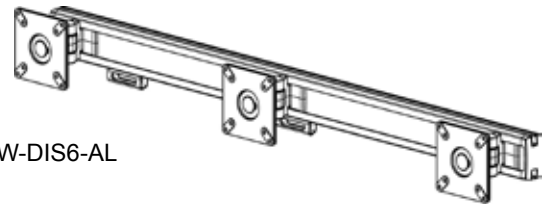

FPSM-W-DIS6-AL

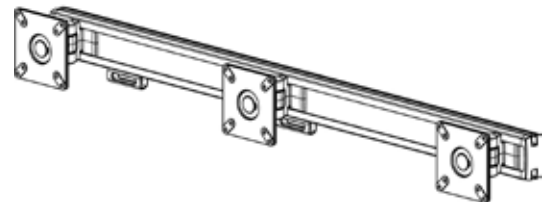
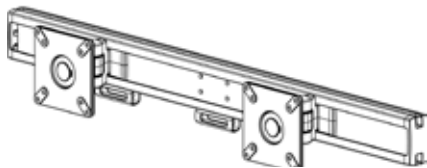

**Parts List**

Qty.	Part No.	Description
1/2	010-4639	Wall Hanging Bracket (1) for DIS2 & DIS3 Models (2) for DIS4 & DIS6 Models
1/2	034-0014	Monitor Mount Beam (1) for DIS2 Model (2) for DIS4 Model
1/2	034-0015	Monitor Mount Beam (1) for DIS3 Model (2) for DIS6 Model
*	Vesa Plates	* (2) for DIS2 Model * (3) for DIS3 Model * (4) for DIS4 Model * (6) for DIS6 Model
2/4	012-0755	Plastic End Caps (2) for DIS2 & DIS3 Models (4) for DIS4 & DIS6 Models

**Hardware List**

Ref.	Qty.	Part No.	Description
AA	2/4	030-0374	1/4" x 2 1/2" Lag Screws
BB	1/2	030-1220	5/16-18 x 1" Set Screws (1) for DIS2 & DIS3 Models (2) for DIS4 & DIS6 Models
CC	8*	030-0845	M4 x 0.7 , 20mm Phillips Pan Screws * (8) for DIS2 Model * (12) for DIS3 Model * (16) for DIS4 Model * (24) for DIS6 Model
DD	8*	030-1234	M4 x 0.7 , 12mm Phillips Pan Screws * (8) for DIS2 Model * (12) for DIS3 Model * (16) for DIS4 Model * (24) for DIS6 Model
EE	2*	012-0760	Cable Clips & 012-0815 * (2) for DIS2 Model * (3) for DIS3 Model * (4) for DIS4 Model * (6) for DIS6 Model
	1	030-0397	3/16" Allen Wrench
	1	HK1020	5/32" Allen Wrench

**CAUTION:** This mount is intended to support a LCD monitor each having a diagonal screen size of 22.9" and a maximum weight of 25 lbs. Use of any larger size monitors may result in instability causing possible injury. The wall mounting hardware included in your hardware pack is **INTENDED** for **WOOD STUD INSTALLATION ONLY**. For added safety and ease of installation, use a qualified professional to properly install the correct mounting hardware. Bretford will not be liable for the improper use or installation of its products.

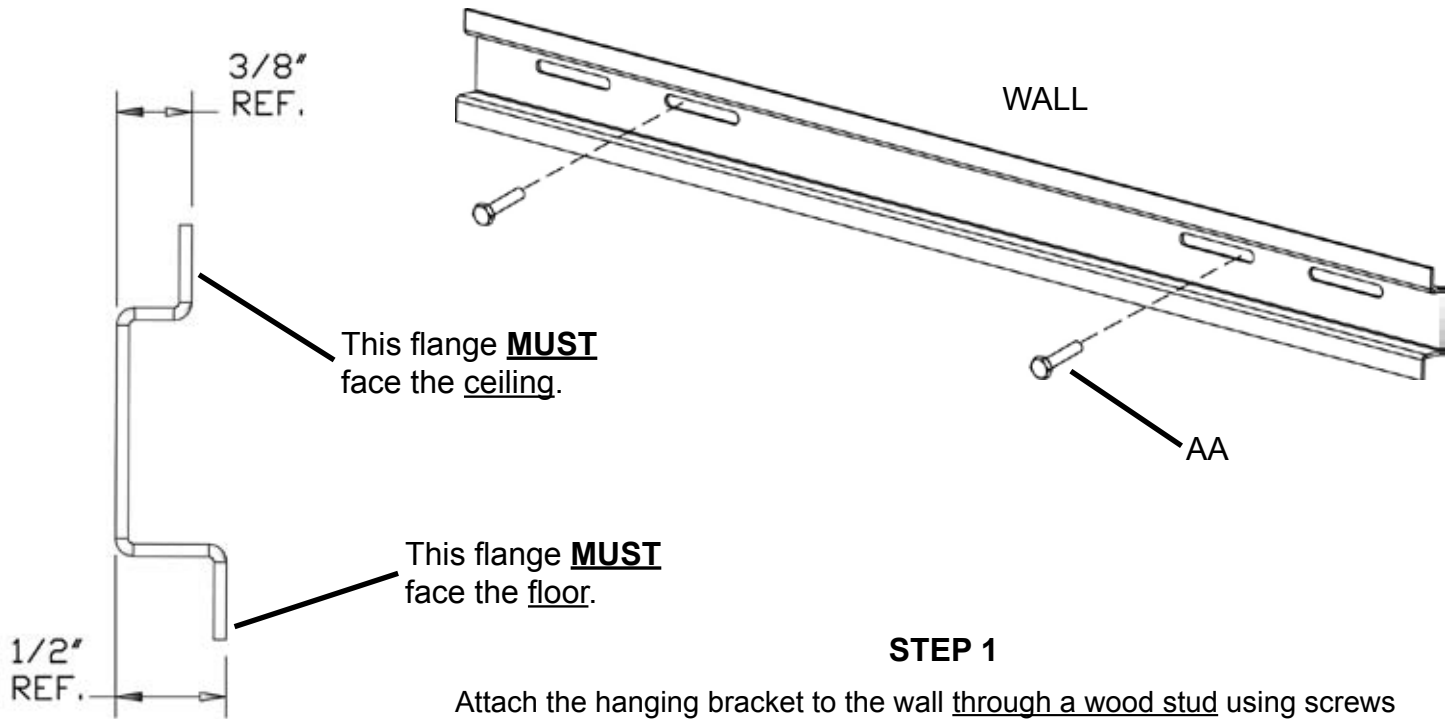

**BRACKET SIDE VIEW**

**STEP 1**

Attach the hanging bracket to the wall through a wood stud using screws (AA) as shown. **NOTE:** The slots used depends on your spacing between studs. Use the bracket side view for bracket's correct position on your wall.

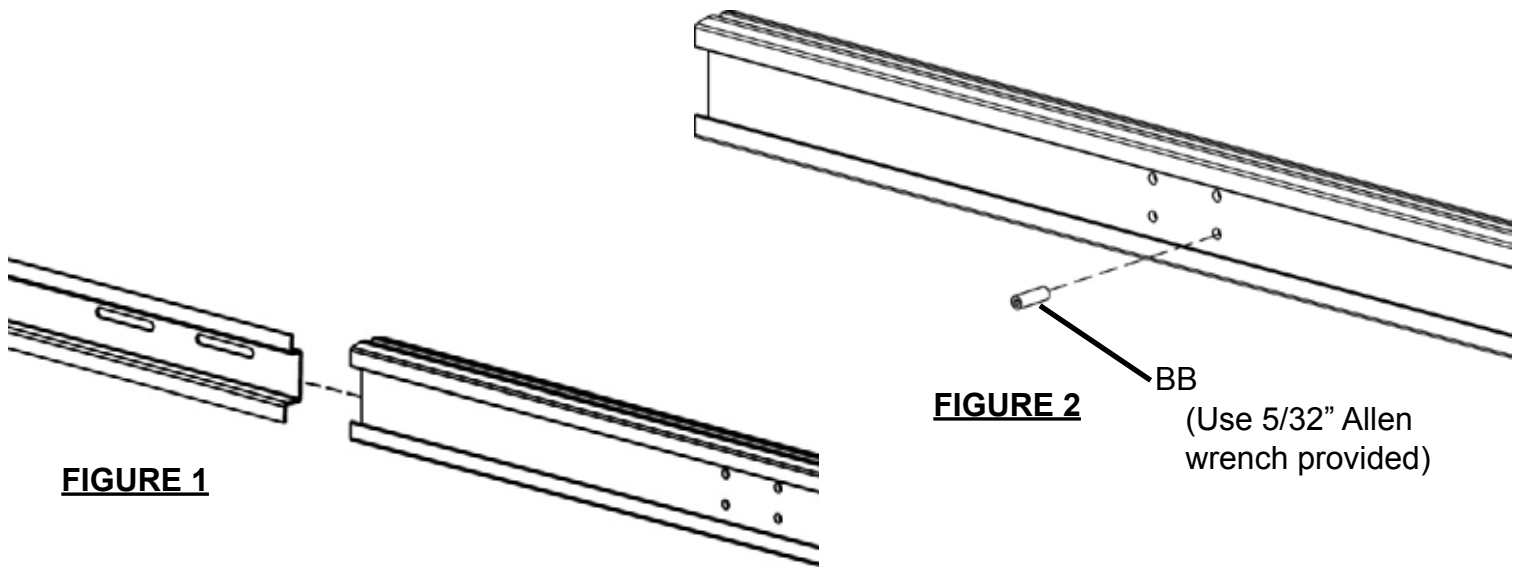
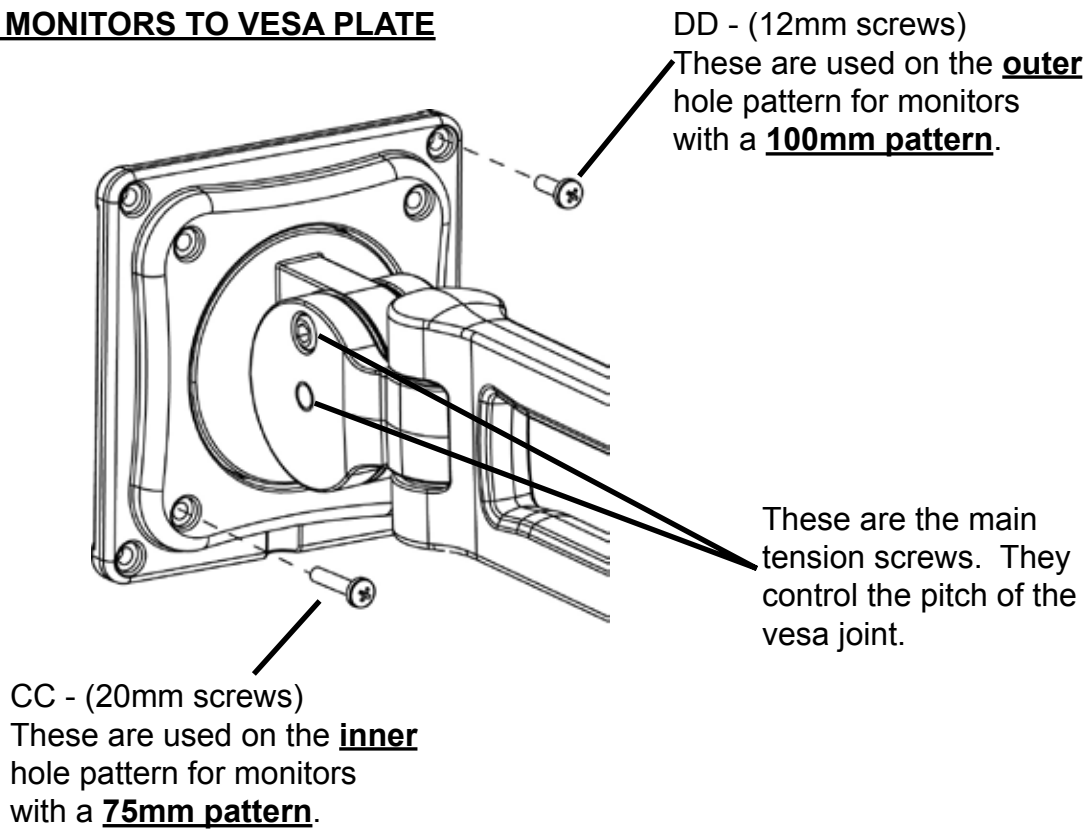

**FIGURE 2**  
BB  
(Use 5/32" Allen wrench provided)

**STEP 2**

Slide beam onto hanging bracket as shown in **FIGURE 1**. Then center beam on bracket and secure in place with screws (BB) as shown in **FIGURE 2**.

## MOUNT MONITORS TO VESA PLATE



### **STEP 3**

Attach your monitor to the vesa plate with either screws (CC) or (DD) as indicated above. **NOTE:** The screws that came with your monitor may be sufficient for mounting to the vesa plate. As long as they are a M4 type screw and sufficient in length.

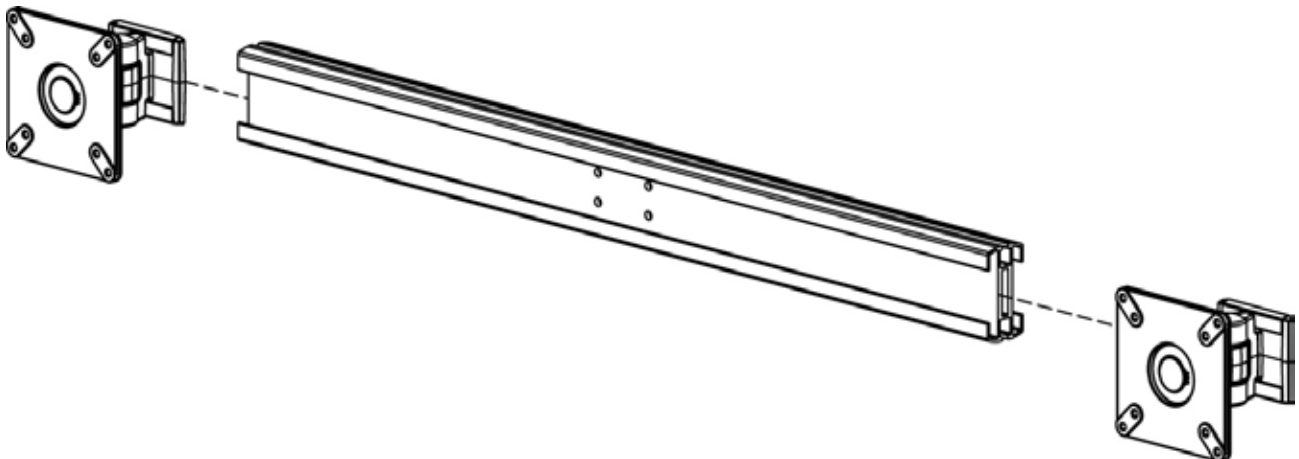

### **STEP 4**

Slide each vesa plate assembly onto the beam as shown. **NOTE:** Monitors are removed for clarity.

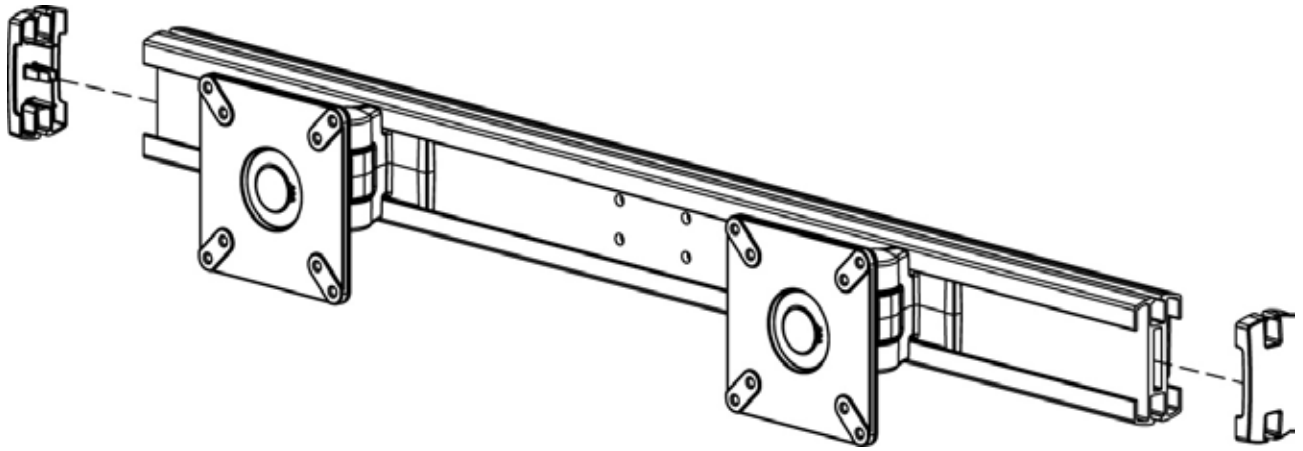

### STEP 5

Snap the end caps onto the ends of the beam as shown.

Fold plastic cable clip closed.

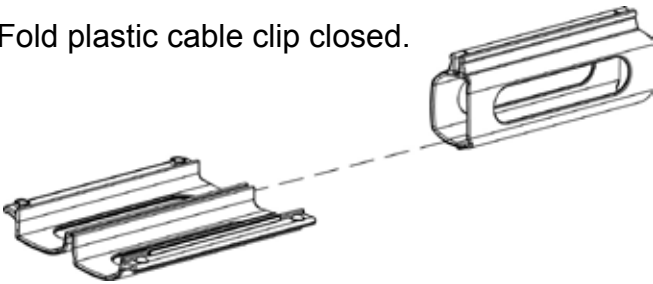

**NOTE:** 2 different sets of plastic clips are provided for the best possible fit.

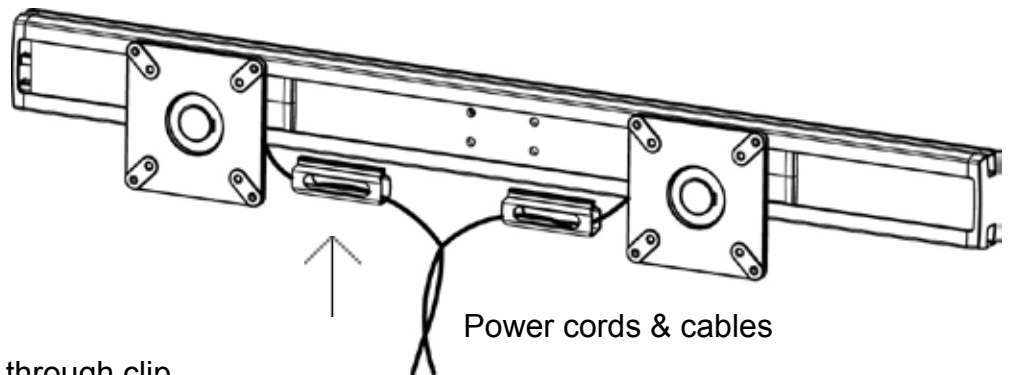

Feed power cords through clip and then snap clip into beam's bottom slot.

Bretford  
11000 Seymour Avenue  
Franklin Park, IL 60131  
TEL: 847.678.2545  
800.521.9614  
FAX: 847.678.0852  
800.343.1779

Bretford Ltd.  
2 Etongate  
110 Windsor Road, Slough  
Berkshire SL1 2JA England  
TEL: 011 44 17 5353 9955  
FAX: 011 44 17 5353 9478