

FPPSP31 FPPSP42  
**SPEAKER BARS**  
 Assembly Instructions

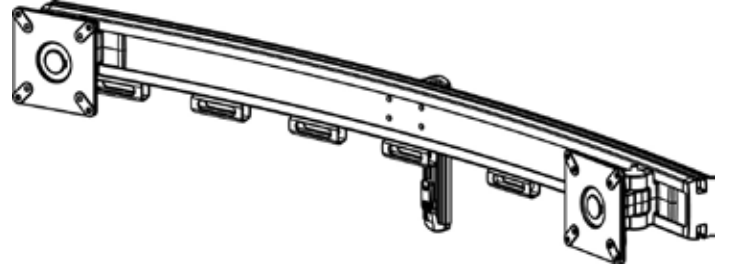
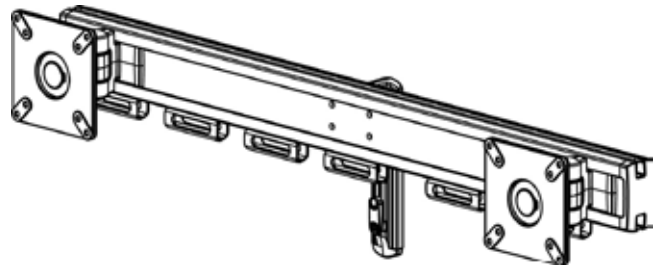

**Parts List**

Qty.	Description
1	Beam Extrusion for FPPSP31 (034-0014)
1	Beam Extrusion for FPPSP42 (034-0003)
1	Spike Assembly
2	Vesa Plate Mount Assemblies
2	Plastic End Caps (012-0755)

**Hardware List**

Ref.	Qty.	Part No.	Description
AA	4	030-1165	5/16-18 UNC, 1/2" Flat Hd Screws
BB	6	012-0760	Cable Clips
	6	012-0815	Cable Clips
	1	030-0397	3/16" Allen Wrench

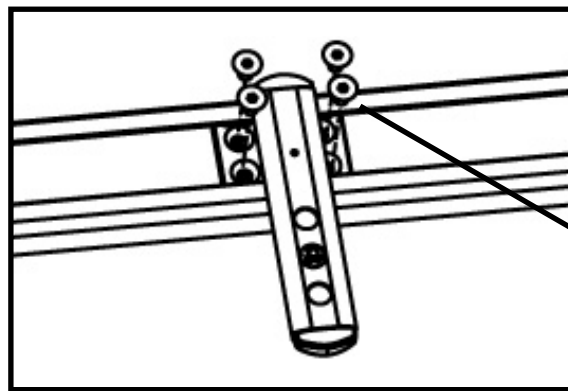
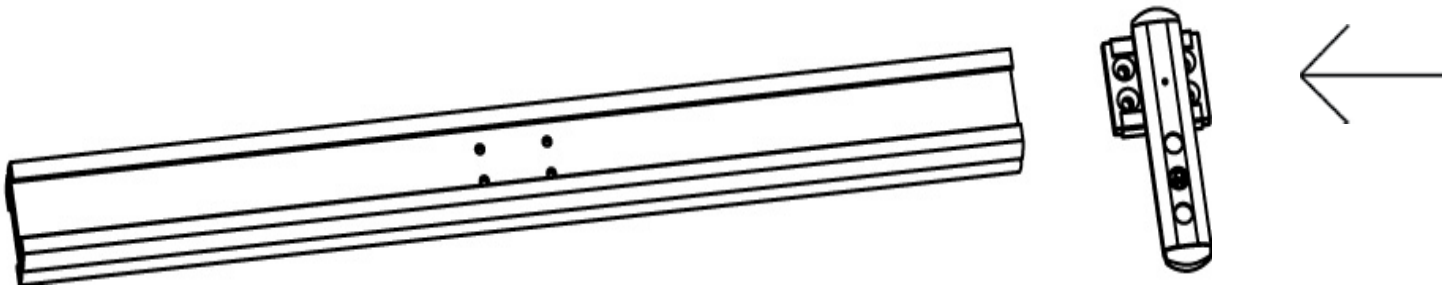

AA  
 (Use 3/16" Allen wrench provided)

**STEP 1**

Slide spike assembly onto the beam. Line the spike up with the center holes and attach with screws (AA) as shown.

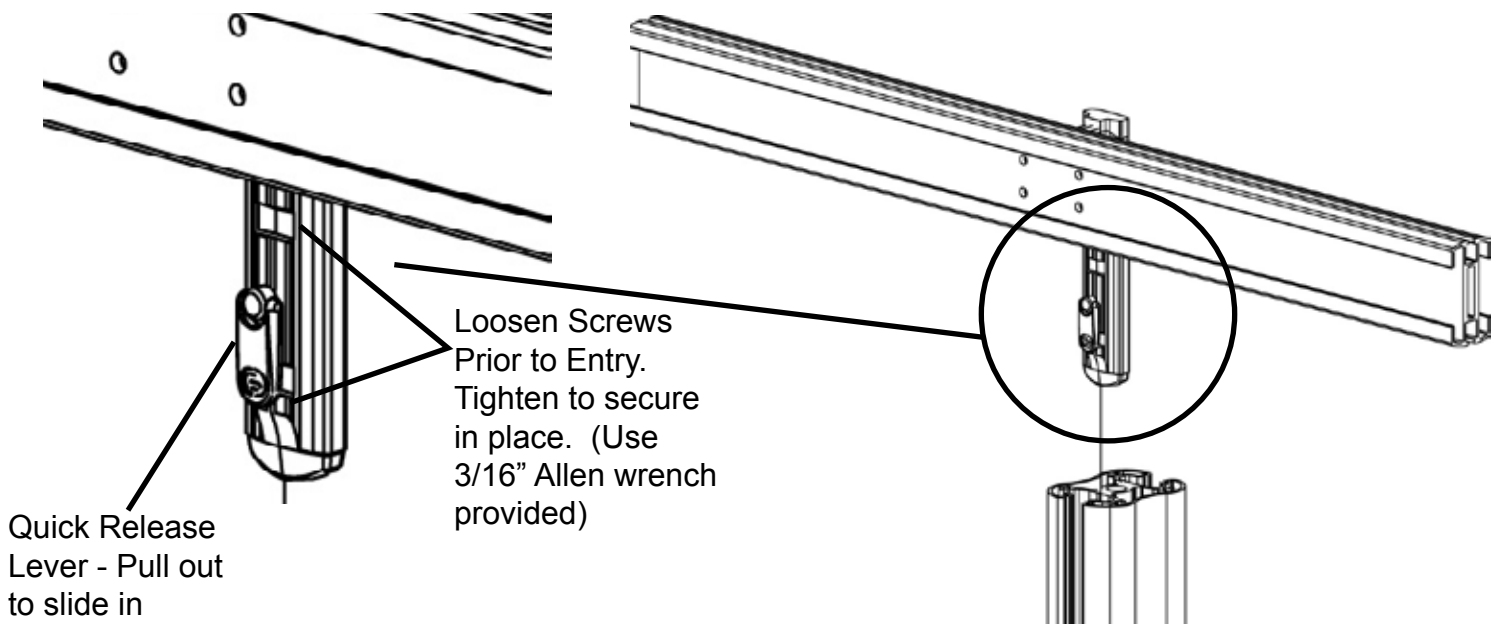

### STEP 2

With someone's help, slide the monitor mount assembly into the pole. **NOTE:** Make sure the screws in the spike are loosened and the release lever is pull out while sliding in spike. Once desired location is determined, tighten spike screws.

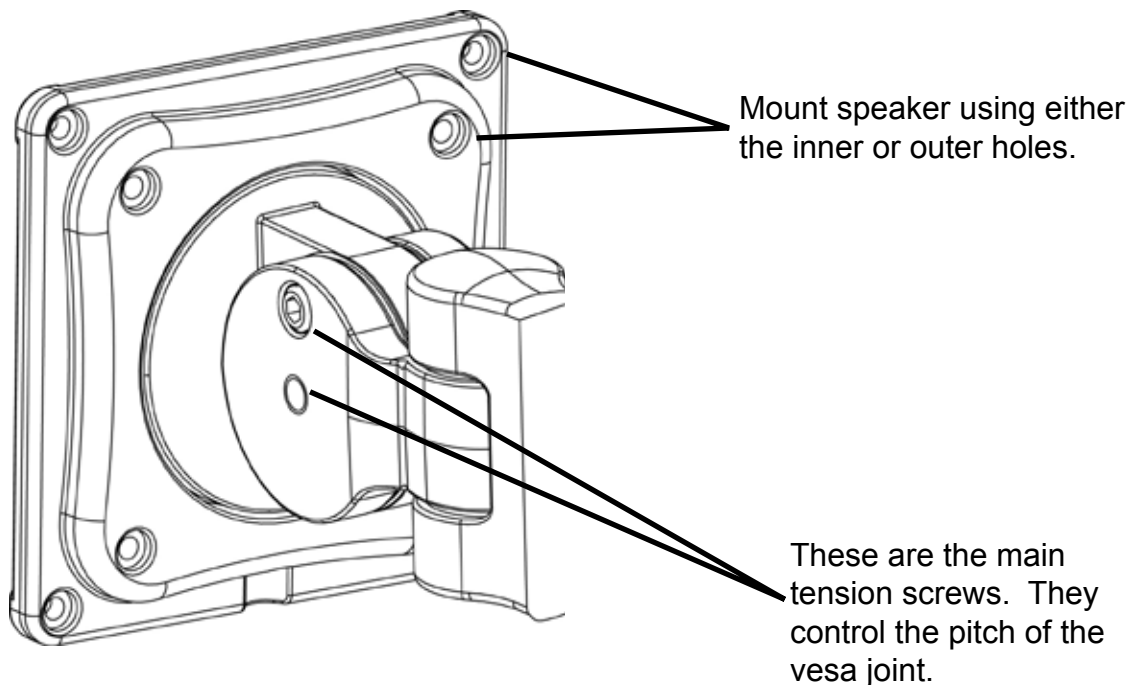

### STEP 3

Mount your speakers onto the vesa plates. Depending on the type of speakers either use the 4 outer or 4 inner holes for mounting. Do to the variety of speakers, hardware is not provided. You need to determine the correct mounting hardware for your speaker.

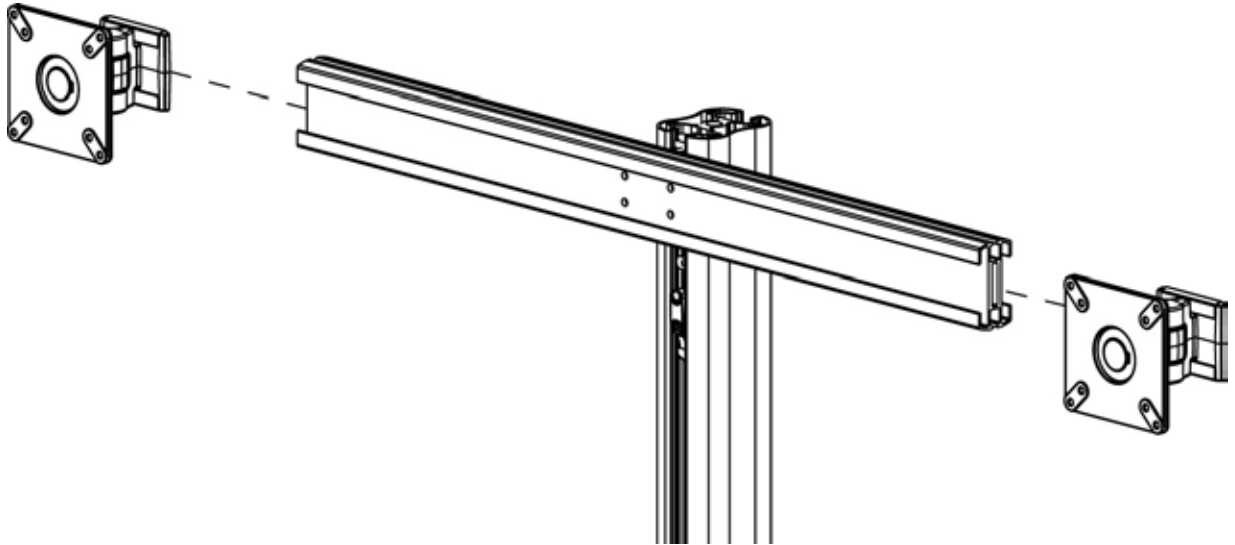

#### STEP 4

**FIRST**, mount your speakers onto the vesa plates. Then slide each mounting plate onto the beam as shown.

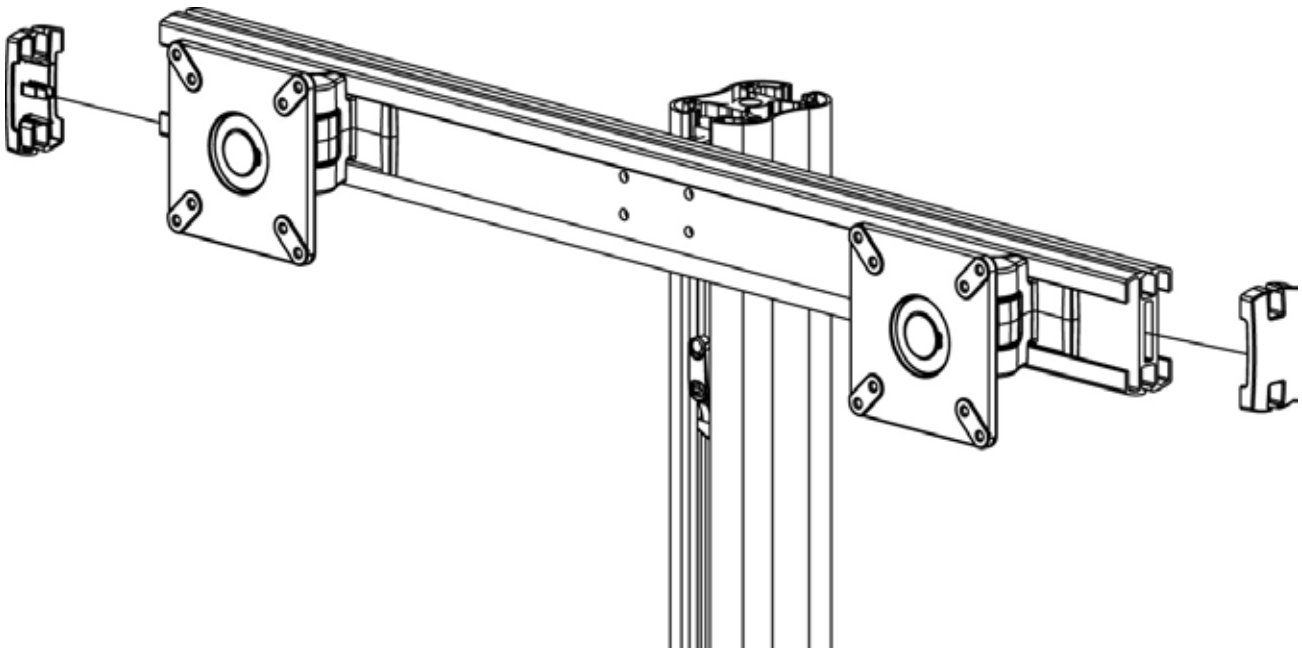

#### STEP 5

Snap on the beam end caps as shown.

Fold plastic cable clip closed.

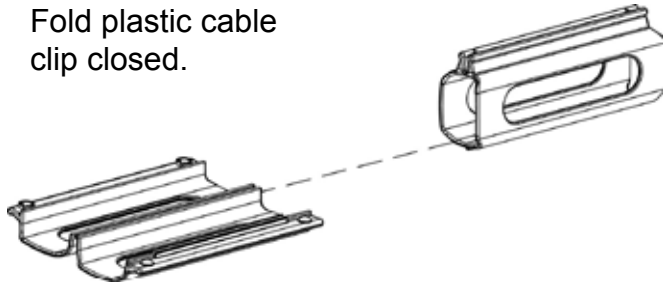

**NOTE:** 2 different sets of plastic clips are provided for the best possible fit.

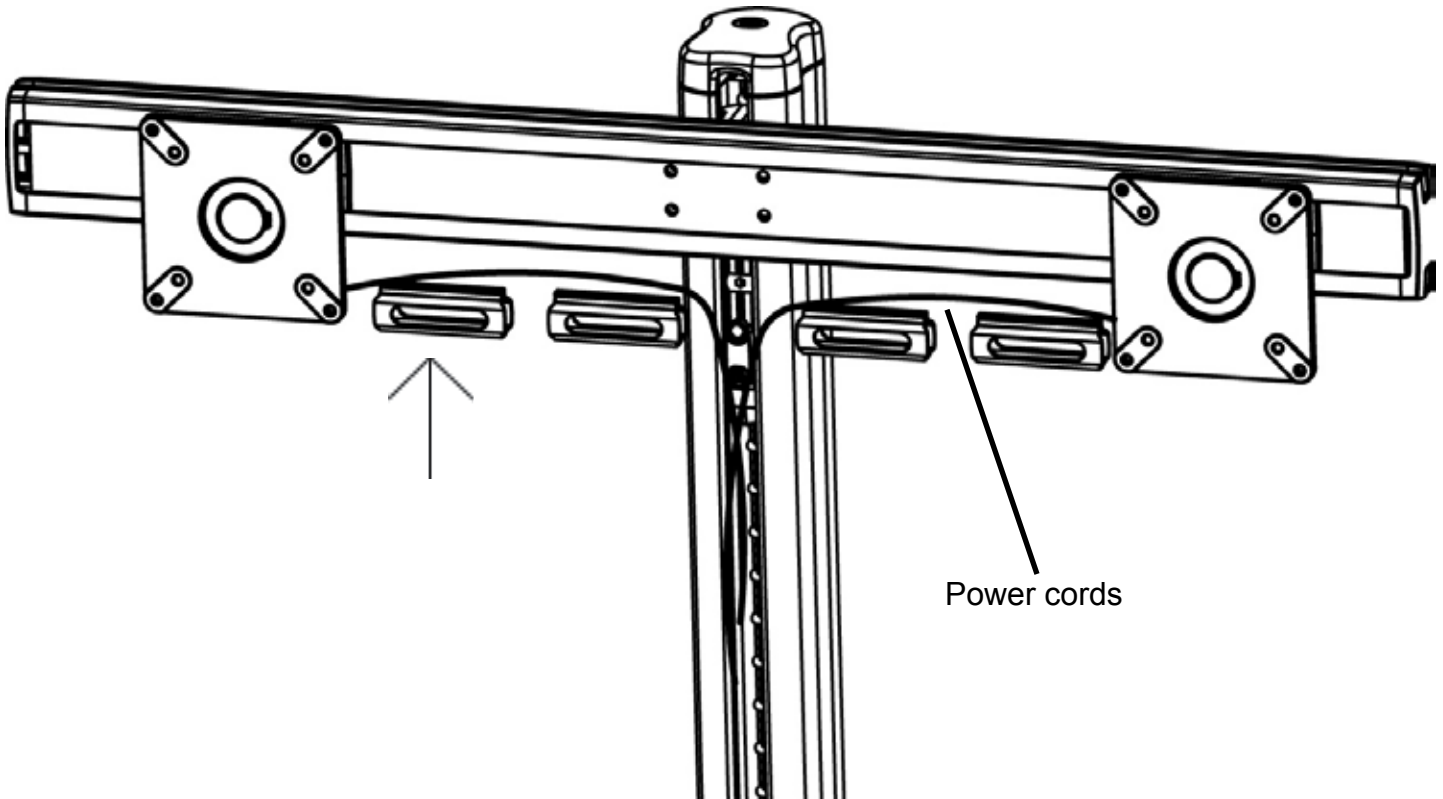

Feed power cords through clip and then snap clips into beam's bottom slots.

Bretford  
11000 Seymour Avenue  
Franklin Park, IL 60131  
TEL: 847.678.2545  
800.521.9614  
FAX: 847.678.0852  
800.343.1779

Bretford Ltd.  
2 Etongate  
110 Windsor Road, Slough  
Berkshire SL1 2JA England  
TEL: 011 44 17 5353 9955  
FAX: 011 44 17 5353 9478

[www.bretford.com](http://www.bretford.com)