

35FS69 35FS21
35FS65 35FS67

Flat Screen Table with Glides and CPU Holder
Assembly Instructions

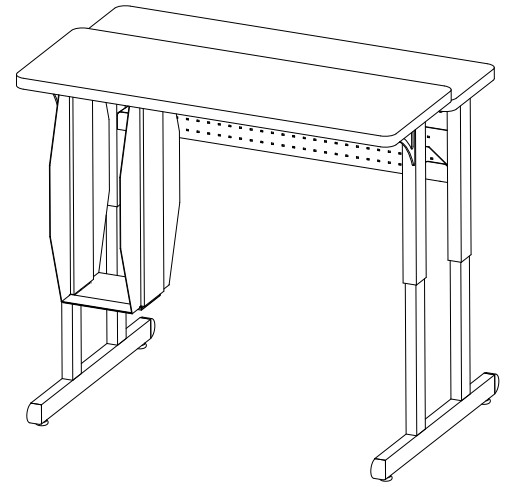

Parts List

Qty.	Part No.	Description	Qty.	Ref.
1	SA2361	Front Top - 13"D x 36"L	16	AA
	SA2363	Front Top - 13"D x 72"L	1	BB
1	SA2359	Rear Top - 15 1/2"D x 36"L		
	SA2362	Rear Top - 9 1/2"D x 36"L	8	CC
	SA2364	Rear Top - 9 1/2"D x 72"L	3	DD
	SA2360	Rear Top - 15 1/2"D x 72"L		
1	022-2321	36" One Piece Frame for Front Top	2	EE
	022-2322	72" One Piece Frame for Front Top	2	FF
1	022-2319	Upper Left Leg for Rear Top	3	GG
1	022-2320	Upper Right Leg for Rear Top		
2	022-2371	24" One Piece Lower Leg Assembly	6	HH
	022-2324	30" One Piece Lower Leg Assembly		
1	010-3980	36" Modesty Panel	4	II
	010-3981	72" Modesty Panel	1	JJ
1	010-3343	XTC CPU Holder Side w/Slot		
	010-4980	CPU Holder w/Slot for MT Models (2 Required for 35FS65 & 35FS67)	1	KK
1	010-3344	XTC CPU Holder Side w/Hole	1	LL
	010-4981	CPU Holder w/Hole for MT Models (2 Required for 35FS65 & 35FS67)	1	
			1	

Hardware List

Part No.	Description
030-0253	1/4-20 x 3/4" Combo Screws
SC1047B	1/4-20 x 37.5mm Connector Bolt (2 required on 35FS65 & 35FS67)
030-0396	3/8-16 x 1/2" Socket Set Screw
030-0168	#8 x 1/2" Wood Screws (4 required on 35FS65 & 35FS67)
030-0325	1/4-20 x 1/2" Combo Screws
030-0256	1/4-20 Flange Nuts
030-0453	#12 x 3/4" Phillips Truss Hd Screws (6 required on 35FS65 & 35FS67)
030-0305	7/8" x 17/64" x 1/16" Washers (12 required on 35FS65 & 35FS67)
015-0045	Adjustable Non-Swivel Glides
030-0272	1/4-20 x 1/2" Carriage Bolt (2 required on 35FS65 & 35FS67)
030-0306	1" x 21/64" x 1/16" Washer (2 required on 35FS65 & 35FS67)
030-0256	1/4-20 Flanged Nut (2 required on 35FS65 & 35FS67)
030-0397	Allen Wrench
HK1020	Hex Key

Tools Required

Phillips Screwdriver
Allen Wrench
7/16" Open/Box End Wrench
Electric Drill
1/8" Dia. Drill Bit

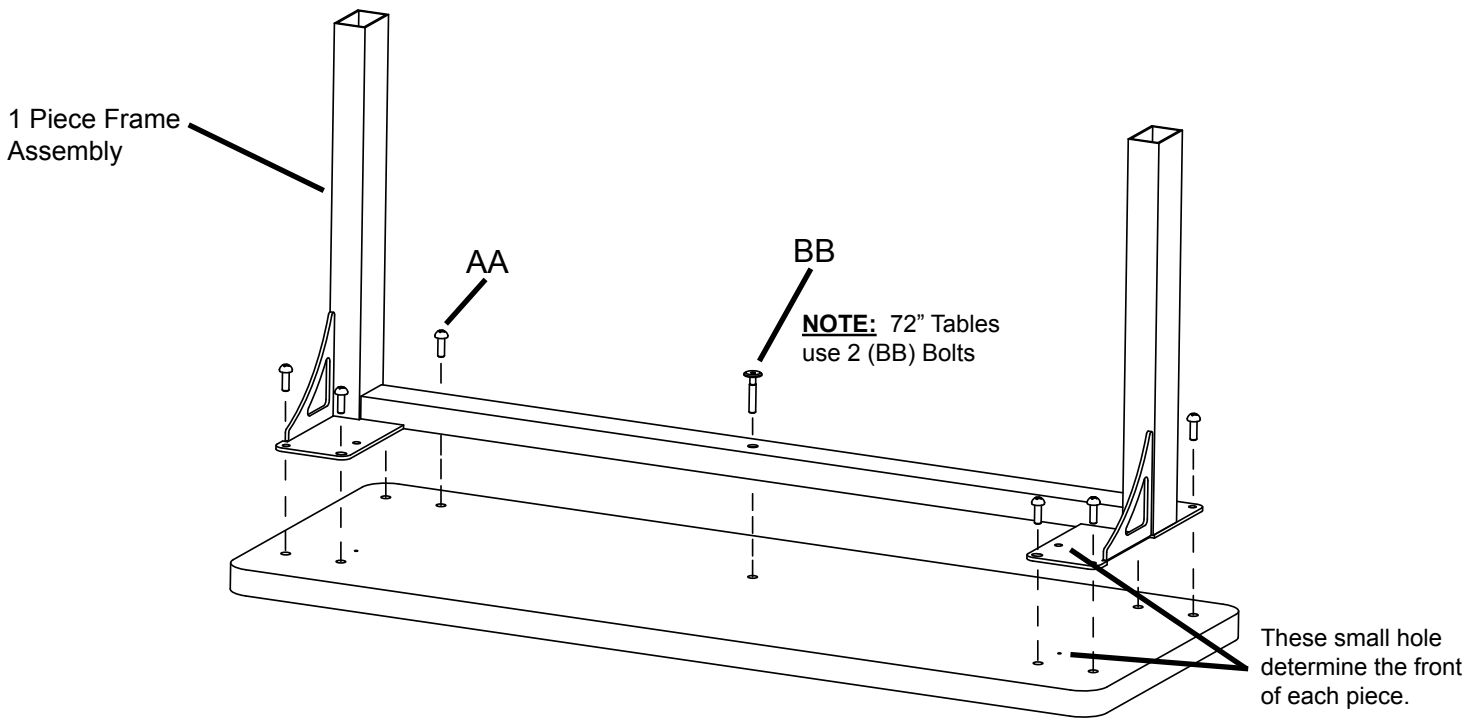

STEP 1

Lay the front top on carpeted surface with the holes facing up. **The front top is the 13"D piece.** Position the **one piece frame** assembly onto the top and attach with screws (AA) and connector bolt (BB). The leg holes in the frame assembly SHOULD face the back edge of the top. All holes on both pieces do line up. If they do not re-position both pieces and make sure both pieces face the front like shown in the figure above.

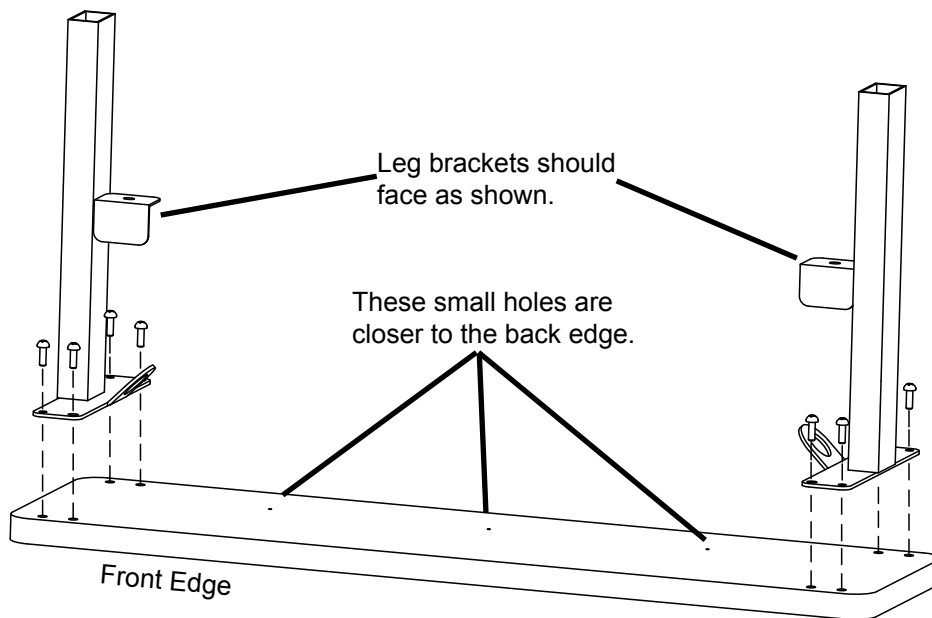

STEP 2

Lay the rear top on a carpeted surface with holes facing up. **The rear top will always be either 9 1/2"D or 15 1/2"D depending on overall size of your table.** Position the right and left upper legs as shown. Attach with screws (AA).

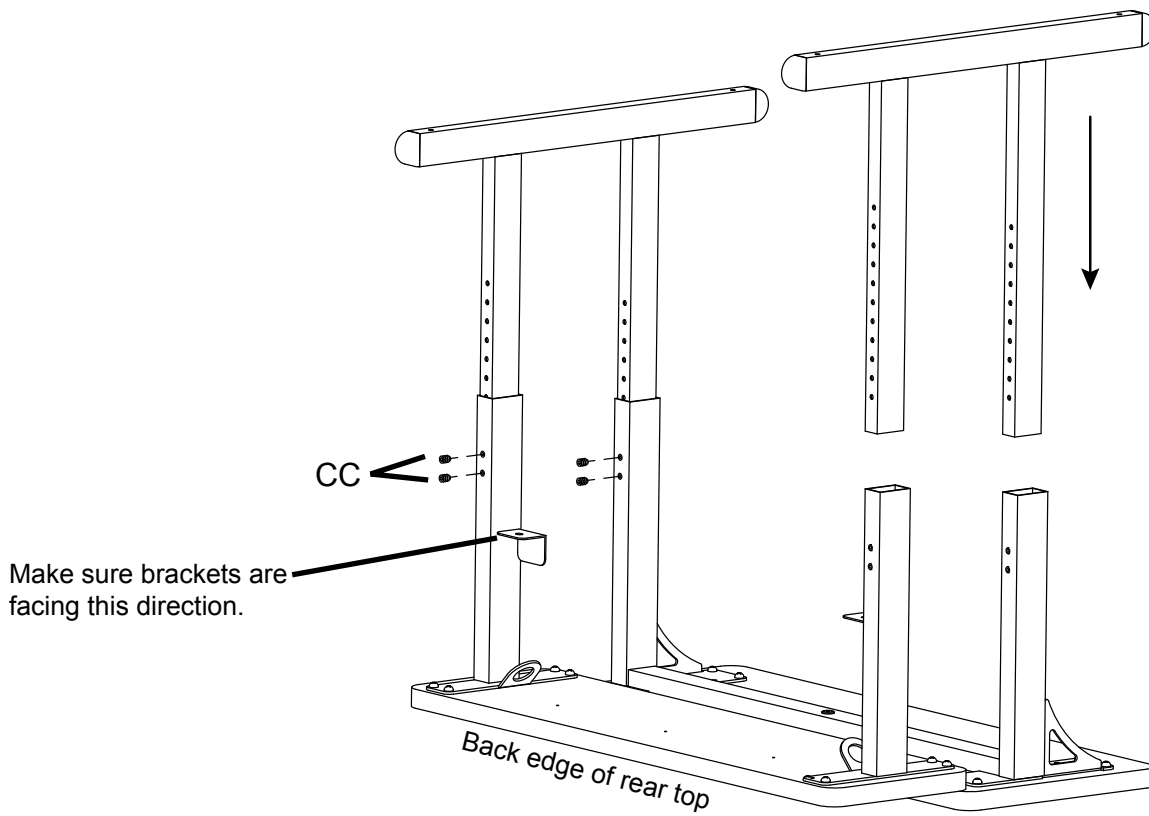

STEP 3

Set desired height of legs and insert set screws (CC) into legs and tighten with Allen wrench provided.

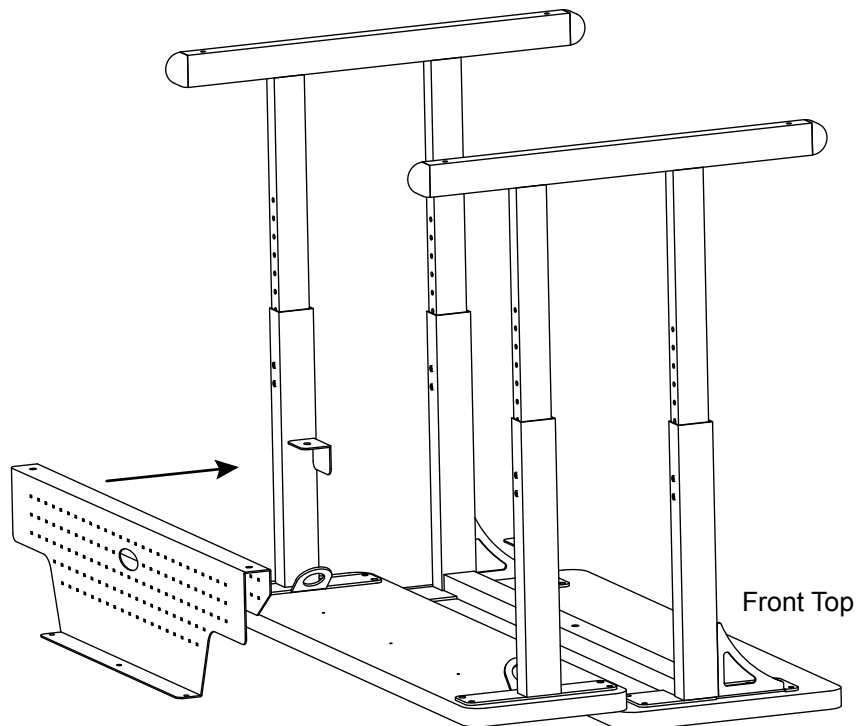

STEP 4

Slide modesty panel between the upper legs on the rear top as shown.

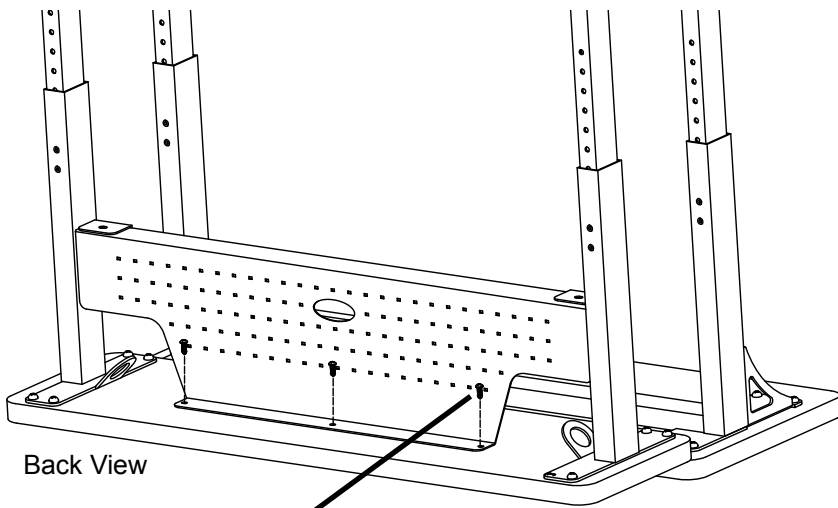

Back View

DD **FIGURE 1**

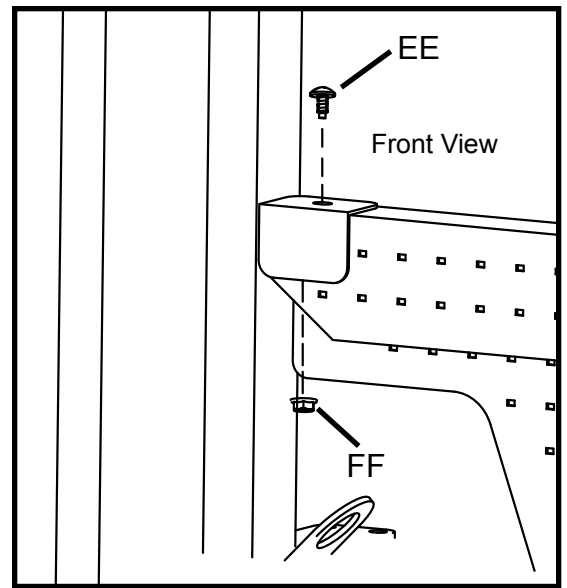

EE
Front View

FF

FIGURE 2

STEP 5

Attach modesty panel to rear top using screws (DD) as shown in **FIGURE 1**. From the front, attach the modesty panel to the upper legs using screws (EE) and nuts (FF) as shown in **FIGURE 2**.



DD

EE

FF

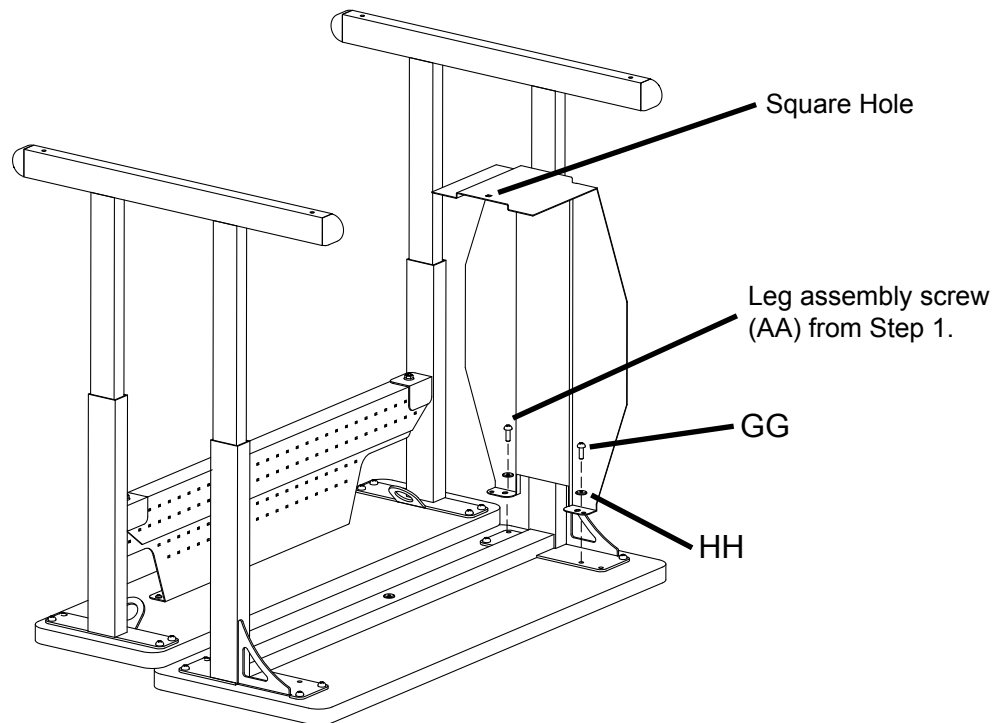

Square Hole

Leg assembly screw (AA) from Step 1.

GG

HH

STEP 6

Attach the CPU bracket with the square hole located on the bottom flange first. **NOTE:** The bracket will line up over one of the frame assembly holes. Take the screw out and replace it through the CPU bracket with washer (HH). Secure the other hole in the CPU bracket with washer (HH) and screw (GG) as shown.



GG

HH

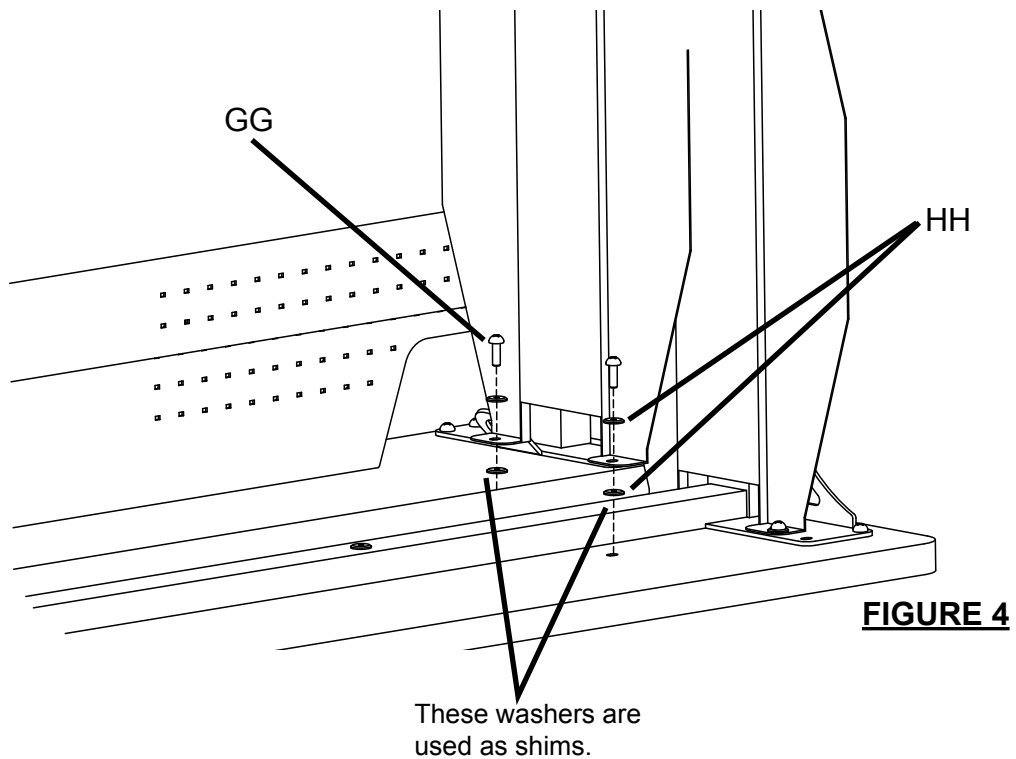
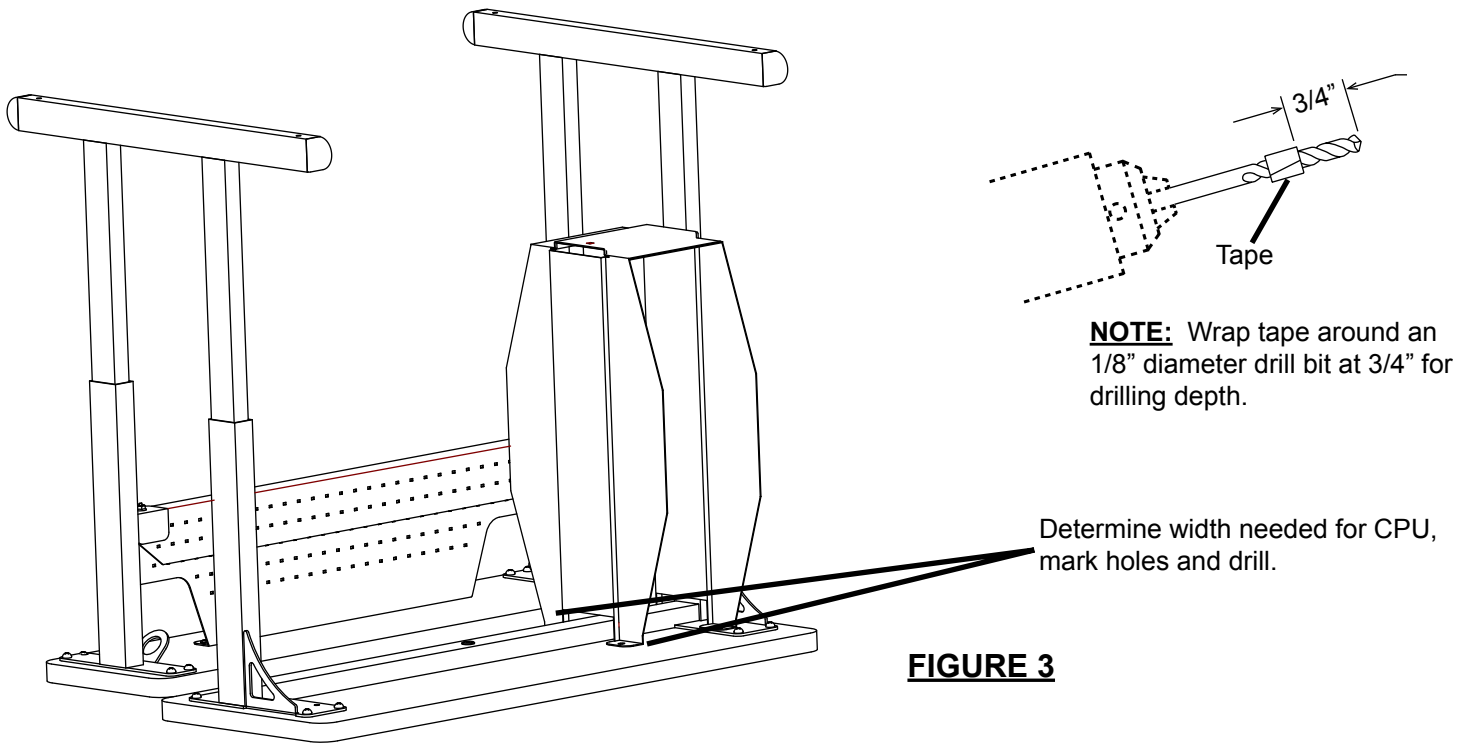

STEP 7

Determine the overall width of your CPU. Place the other CPU bracket under the mounted CPU bracket as shown. Adjust the space between the two brackets by sliding the bracket side to side to equal your CPU width. **MAKE SURE THAT THE BRACKETS ARE PARALLEL.** Using the CPU bracket as a template, mark the two hole locations for drilling pilot holes. Carefully drill an 1/8" dia. pilot holes 3/4" deep. **FIGURE 3.** Install the second bracket with screws (GG) and washers (HH) as shown in **FIGURE 4.** The washers that go between the wood top and CPU bracket are used as a shim to keep the CPU holder level.

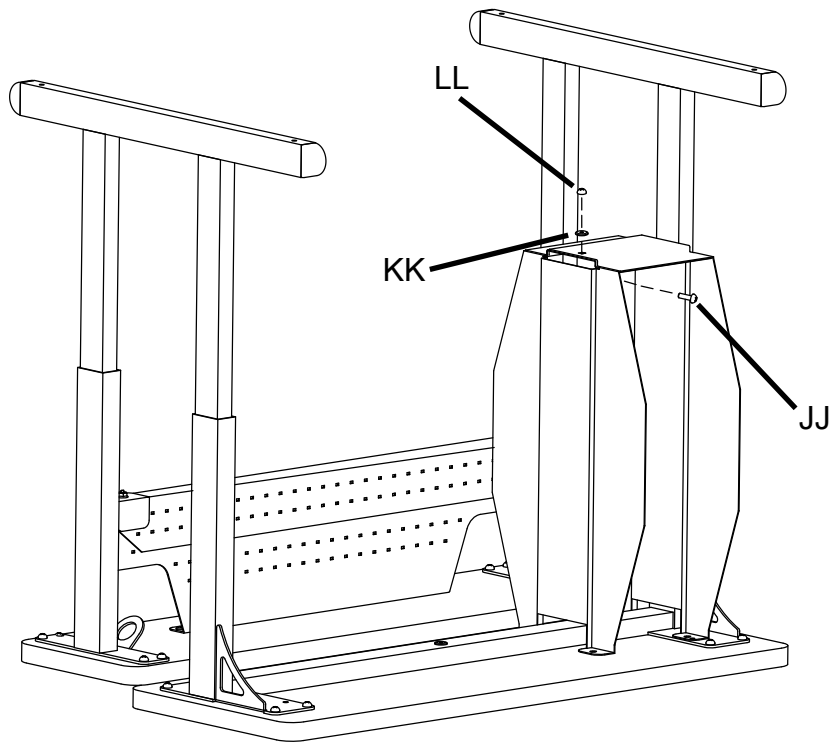

STEP 8

From inside the CPU holder insert carriage bolt (JJ) and secure in place with washer (KK) and nut (LL) on the outside as shown. **For attaching additional CPU holder for models 35FS65 and 35FS67, repeat steps 6, 7 and 8.**

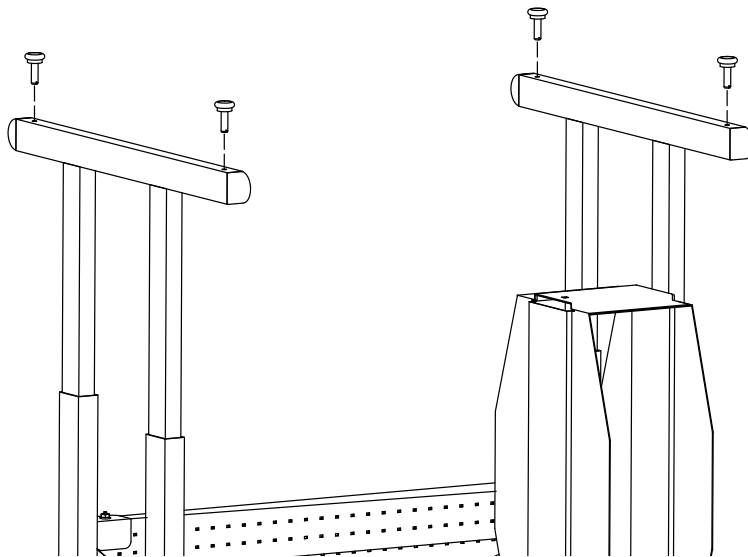
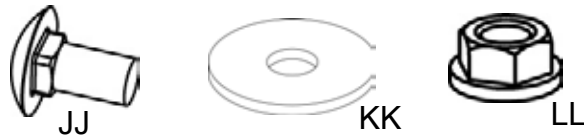

STEP 9

Install glides (II) into the bottom of each leg assembly as shown. Carefully turn table over, place into position and adjust glides if necessary.

Bretford
 11000 Seymour Avenue
 Franklin Park, IL 60131
 TEL: 847.678.2545
 800.521.9614
 FAX: 847.678.0852
 800.343.1779

Bretford Ltd.
 2 Etongate
 110 Windsor Road, Slough
 Berkshire SL1 2JA England
 TEL: 011 44 17 5353 9955
 FAX: 011 44 17 5353 9478