



BRETFORD

MULTIMEDIA WORKSTATION

UCS880

Assembly Instructions

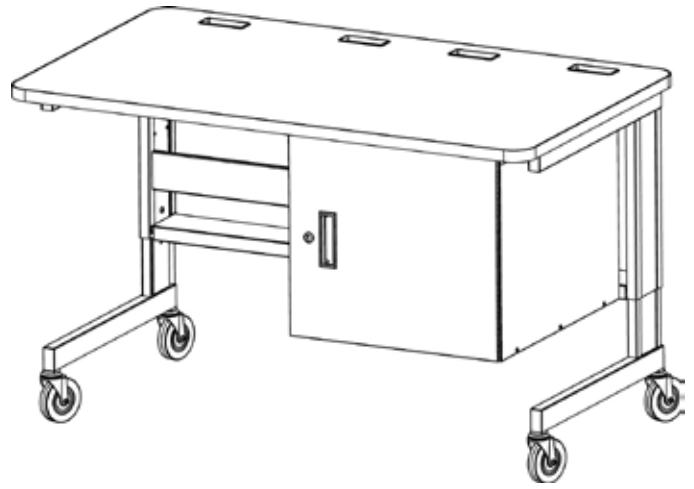

Parts List

Qty	Part #	Description
1	SA7747	Wood Top w/ 4 Plastic Grommets (012-0616)
1	010-2244	Modesty Panel
1	010-2246	Modesty Panel Shelf
1	022-2759	Cabinet Left Side Panel w/Magnet (030-0186)
1	022-2760	Cabinet Right Side Panel
1	010-2250	Cabinet Bottom Shelf
1	010-2467	Access Door Panel
1	022-1385	Right Upper Outer Pedestal Assembly
1	022-1386	Right Lower Inner Pedestal Assembly
1	022-1387	Left Upper Outer Pedestal Assembly
1	022-1388	Left Lower Inner Pedestal Assembly
1	022-2761	Cabinet Door Assembly
1Pr.	030-1337	Rack Rail
2	010-4867	Cabinet Rack Shelf

Hardware List

Ref	Qty	Part #	Description
AA	14	030-0325	1/4-20 x 1/2" Combo Truss Screws
BB	16	030-0304	1/4-20 x 5/8" Combo Truss Screws
CC	12	030-0240	1/4" External Lock Washers
DD	3	030-0255	#10 x 5/8" Phillips Pan Head Screws
EE	14	030-0402	#10-32 x 5/8" Black Combo Screws
FF	10	030-0291	#10-32 x 1/2" Phillips Truss Screws
GG	7	030-0357	10-32 Flanged Hex Serrated Nuts
HH	3	030-0716	1/4-20 x 1/2" Pin Hex Security Screws
II	3	030-0465	Fiber Washers
JJ	1	012-0286	Door Handle
KK	2	030-0259	#10 x 1/2" Phillips Pan Head Screws
LL	3	030-1450	#10-32 Weld Nuts, Zinc Coated
MM	2	015-0011	1/2" Rubber Bumpers
NN	4	030-1338	1/4-20 J-Nut
	2	030-0717	5/32" Hex Drive Bit
	2	015-0002	4" Casters w/o Lock - Rear
	2	015-0003	4" Casters w/ Lock - Front
	1		Set of Keys

Tools Required

- Phillips Screwdriver (Magnetic)
- Flat Screwdriver
- 1/4" Nut Driver/Socket

NOTE: Height adjustment dimensions listed, include 4 1/2" for casters.

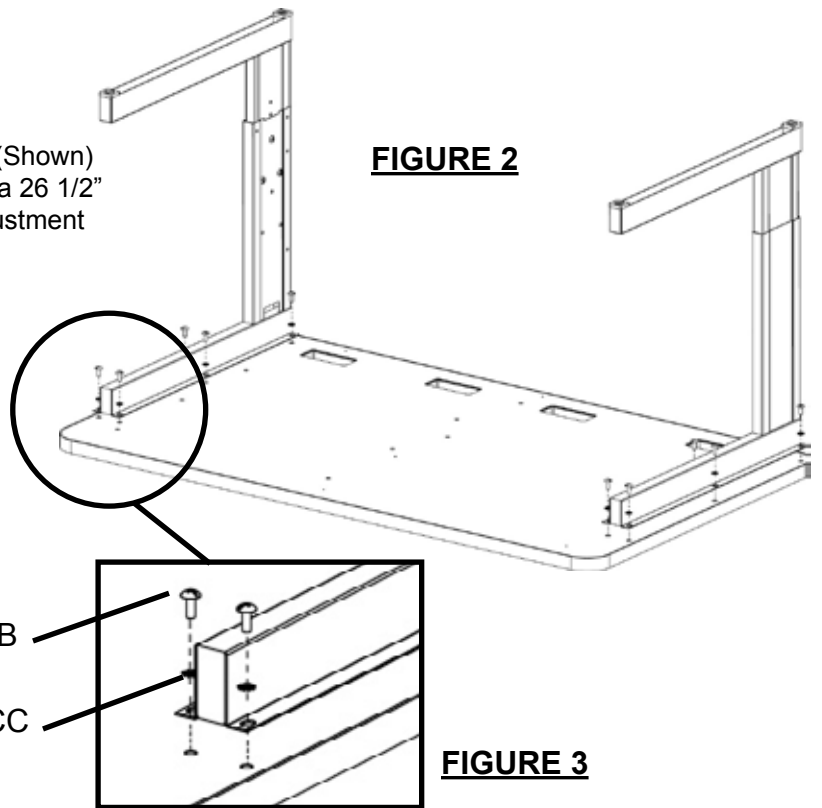
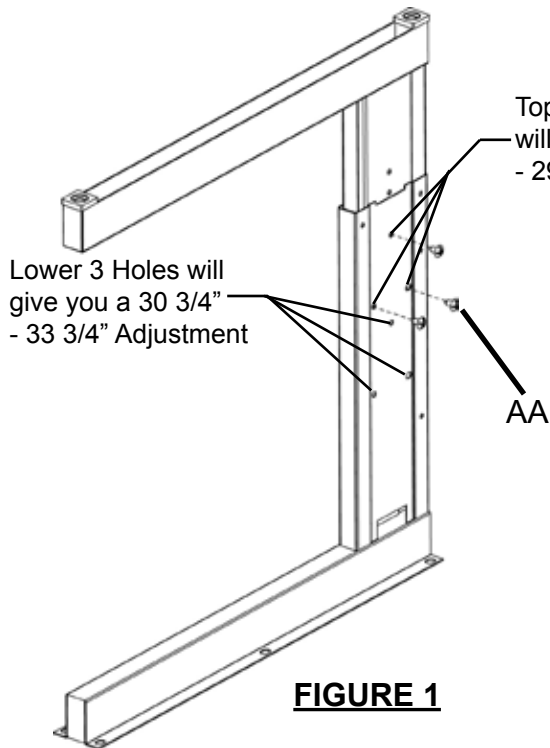

STEP 1

The upper and lower legs are shipped assembled. Remove and discard the screw holding them in place. Determine your table height. Reference **FIGURE 1**. Secure upper and lower legs with screws (AA). Lay wood top on a clean flat surface with holes facing up (top of carton works well). Position legs with holes facing inward (**FIGURE 2**). **LOOSELY** attach with screws (BB) and washers (CC) as shown in **FIGURE 3**.

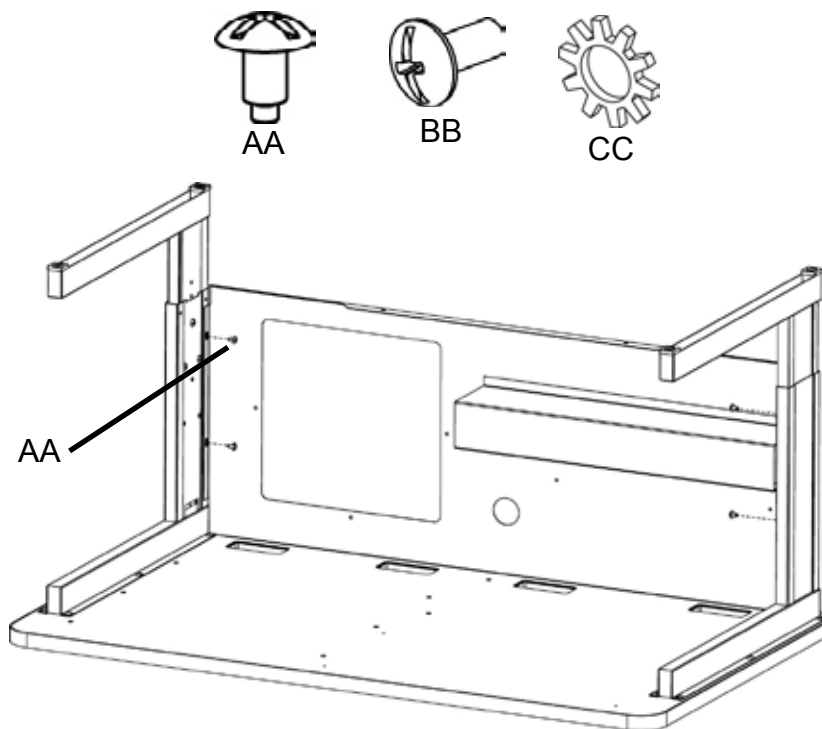

Loosely attach modesty panel between the legs with screws (AA) as shown.

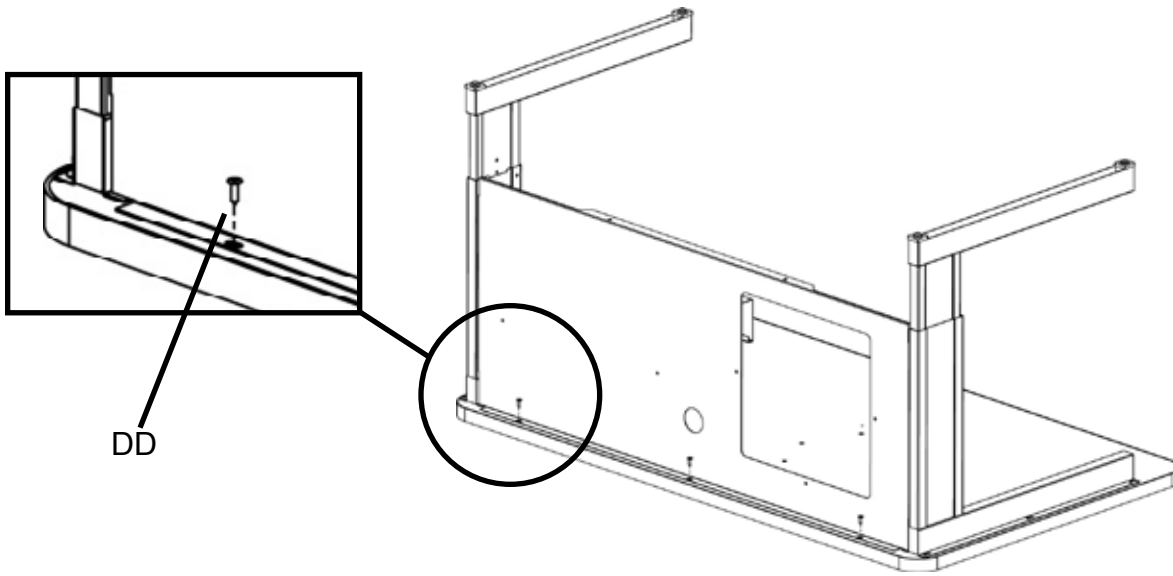

STEP 3

From behind attach modesty panel to wood top with screws (DD) as shown. **TIGHTEN ALL HARDWARE AT THIS TIME.**



FIGURE 4

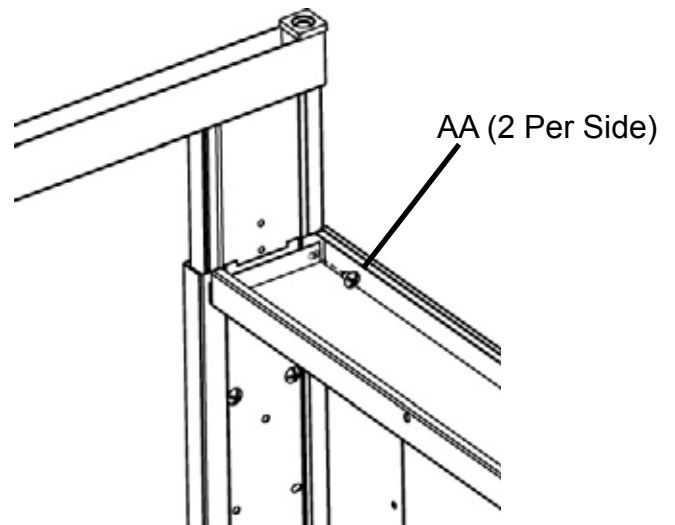
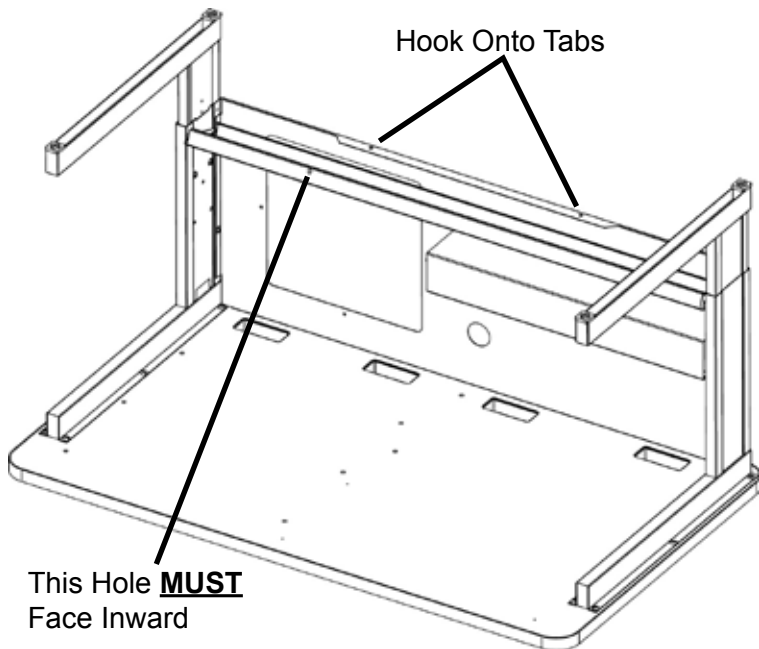
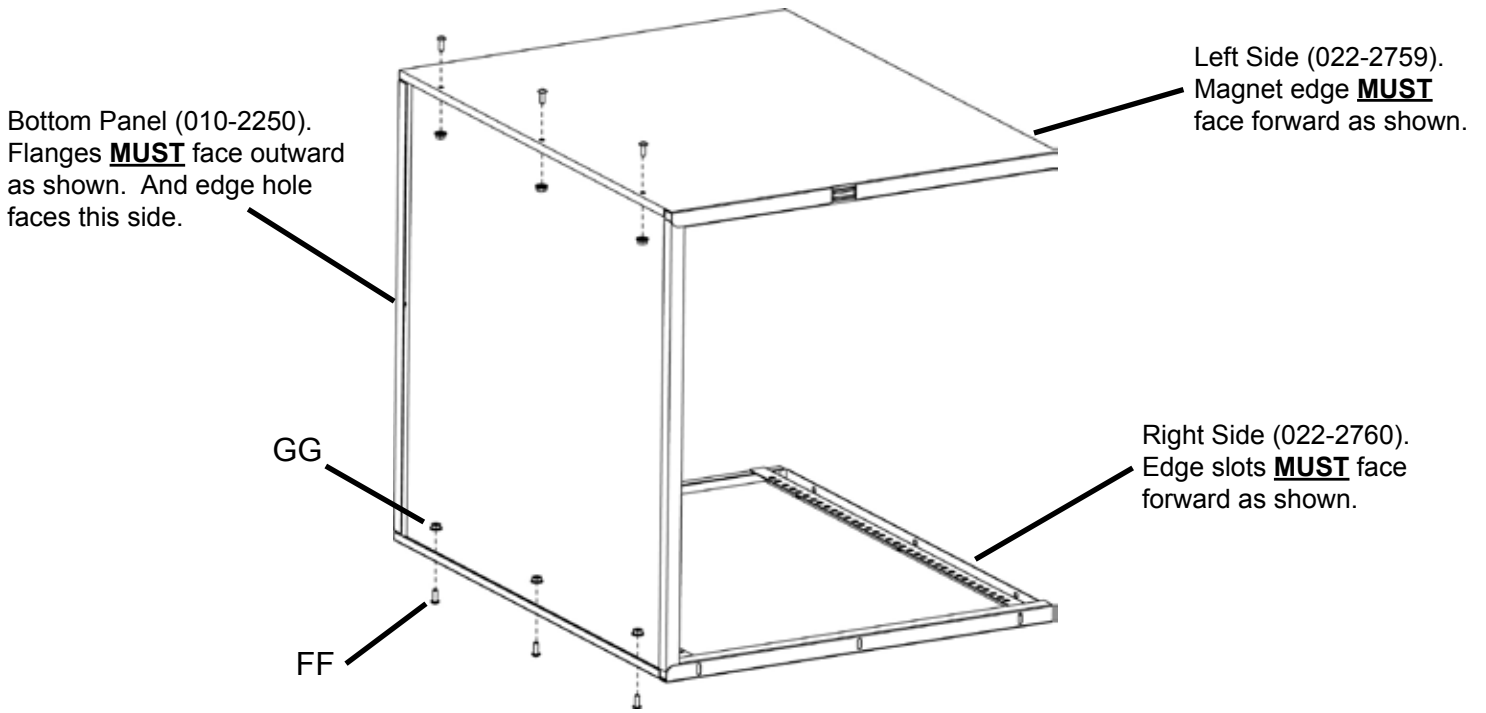

FIGURE 5

STEP 4

Tilt modesty panel shelf with flanges facing upward; hook onto tabs in modesty panel (**FIGURE 4**). **NOTE:** It may be necessary to open the tabs up a bit with a flat screwdriver. Attach at corners with screws (AA) as shown in **FIGURE 5.**



STEP 5

Assemble cabinet by standing the bottom shelf on its side with flanges facing out; attach right & left side panels with screws (FF) and nuts (GG). **Make sure all panels are positioned as indicate above.**

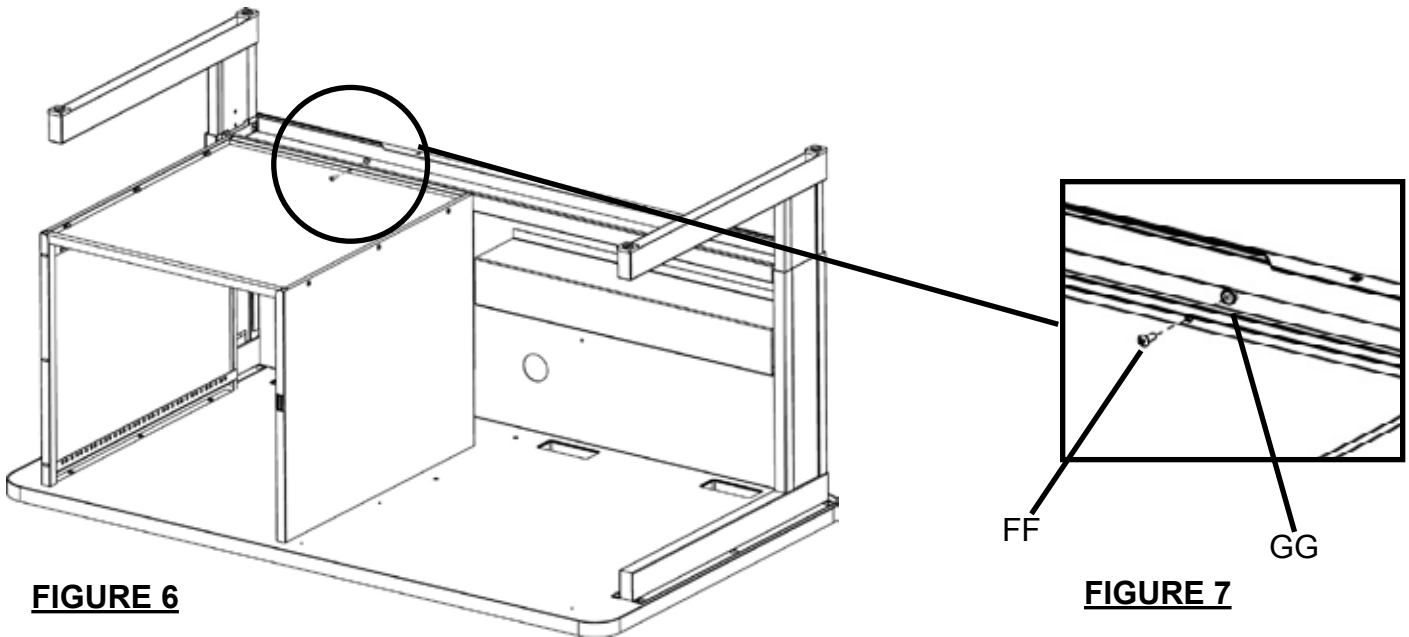

STEP 6

Position cabinet onto unit with holes in bottom shelf and modesty panel shelf lining up (**FIGURE 6**). Secure through hole with screw (FF) and nut (GG) as shown in **FIGURE 7**.

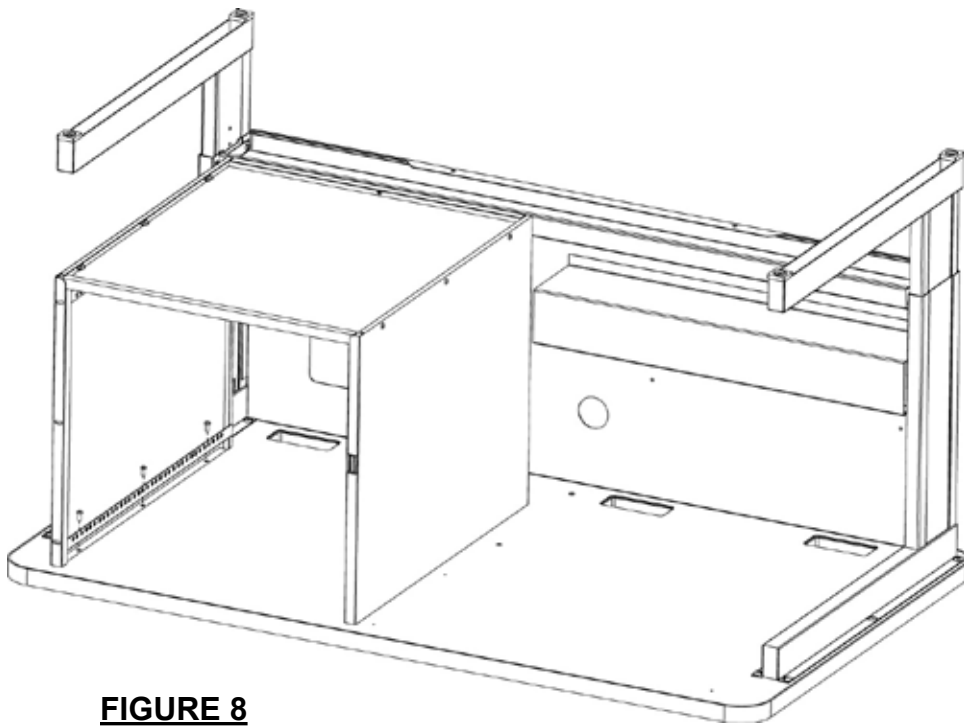

FIGURE 8

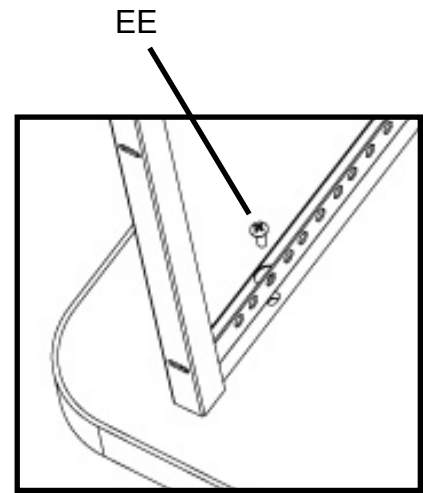
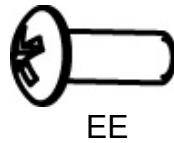

FIGURE 9

STEP 7

Secure cabinet sides to wood top using screws (EE) as shown in **FIGURE 8**. **FIGURE 9** shows the clearance hole for the screw to pass through when attaching to the top.



EE

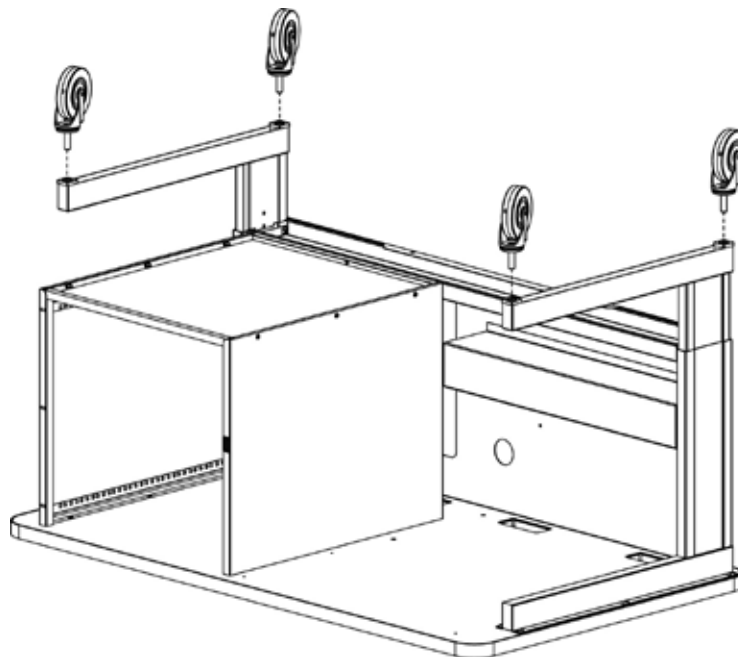

STEP 8

Insert casters into legs. **NOTE:** Casters should be pushed completely into the legs so that the entire stem is inside. Turn unit upright.

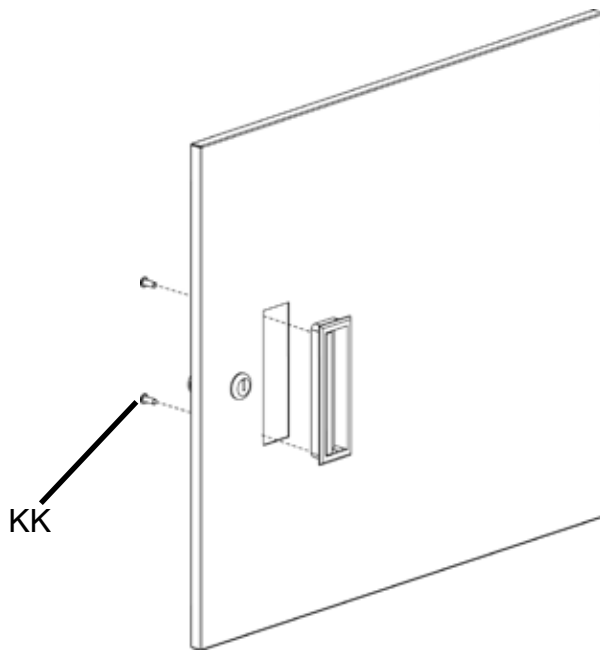

STEP 9

Attach handle (JJ) with screws (KK) as shown.

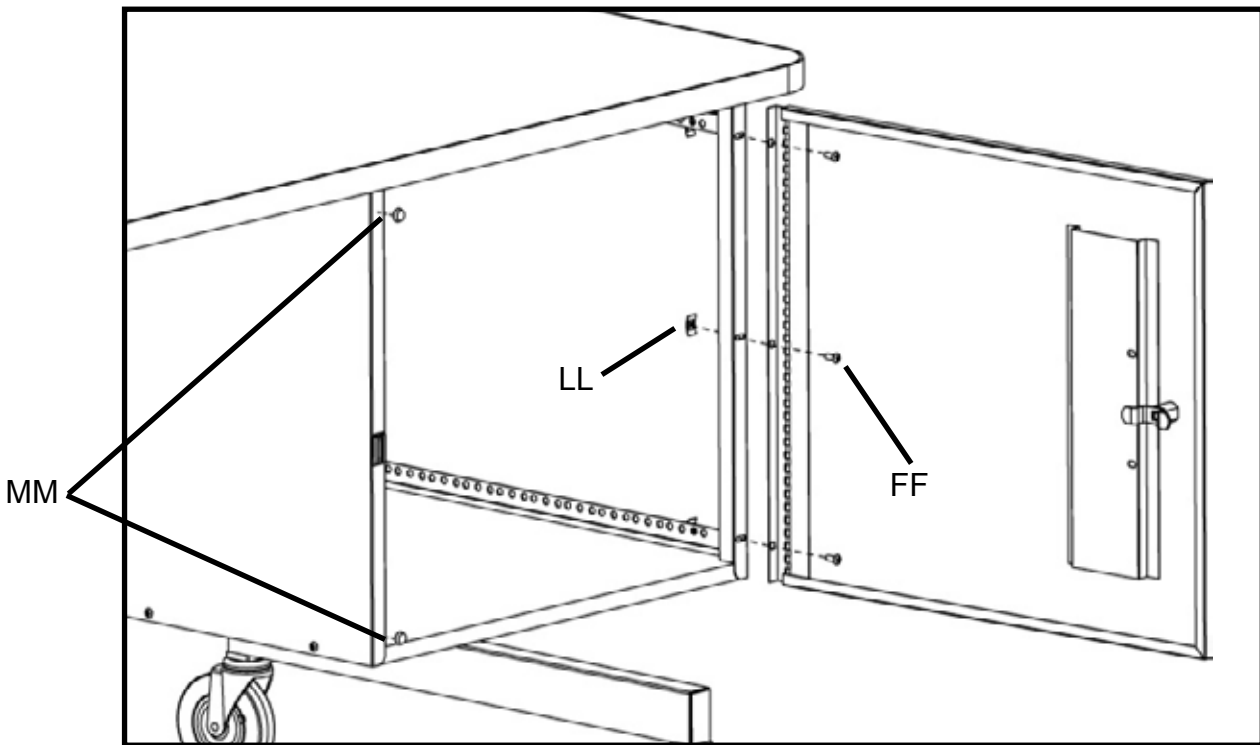
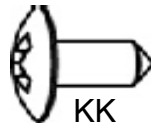

STEP 10

Attach door to right side panel using nuts (LL) and screws (FF) as shown. Stick on bumpers (MM) near the top and bottom of left side panel as shown.



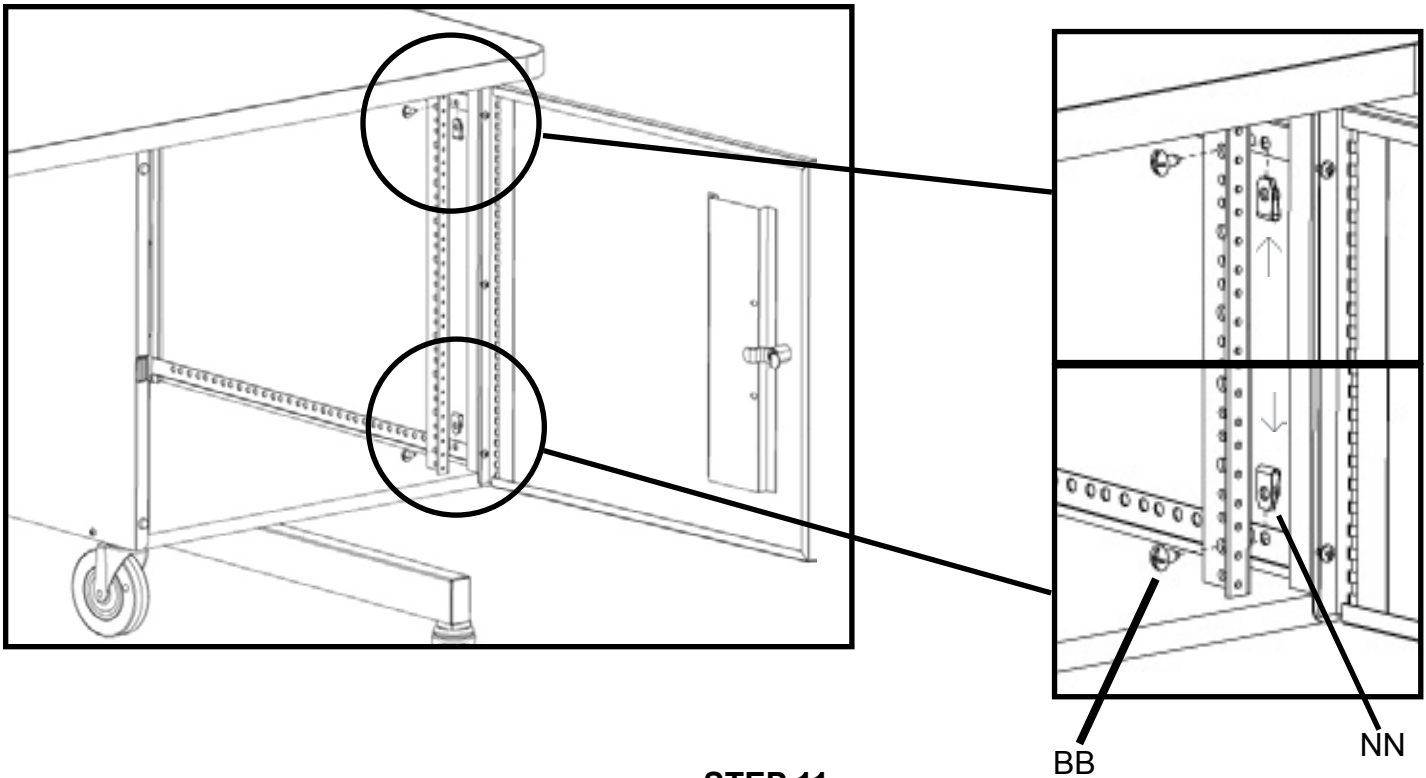

STEP 11

Attach rack rails inside cabinet using screws (BB) and nuts (NN) as shown.



NN

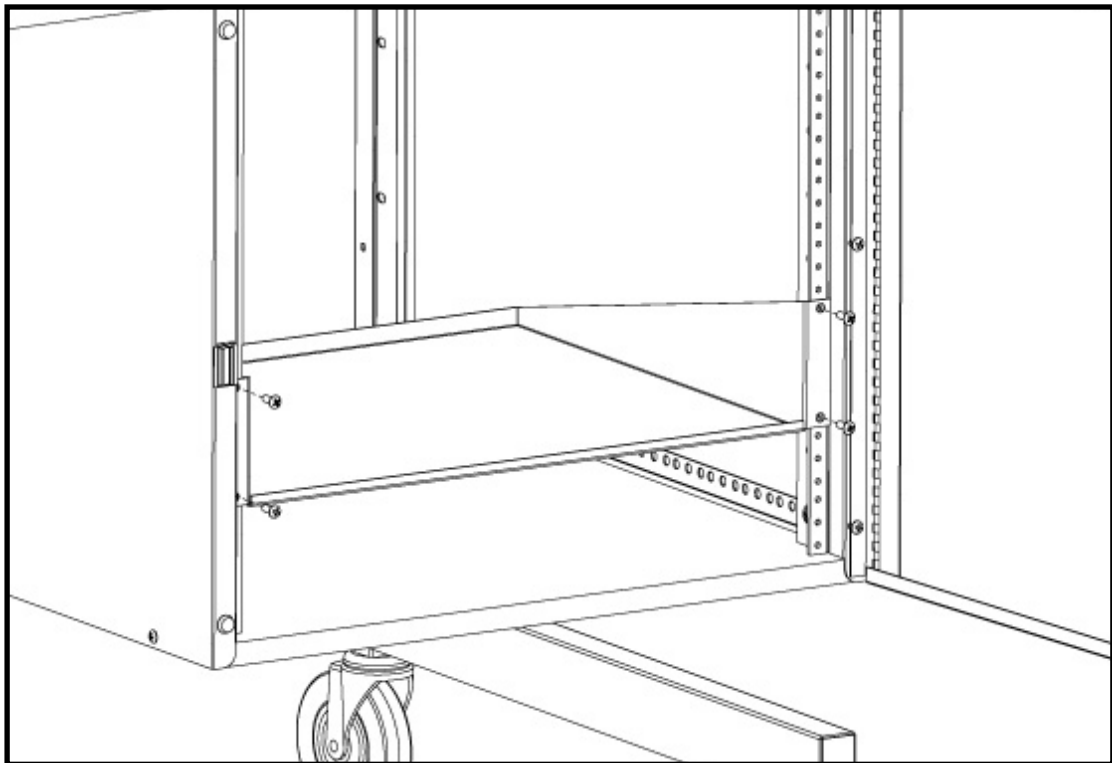

STEP 12

Attach rack shelves onto the rack rails at your desired location with screws (EE) as shown. Now install your rack mount electronic equipment.

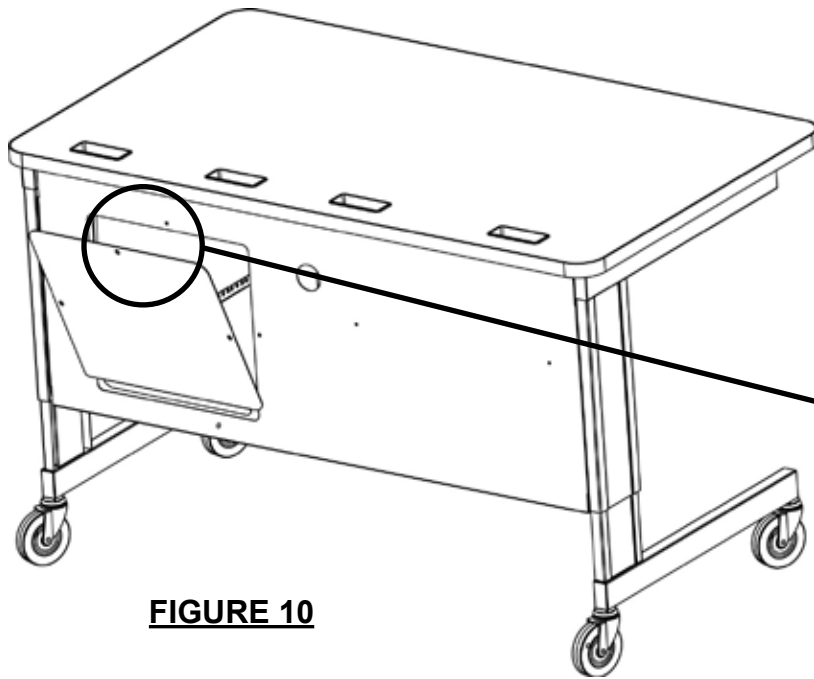
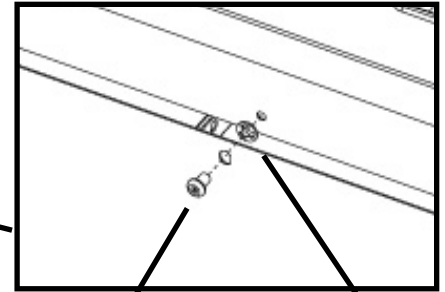

FIGURE 10



HH

II

FIGURE 11

STEP 13

Attach access door from behind the unit as shown in **FIGURE 10**. **NOTE:** The access door is meant for easy access to wires/cables of your component pieces. Attach access door using security screws (HH) and washers (II) as shown in FIGURE 11. Washers should be positioned between door and modesty panel. Tighten all screws (HH) with pin-in-head Allen (provided) using a 1/4" nut driver/socket.



HH



II



Bretford
11000 Seymour Avenue
Franklin Park, IL 60131
TEL: 847.678.2545
800.521.9614
FAX: 847.678.0852
800.343.1779

Bretford Ltd.
2 Etongate
110 Windsor Road, Slough
Berkshire SL1 2JA England
TEL: 011 44 17 5353 9955
FAX: 011 44 17 5353 9478