

Technology Table Bridge Pack

PARTS and HARDWARE LIST

REF	QTY	DESCRIPTION
	1	Bridge Bracket
	2	Ganging Plate
	1	30-0325 Screws

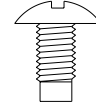

STEP 1

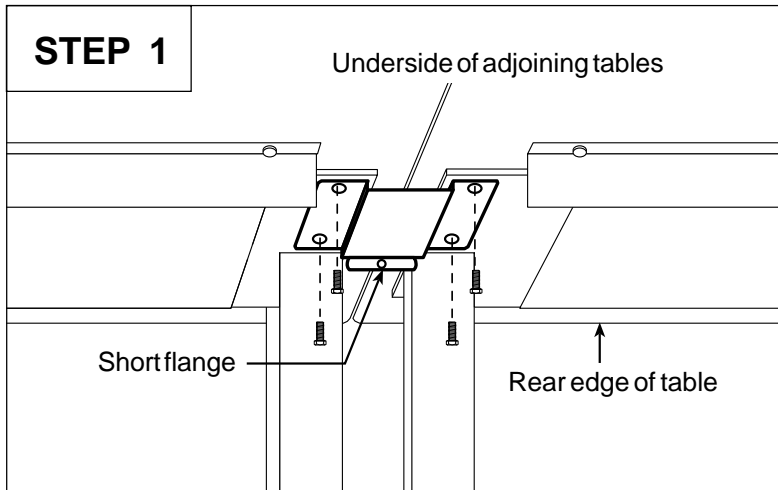

Position tables next to each other.

NOTE: The adjacent edges of the tables to be bridged must NOT have end caps on the Wire Management Bin.

Remove outer bolts from leg plate (parallel with and closest to common edge) of both front and back legs. Position Ganging Plate over Leg Plate holes, with the short flange facing the rear of the table. Attach Ganging Plate by replacing the bolts.

NOTE: For 39" Technology Tables you will have to remove the Front Leg Stiffener from one of the tables.

STEP 2

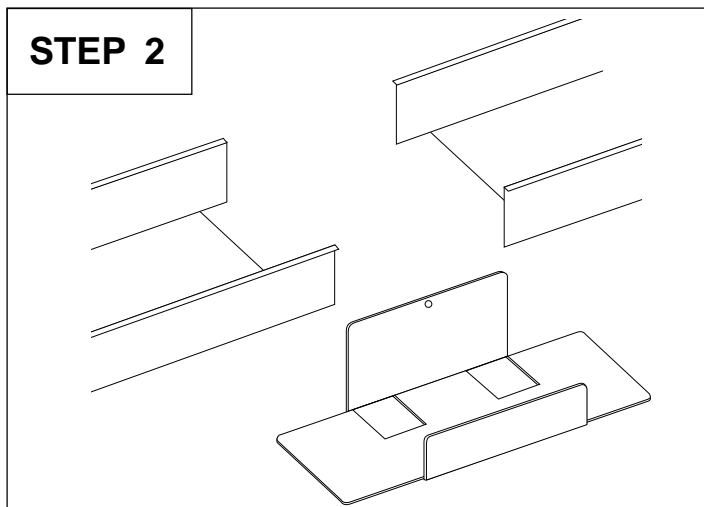

Note: The Table Worksurface and Legs are not shown for clarity in steps 2 thru 6.

Prepare to place the bridge into the cord bins.

STEP 3

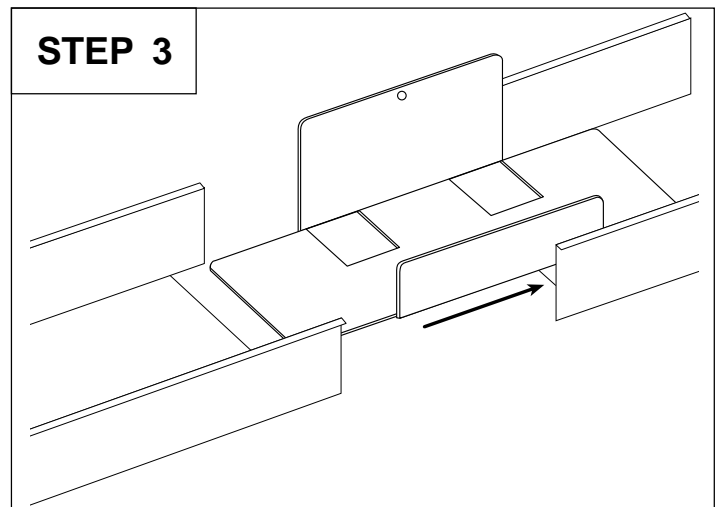

Place bridge into both bins. Slide bridge all the way into one bin, in order to get both ends of the bridge up into the bins.

STEP 4

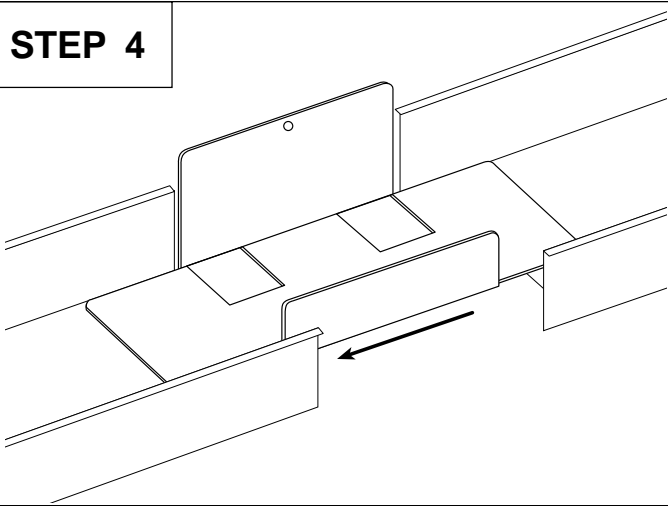

Slide the bridge back into proper position, between the two bins.

STEP 5

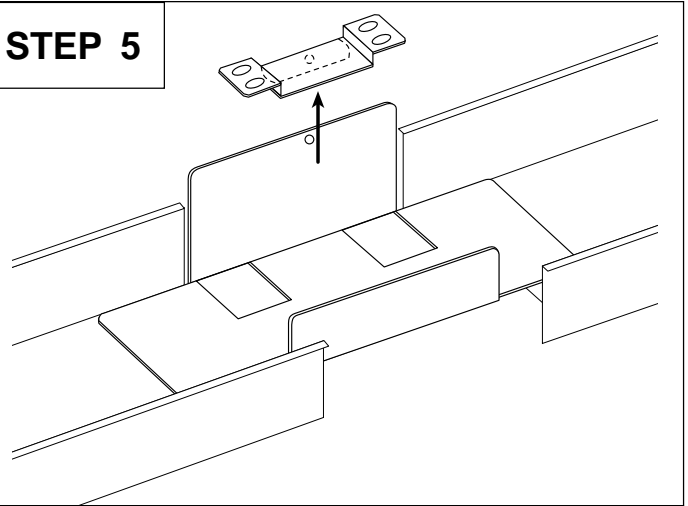

Make sure pre-drilled hole in bridge aligns with hole in flange of ganging plate, and that both ends are positioned **INSIDE** bins.

STEP 6

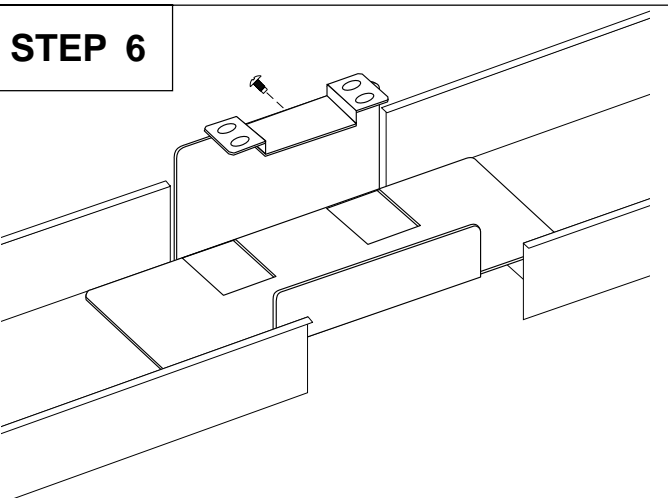

Assemble Bridge Bracket, fitting the bridge **IN FRONT** of the ganging plate flange.

Secure with 30-0325 screw.

Bretford
11000 Seymour Avenue
Franklin Park, IL 60131
TEL: 847.678.2545
800.521.9614
FAX: 847.678.0852
800.343.1779

Bretford Ltd.
Technology House
7 Lake End Court, Taplow
Bucks SL6 0JQ England
TEL: 01628 603558
FAX: 01628 604923