

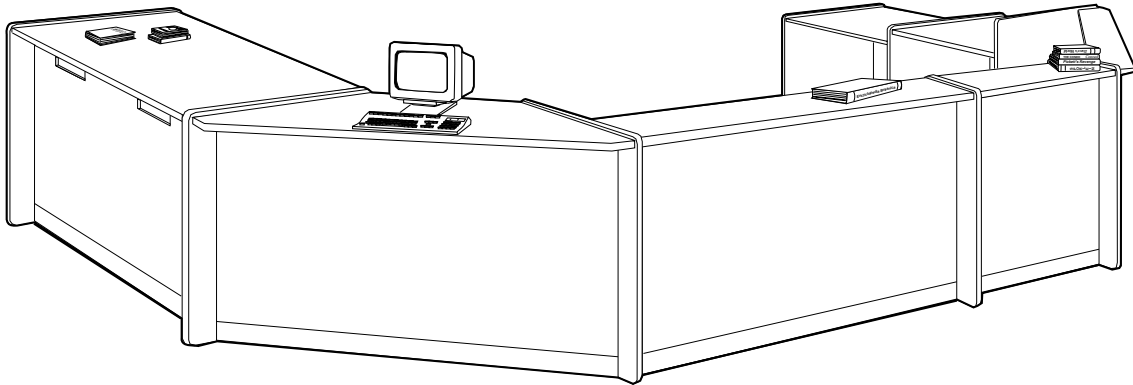

BRETFORD

LEGACY Circulation Desk Assembly Instructions



Caution: Make sure to measure the room for exact placement because you cannot move desk as a whole once assembled.

Please Refer to CAD Printout Enclosed for the Parts List and Specific Arrangement of Your LEGACY Circulation Desk.

General Guidelines for Proper Assembly

1. Review CAD floor plan for correct placement of each desk. Each end panel is numbered on the drawing and the piece itself has the corresponding number on the bottom edge. This should insure proper arrangement of your desks.
2. If you have a 90° corner connector in your arrangement, you **MUST** assemble it **FIRST**. This unit cannot be assembled at any other time.
3. Find the high point in the area in which your circulation desk is to be located. Starting in this area will make leveling and assembling units easier.
4. Use CAD drawing and the following instructions to assemble. Match all hardware packs to CAD drawing.
5. After each component is finished make sure the unit is level in both width and depth.

Table of Contents

90° Corner Connector Assembly	p 2
Rectangle Worksurface Assembly	p 8
Book Drop Installation	p 10
Trapezoid Worksurface Assembly	p 11
Transaction Counter Assembly	p 13

**For More Information On The
LEGACY LIBRARY COLLECTION
Call Toll-Free 1-800-521-9614**

LEGACY CIRCULATION DESK

90° Corner Connectors

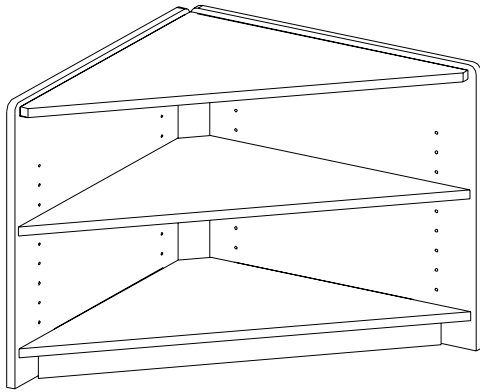

OPEN CORNER CONNECTOR ASSEMBLY INSTRUCTIONS

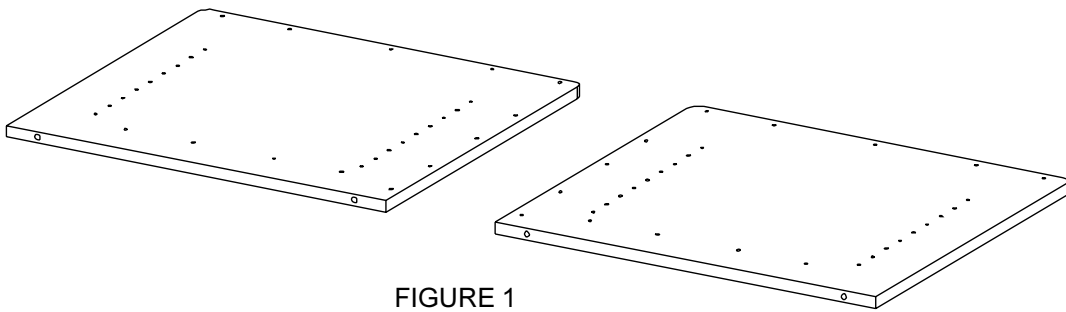

FIGURE 1

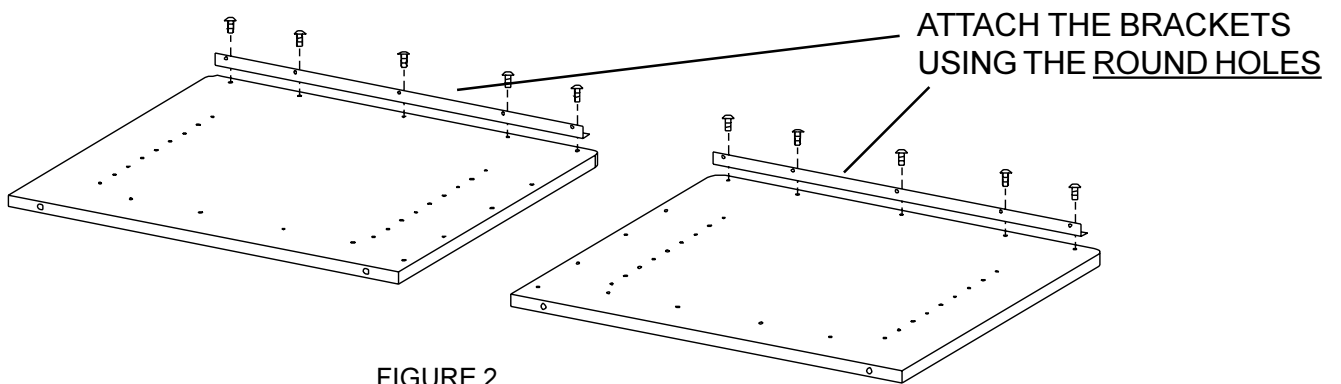
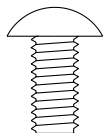
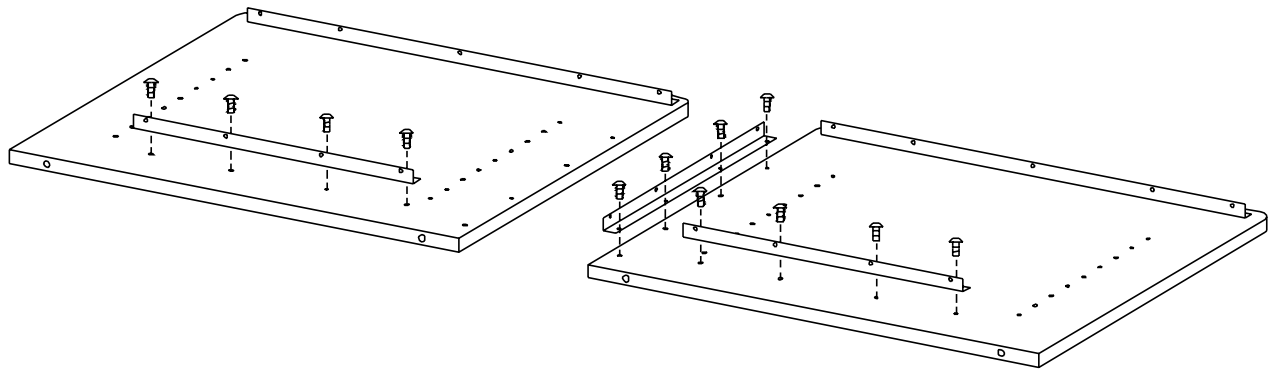

FIGURE 2

STEP 1

Locate the correct end panels for this unit and lay them down with holes facing up as shown in **FIGURE 1**. Attach the 2 longer support brackets to the top of each end panel using the 1/4-20 x 1/2" machine screws as shown in **FIGURE 2**.





STEP 2

Attach 2 of the shorter support brackets to the bottom of each end panel and 1 to the middle of one end panel as shown. Secure the brackets in place using the 1/4-20 x 1/2" machine screws as shown.

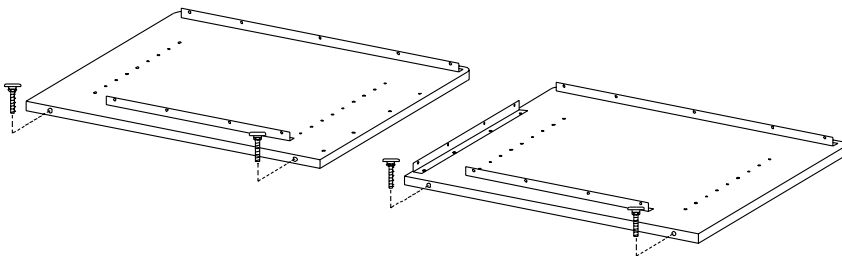

STEP 3

Twist the glides into the bottom of each end panel as shown.

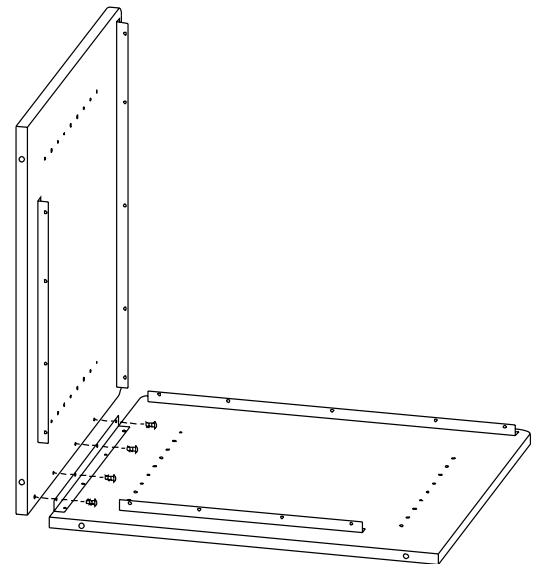

STEP 4

Secure the end panels together through the center bracket using the 1/4-20 x 1/2" machine screws as shown.

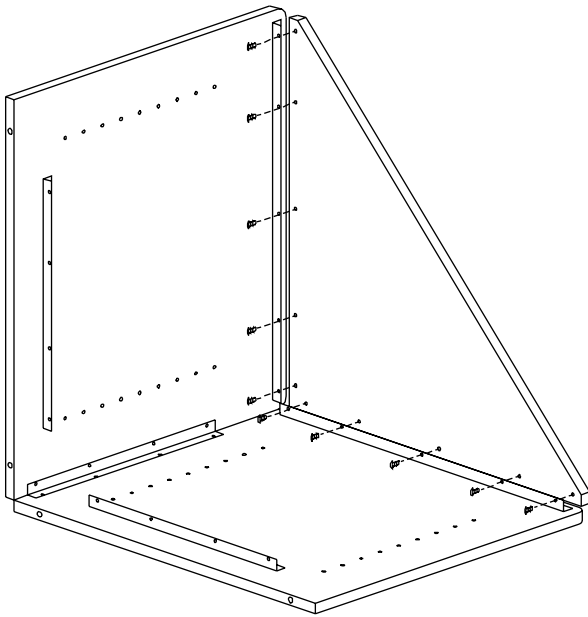

STEP 5

Secure the top shelf to the end panels through the top brackets using the 1/4-20 x 1/2" machine screws as shown.

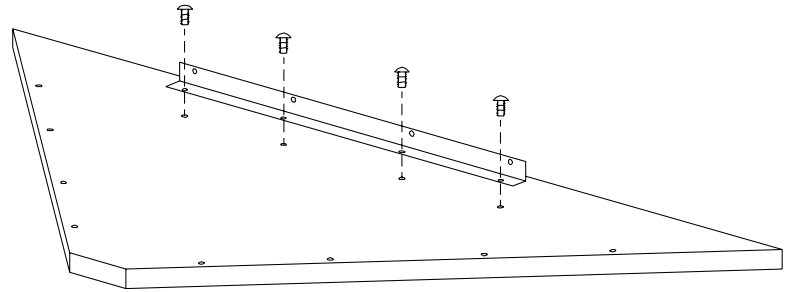

STEP 6

Lay the bottom shelf down with the holes facing up as shown. Attach a support bracket as shown using the 1/4-20 x 1/2" machine screws.

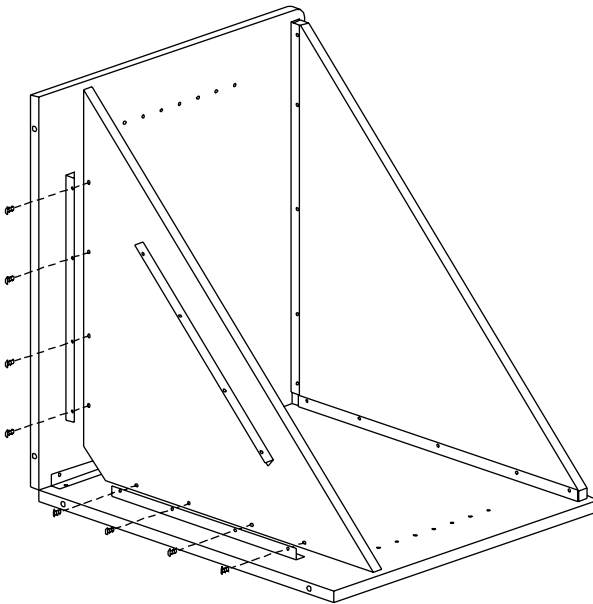

STEP 7

Secure the bottom shelf to the end panels through the brackets as shown using the 1/4-20 x 1/2" machine screws.

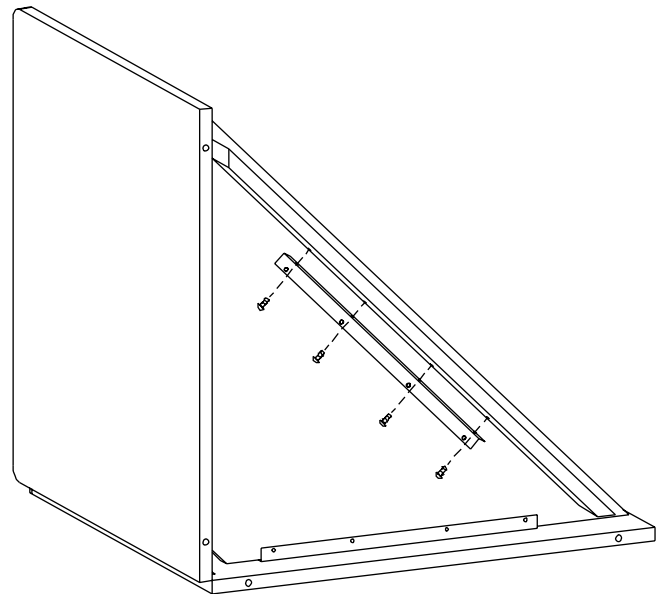

STEP 8

Fasten the toe kick to the bottom shelf through the bracket as shown using the 1/4-20 x 1/2" machine screws.

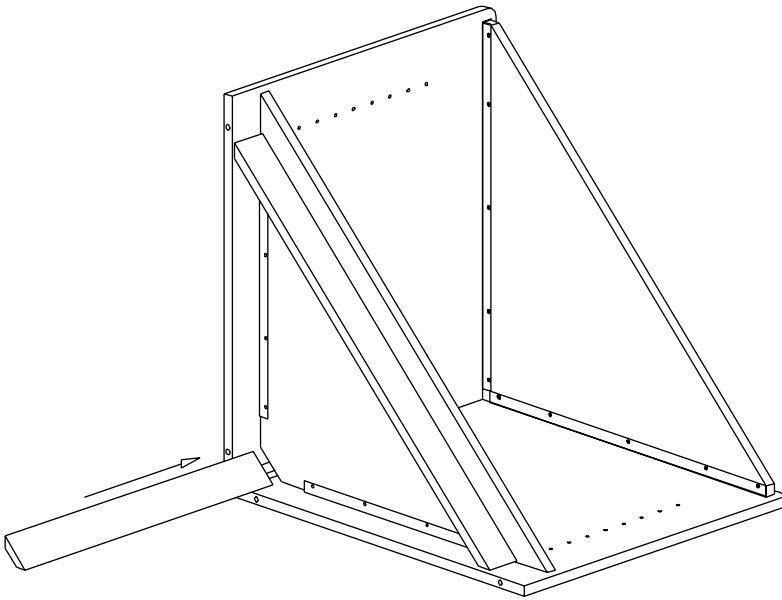

FIGURE 3

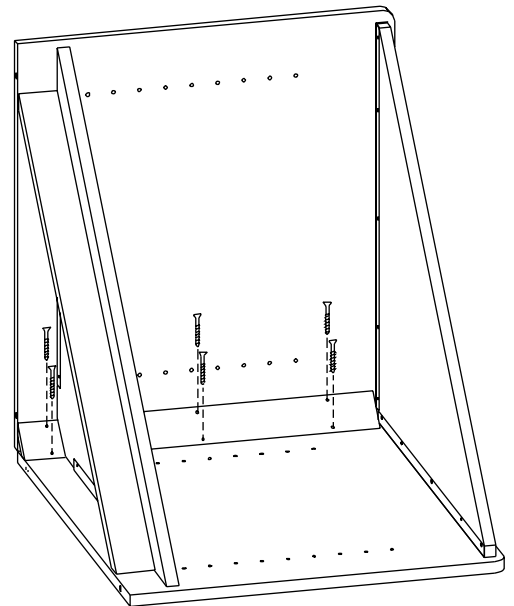
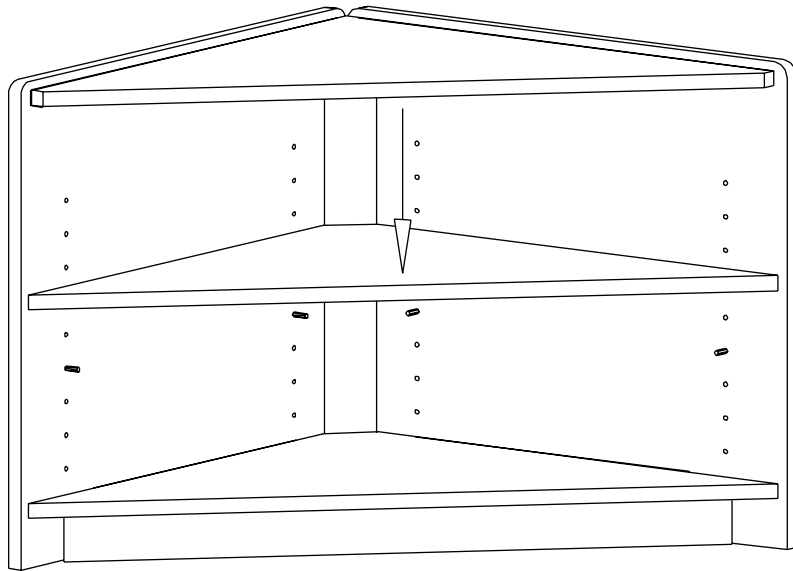
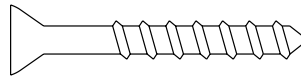

FIGURE 4

STEP 9

Slide the filler panel into the unit so that it is positioned in between the end panels and the shelves as shown in **FIGURE 3**. Secure in place with the #8 x 1 1/4" flat head screws as shown in **FIGURE 4**.



STEP 10

CAREFULLY stand unit upright. Insert the collar pins into the desired holes for the adjustable shelf location. Lower the adjustable shelf onto the collar pins.

IMPORTANT NOTE: Once unit is fully assembled, final position should be determined. The rest of your circulation desk assembly should be done off this unit. Once entire arrangement is assembled, it cannot be moved.

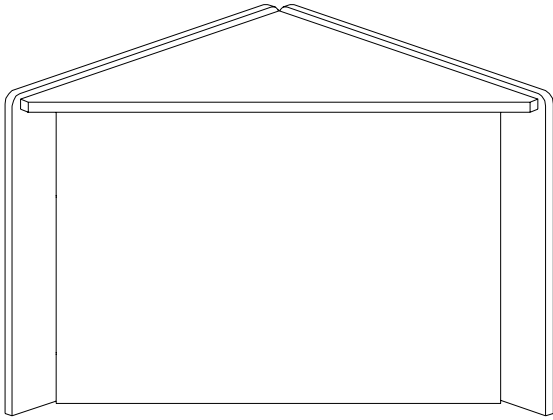

CLOSED CORNER CONNECTOR ASSEMBLY INSTRUCTIONS

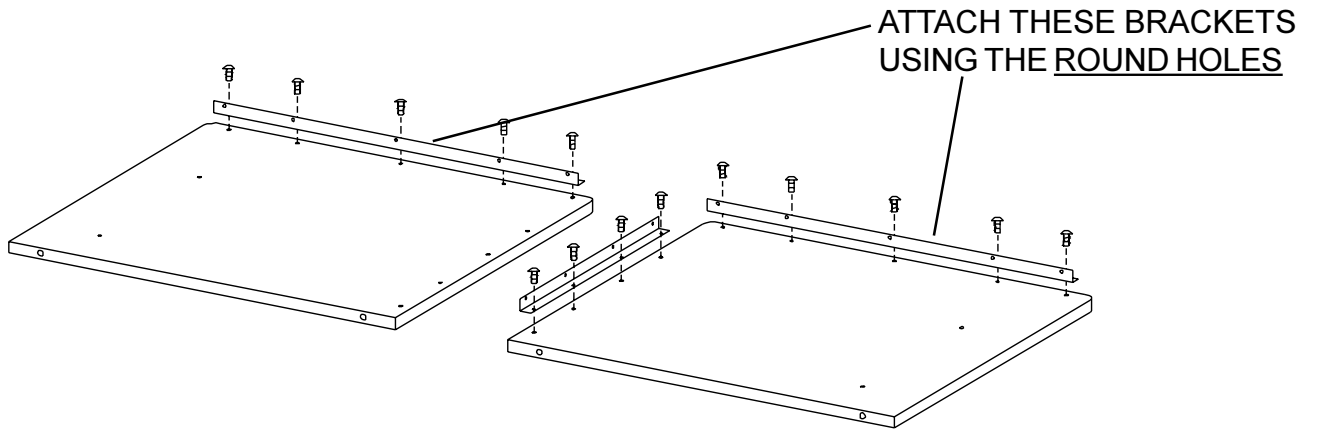

STEP 1

Lay the correct end panels down with holes facing up. Attach 2 of the longer support brackets to the top edge of each end panel and attach 1 smaller support bracket to the middle of one end panel as shown. Secure brackets in place using the 1/4-20 x 1/2" machine screws.

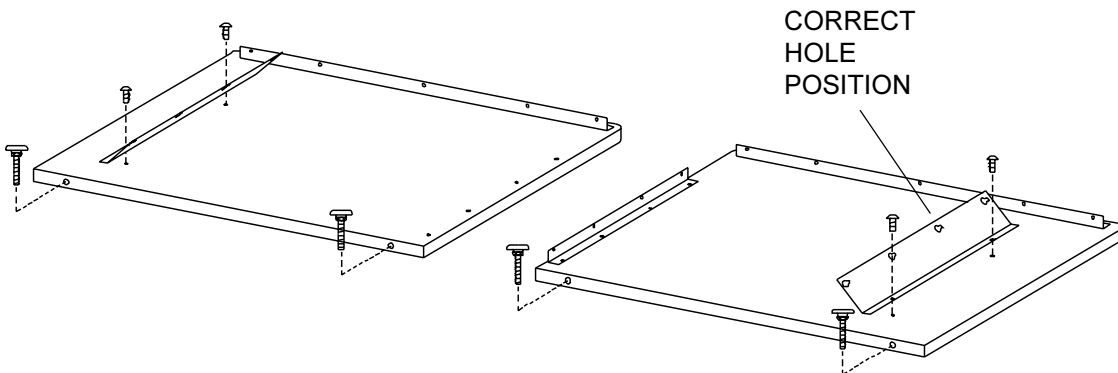
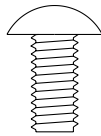

STEP 2

Attach the angled support brackets to each side panel as shown. **NOTE:** Make sure the pear shaped holes are positioned as shown. The larger hole faces the bottom and the smaller hole faces the top. Also twist glides into the bottom edges of the end panels.

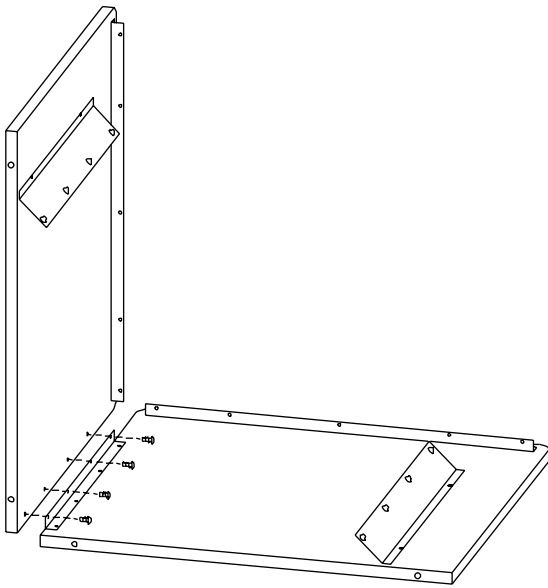

STEP 3

Attach the end panels together through the middle bracket using the 1/4-20 x 1/2" machine screws as shown.

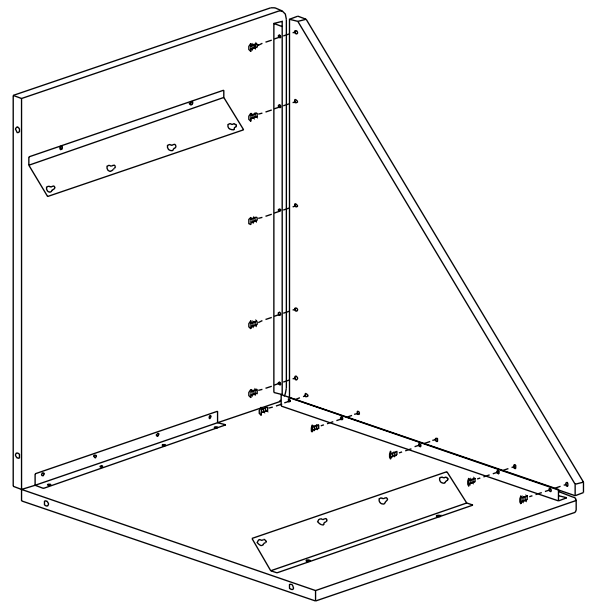

STEP 4

Attach the top panel to the end panels through the brackets as shown using the 1/4-20 x 1/2" machine screws.

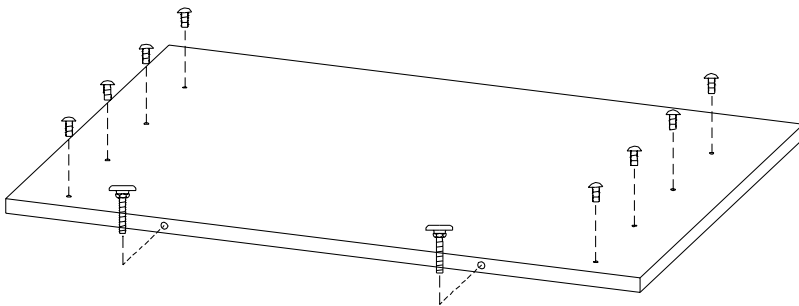

STEP 5

Lay the modesty panel down with holes facing up. **LOOSELY** install the 1/4-20 x 3/4" socket cap screws (about 3 turns). Twist glides into the bottom edge as shown.

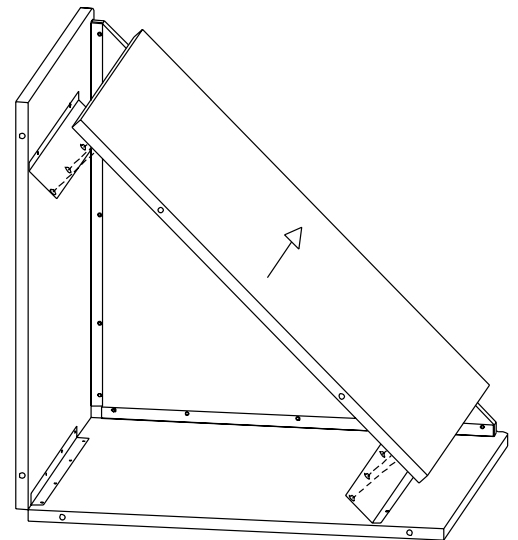
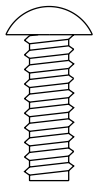

STEP 6

Place the modesty panel on the angled brackets so that the **screws** in the panel are **seated** in the **large holes** in the brackets. Then **slide** the modesty panel **upward** so that the **screws** are now **seated** into the **small holes**. **TIGHTEN** all screws. **CAREFULLY** stand unit upright.

IMPORTANT NOTE: Once unit is fully assembled, final position should be determined. The rest of your circulation desk assembly should be done off this unit. Once entire arrangement is assembled, it cannot be moved.

LEGACY CIRCULATION DESK

Rectangle Worksurfaces

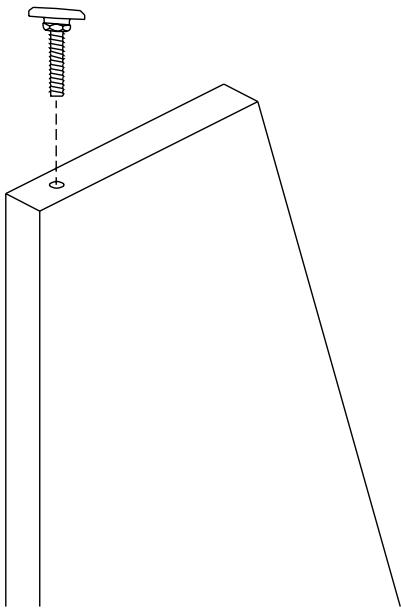
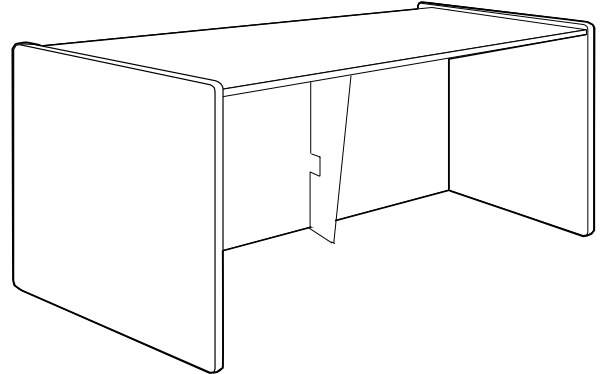
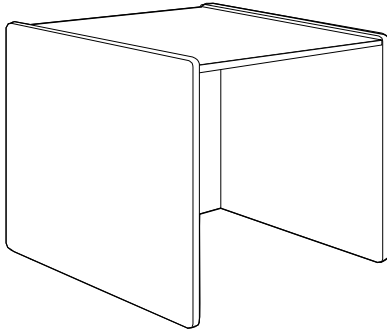

STEP 1

Twist on all glides to bottom of both end panels and to wood support leg (72" units only) as shown.

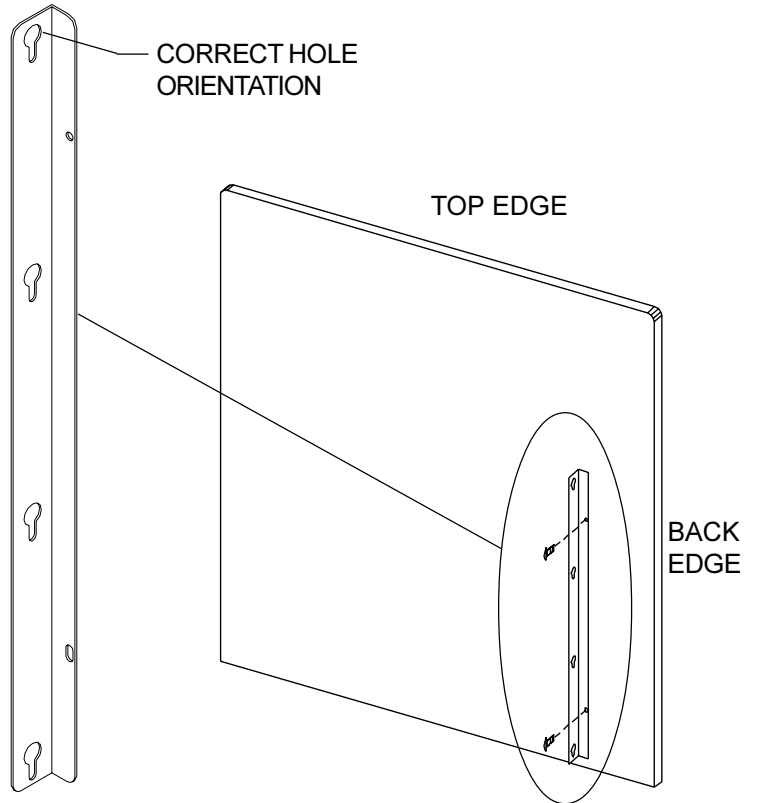

STEP 2

Position and attach L-brackets with pear shaped holes to each end panel using 1/4-20 x 1/2" machine screws as shown.

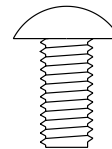

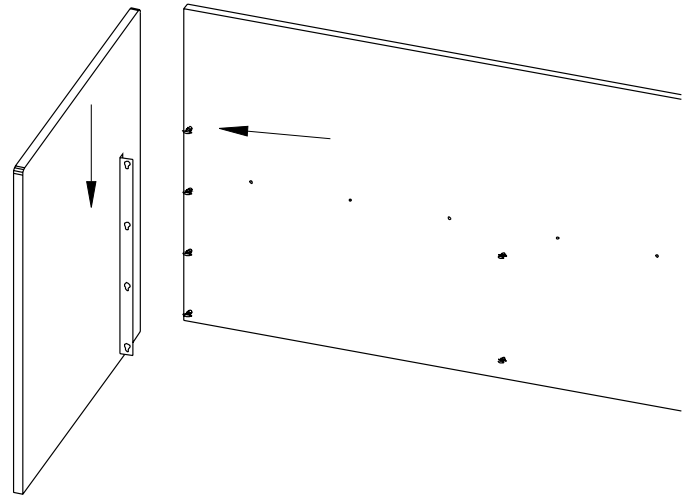
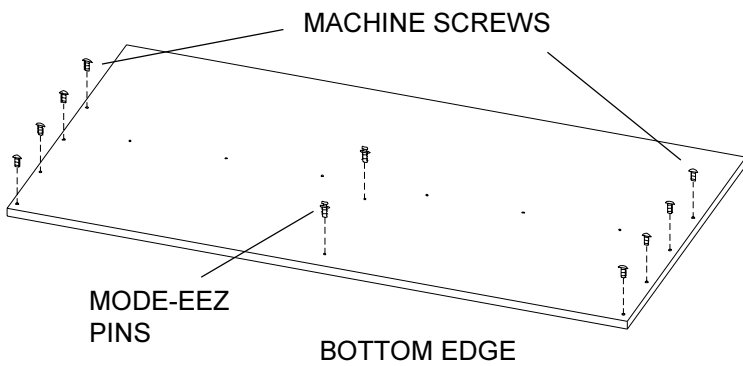

STEP 3

On the outside edges of the back panel, **LOOSELY** install 1/4-20 x 1/2" machine screws (about 3 turns). Also fully install Mod-EEZ pins for wood support leg (72" units).

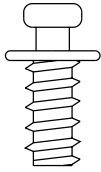

STEP 4

Align back panel with one end panel, then lower back panel into place until screws are securely seated into the pear shaped bracket holes. **TIGHTEN** all 4 screws. Attach the other end panel in the same manner.

NOTE: It may be helpful to have someone assist you during this step.

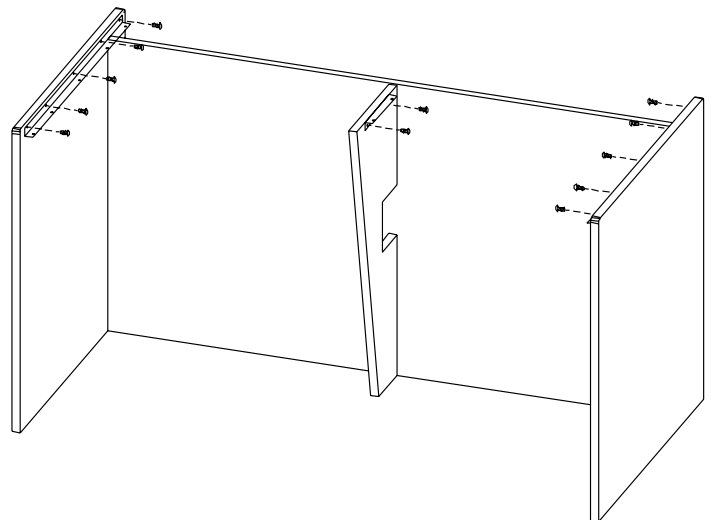
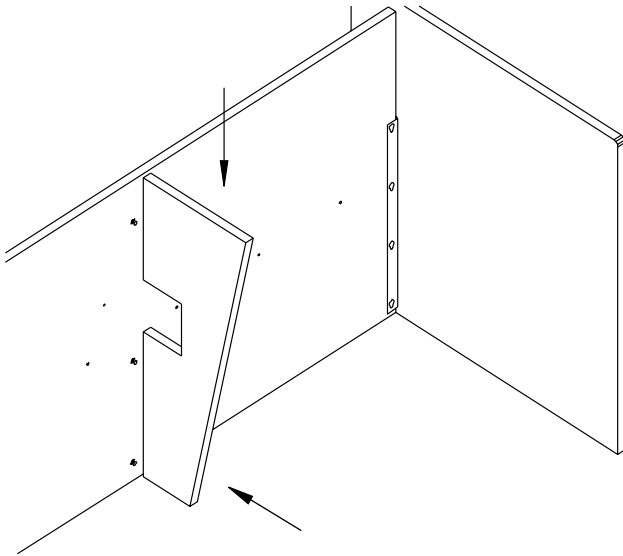

STEP 5 (FOR 72" MODELS ONLY)

Position wood support leg over screws in back panel. Tap leg into place until screws lock into inserts in support leg. A rubber mallet may be used to tap leg in place.

NOTE: Wood support leg size will vary based on unit height.

STEP 6

Position L-brackets on end panels and wood supports leg as shown. Secure with 1/4-20 x 1/2" machine screws.

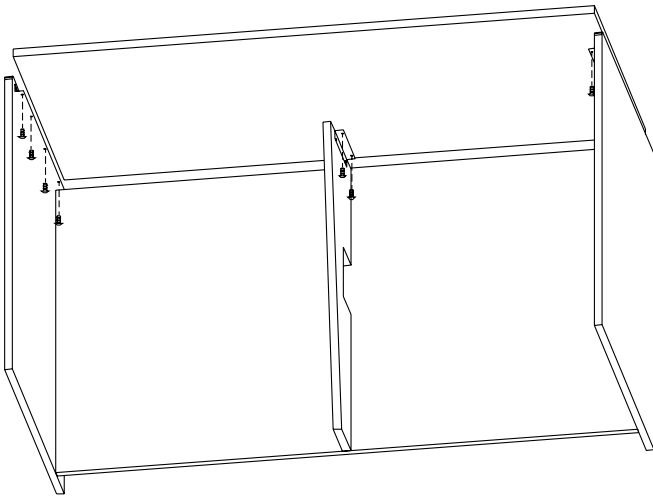

VIEW FROM UNDERNEATH

STEP 7

Mount work surface between end panels as shown. Secure through L-brackets with 1/4-20 x 1/2" machine screws as shown.

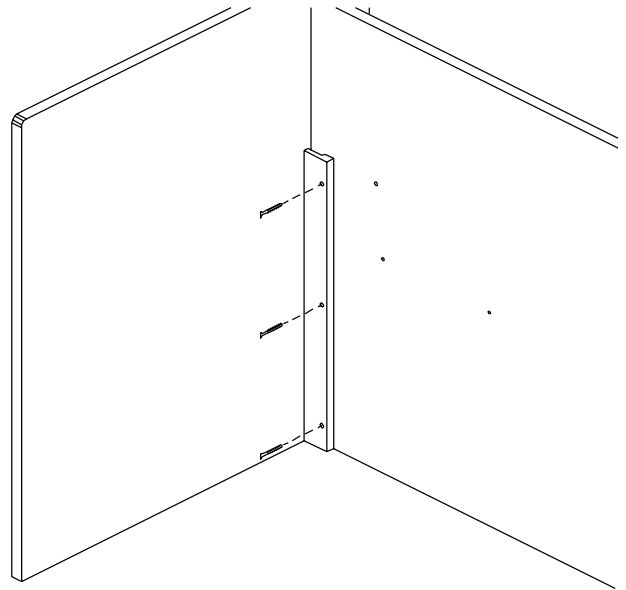

STEP 8

Attach wood corner brackets in each corner to hide L-brackets as shown. Secure with 1 1/4" screws.

NOTE: Make sure the bottom edge of the corner bracket is flush with the bottom edge of the back panel.

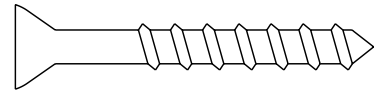

BOOK DROP INSTALLATION

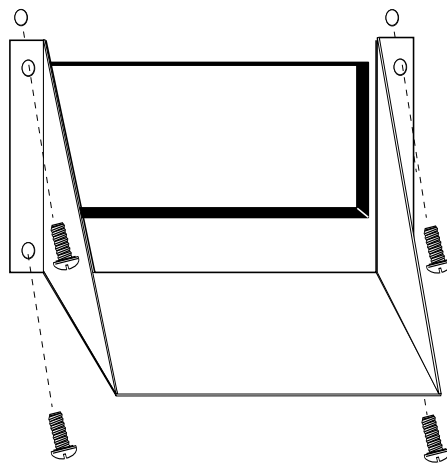

Fasten book drop to back panel with 1/4 x 20 x 1/2" machine screws as shown.

LEGACY CIRCULATION DESK

Trapezoid Worksurfaces

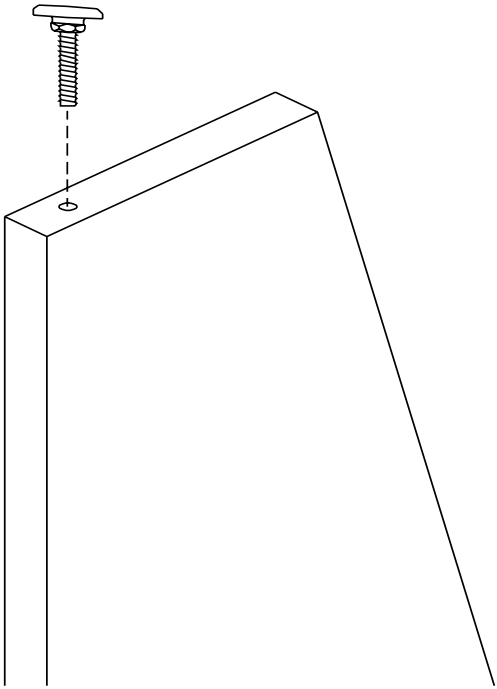
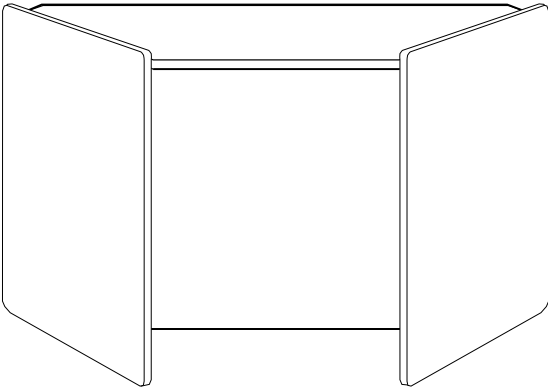

STEP 1

Twist on all glides to bottom of both end panels as shown.

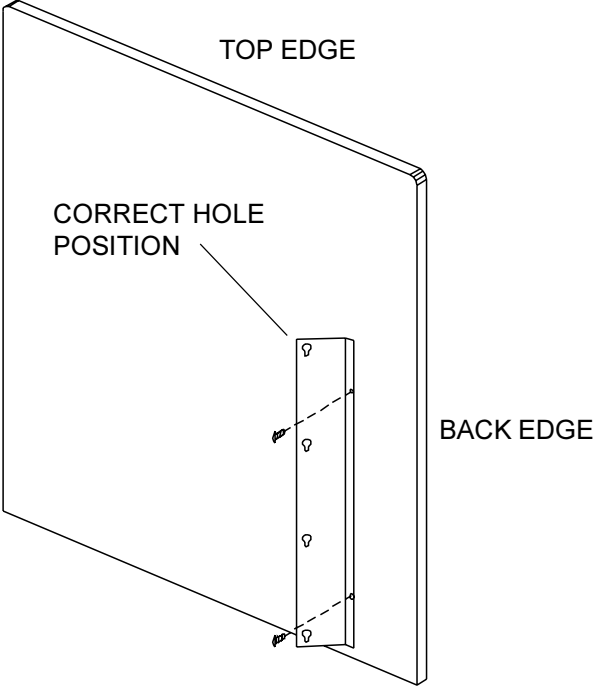

STEP 2

Position and attach L-brackets with pear shaped holes to each end panel using 1/4-20 x 1/2" machine screws as shown.

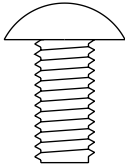

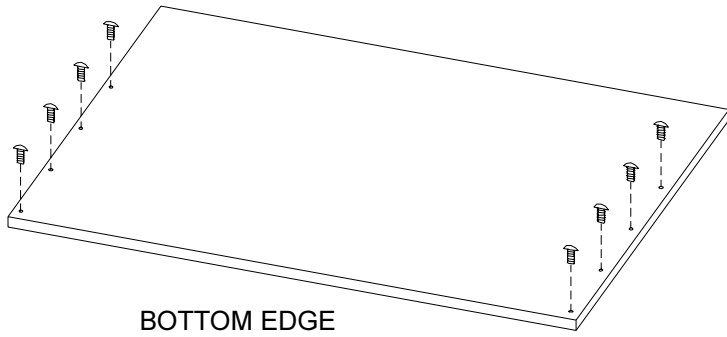

BOTTOM EDGE

STEP 3

On the outside edges of the back panel, **LOOSELY** install the 1/4-20 x 3/4" socket cap screws (about 3 turns).

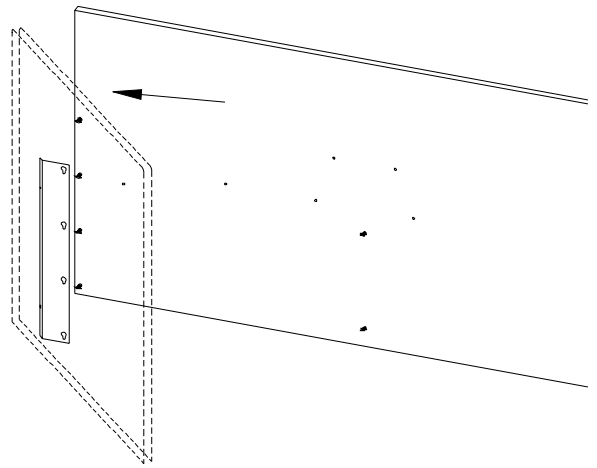
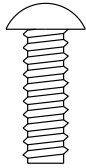

STEP 4

Align back panel with one end panel, then lower back panel into place until screws are securely seated into the pear shaped bracket holes. **TIGHTEN** all 4 screws with Allen wrench provided. Attach the other end panel in the same manner.

NOTE: It may be helpful to have someone assist you during this step.

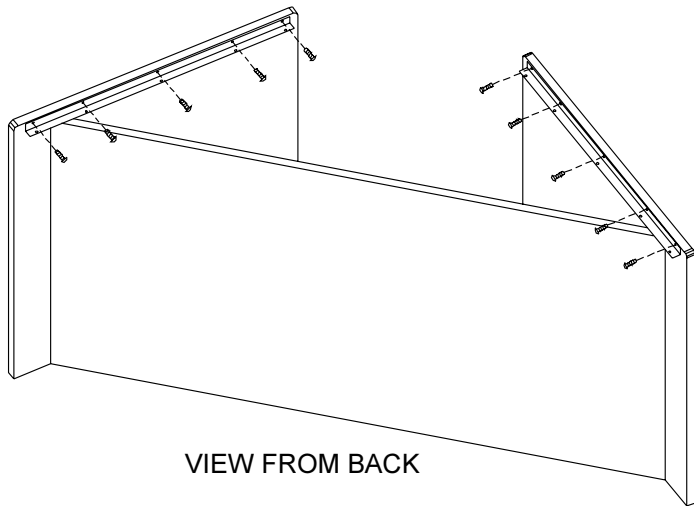

VIEW FROM BACK

STEP 5

Position L-brackets on the end panels as shown. Secure with 1/4-20 x 1/2" machine screws.

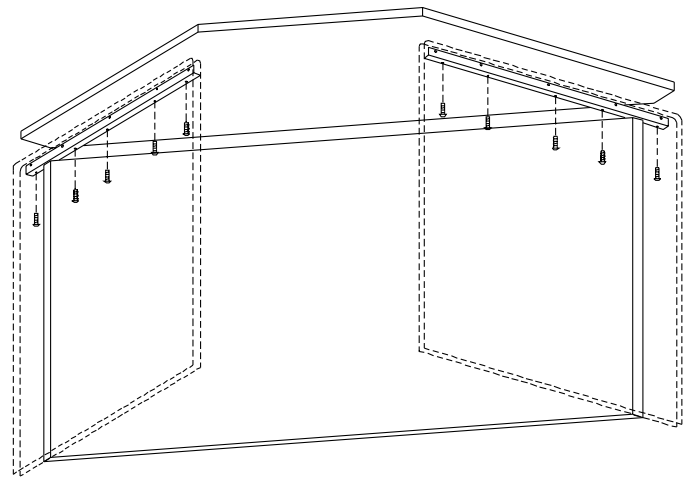

VIEW FROM FRONT & UNDERNEATH

STEP 6

Mount work surface between end panels as shown. Secure through L-brackets with 1/4-20 x 1/2" machine screws as shown.

LEGACY CIRCULATION DESK

Transaction Counters

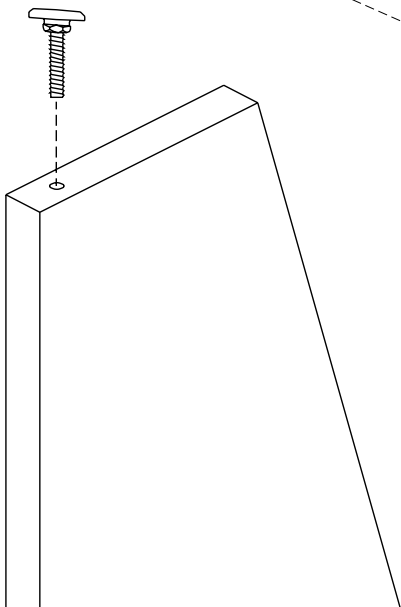
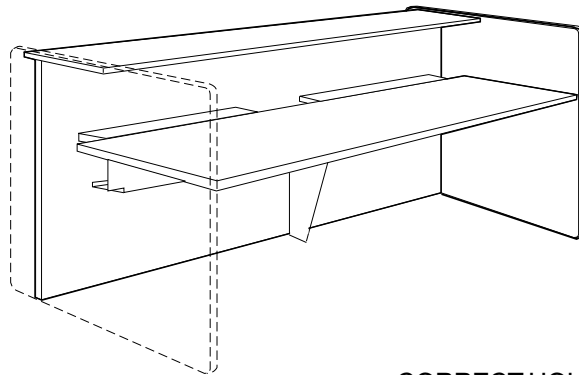
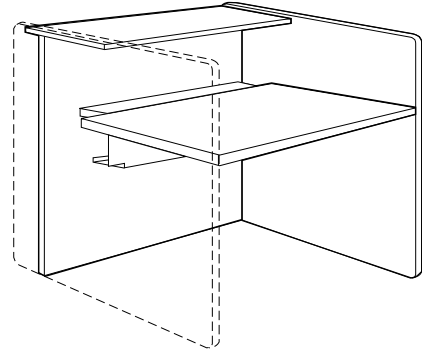
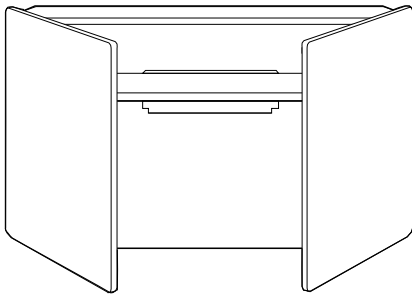

STEP 1

Twist on all glides to bottom of both end panels and to wood support leg (72" units only) as shown.

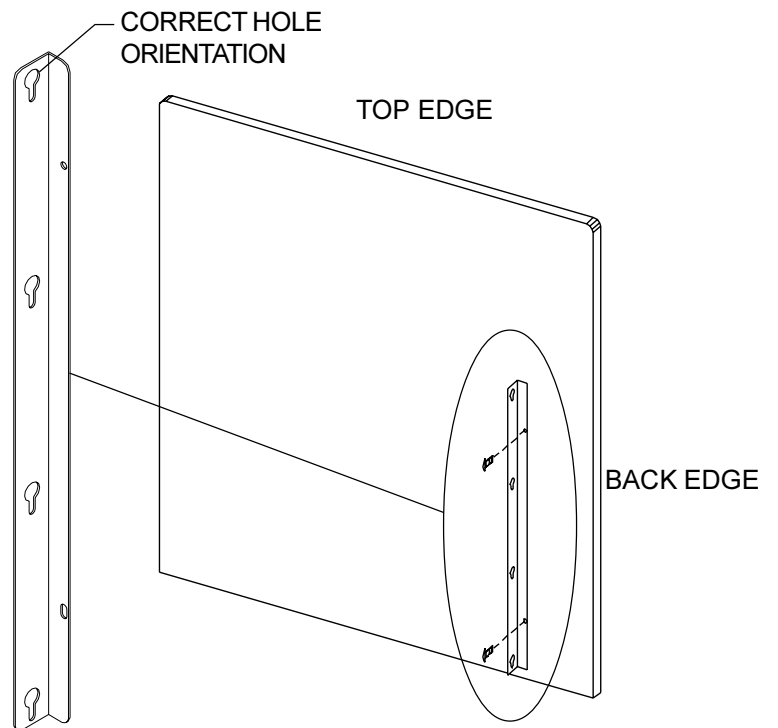

STEP 2

Position and attach L-brackets with pear shaped holes to each side panel using 1/4-20 x 1/2" machine screws as shown.

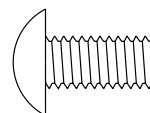

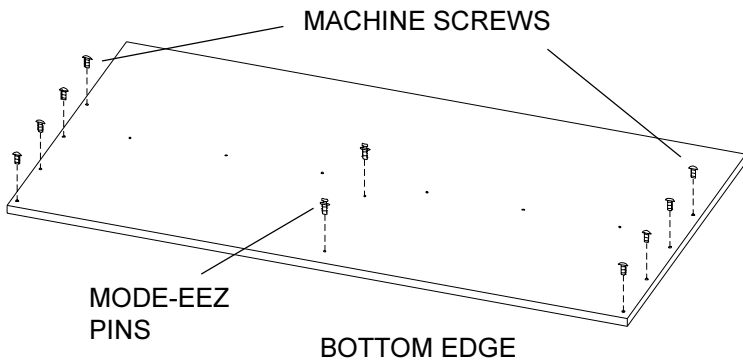

STEP 3

On the outside edges of the back panel, **LOOSELY** install 1/4-20 x 1/2" machine screws (about 3 turns). Also fully install Mod-EEZ pins for wood support leg (72" units).

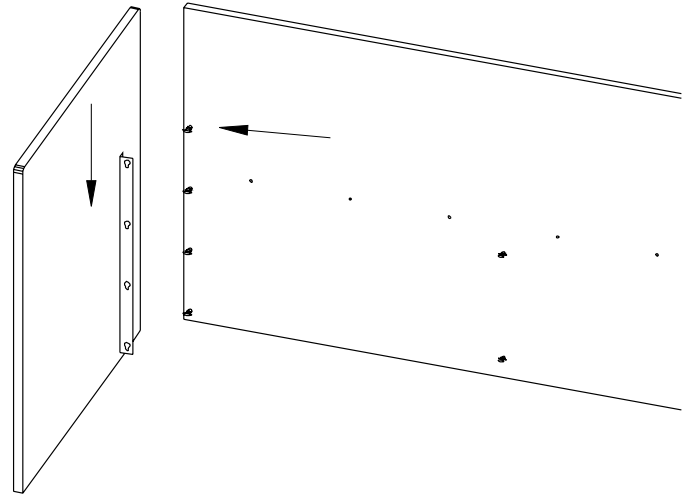
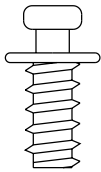

STEP 4

Align back panel with one end panel, then lower back panel into place until screws are securely seated into the pear shaped bracket holes. **TIGHTEN** all 4 screws. Attach the other end panel in the same manner.

NOTE: It may be helpful to have someone assist you during this step.

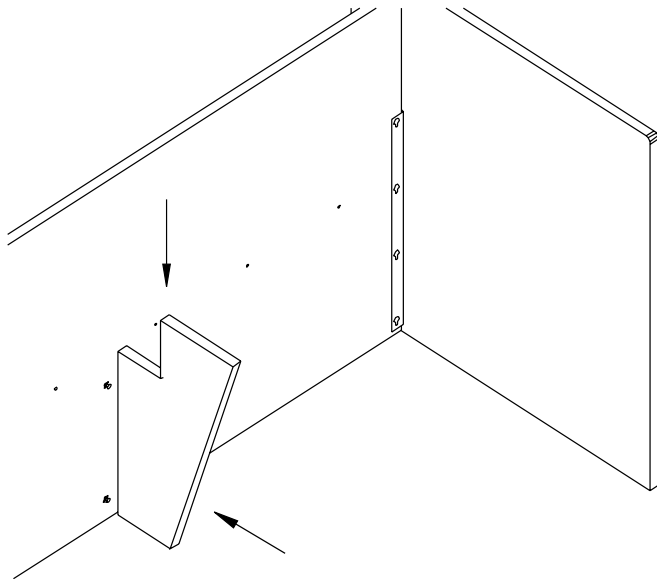

STEP 5

FOR 72" RECTANGLE MODELS ONLY:

Position wood support leg over screws in back panel. Tap leg into place until screws lock into inserts in support leg. A rubber mallet may be used to tap leg in place.

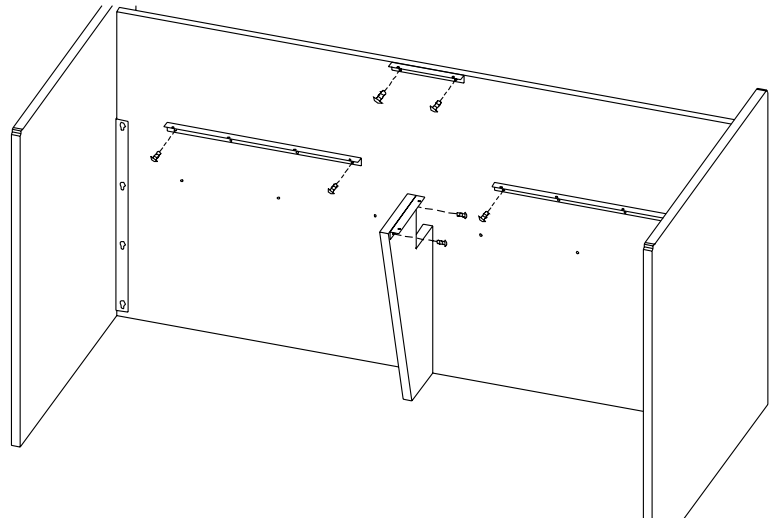

STEP 6

Position L-brackets on back panel and support leg as shown. Secure with 1/4-20 x 1/4" machine screws.

NOTE: Different size units will have a different number of L-brackets. A LTC7239 unit is shown in this picture.

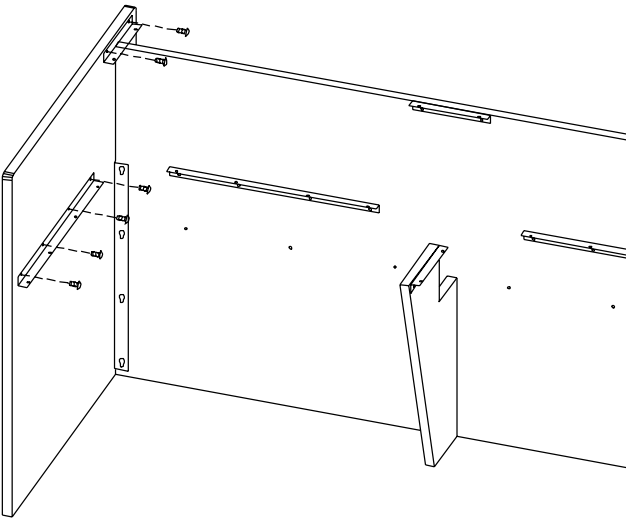

STEP 7

Position L-brackets to each end panel as shown. Secure with 1/4-20 x 1/2" machine screws.

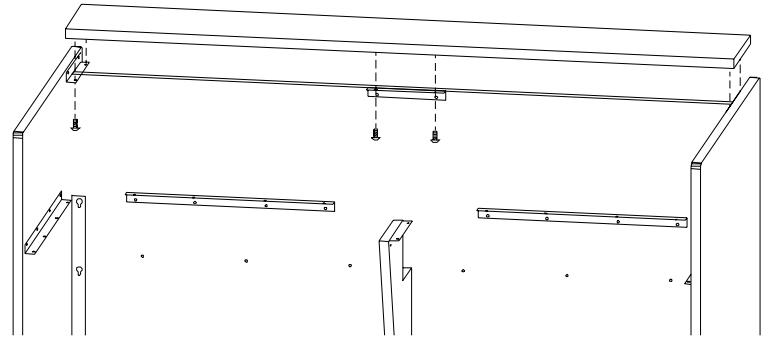

STEP 8

Mount reference shelf between end panels as shown. Secure through L-brackets with 1/4-20 x 1/2" machine screws as shown.

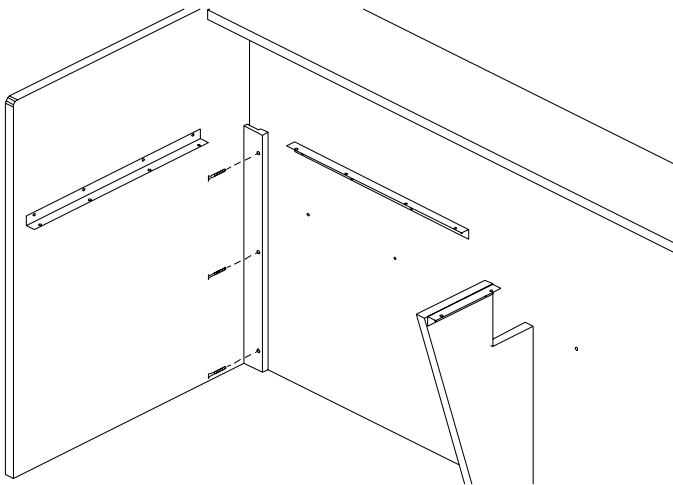

STEP 9

Attach wood corner brackets in each corner to hide L-brackets as shown. Secure with 1 1/4" screw.

NOTE: Make sure the bottom edge of the corner bracket is flush with the bottom edge of the back panel. If it is not flush, it may cause the cord bin covers to fit incorrectly.

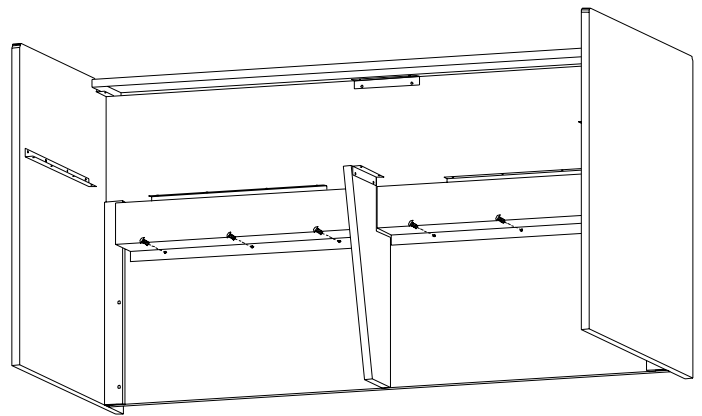
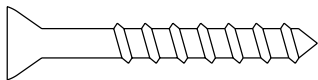

VIEW FROM UNDERNEATH

STEP 10

Attach cord bins to back panel as shown using pan head wood screws.

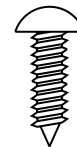

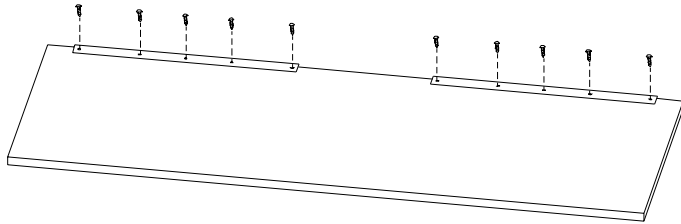

FRONT EDGE

STEP 11

Attach support bar to back edge of the work surface using pan head wood screws as shown.

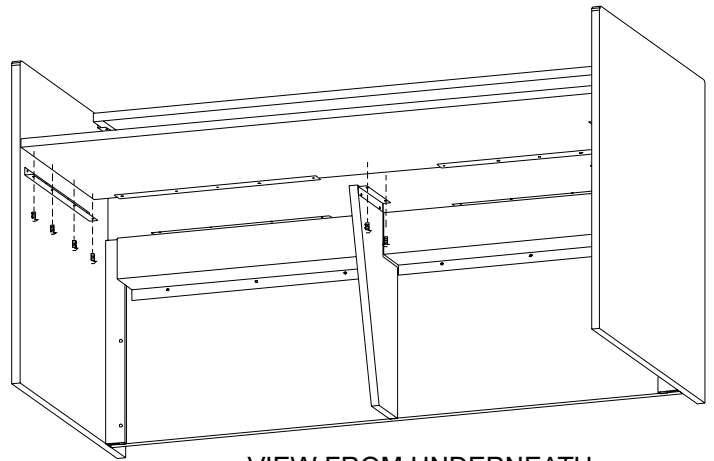

VIEW FROM UNDERNEATH

STEP 12

Mount work surface between end panels with support bar facing the inside of the unit. Secure through L-brackets using 1/4-20 x 1/2" screws as shown.

NOTE: If work surface does not fit correctly, check to see if support leg is secure and if glides are positioned equally.

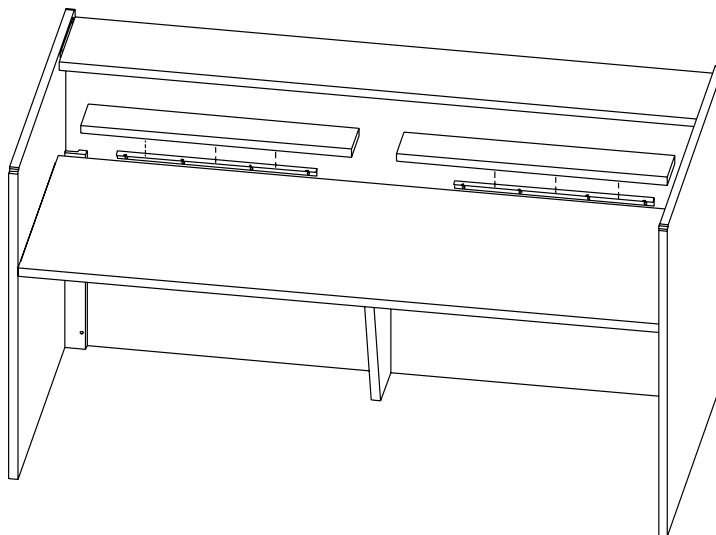

STEP 13

Lay cord bin covers between work surface and back panel as shown.

Bretford
11000 Seymour Avenue
Franklin Park, IL 60131
TEL: 847.678.2545
800.521.9614
FAX: 847.678.0852
800.343.1779

Bretford Ltd.
Technology House
7 Lake End Court, Taplow
Bucks SL6 0JQ England
TEL: 01628 603558
FAX: 01628 604923

www.bretford.com

Part# 031-2717
Rev. 06.02.04 CH