

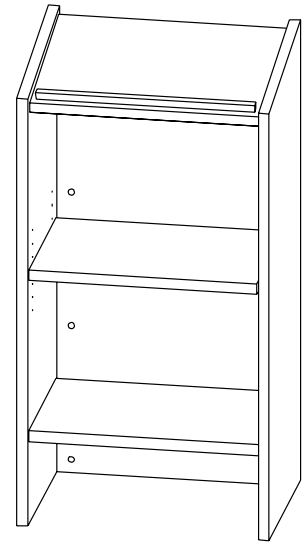

# LEGACY COLLECTION

## LDSTD DICTIONARY STAND

### Assembly Instructions



#### PARTS LIST

Qty	Description
1	Right Side Panel
1	Left Side Panel
1	Back Panel
1	Fixed Bottom Shelf
1	Fixed Top Shelf
1	Top Shelf Stop
1	Adjustable Middle Shelf

#### HARDWARE LIST

Ref	Qty	Description
AA	4	Glides
BB	16	Wood Dowels
CC	16	Locking Pins
DD	16	Locking Cams
EE	4	#8 x 1 1/2" Flat Head Screws
FF	4	Collar Pins

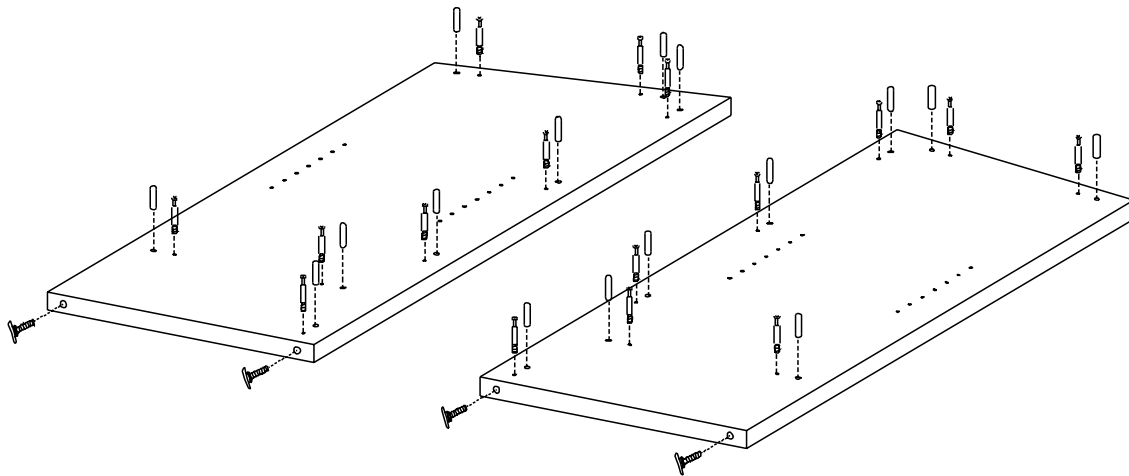

#### STEP 1

Lay both side panels on a carpeted surface with the holes facing up. Insert the dowels (BB) and pins (CC) on the surface of the panels as shown. Use a screwdriver to fasten pins. The dowels go into the large holes and the pins go into the small holes. Insert the glides (AA) into the edge of the panels as shown. **NOTE:** If necessary, a rubber mallet or hammer may be used to tap the dowels into place. **ONLY** tap once or twice so the surface or dowels do not crack.

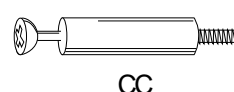
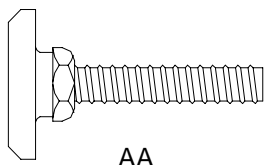

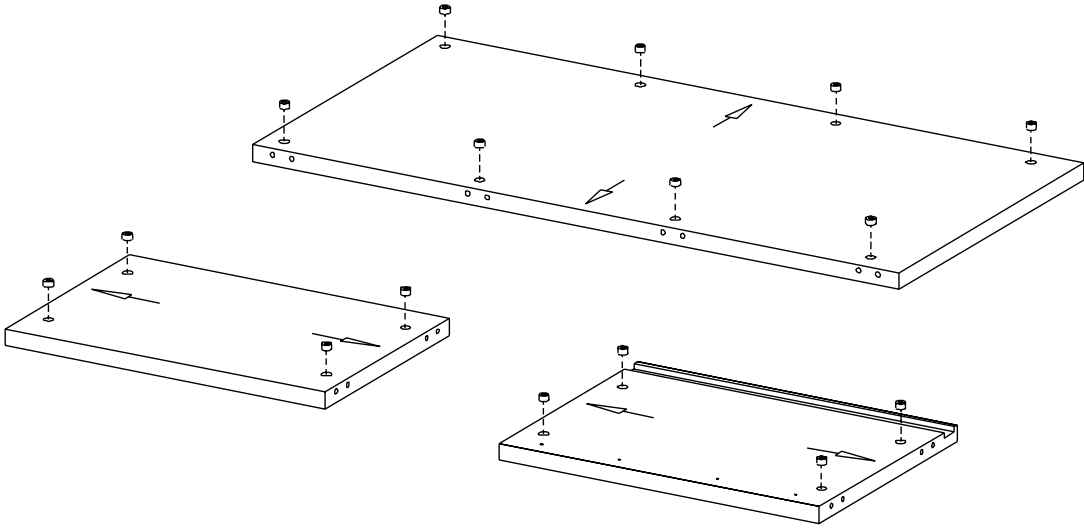

## STEP 2

Lay the back panel and the top and bottom shelves on a carpeted surface with holes facing up. Insert the cams (DD) into each panel as shown. **NOTE:** The arrows on each part represent the direction the arrow on the cam should face.

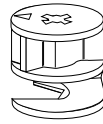

DD

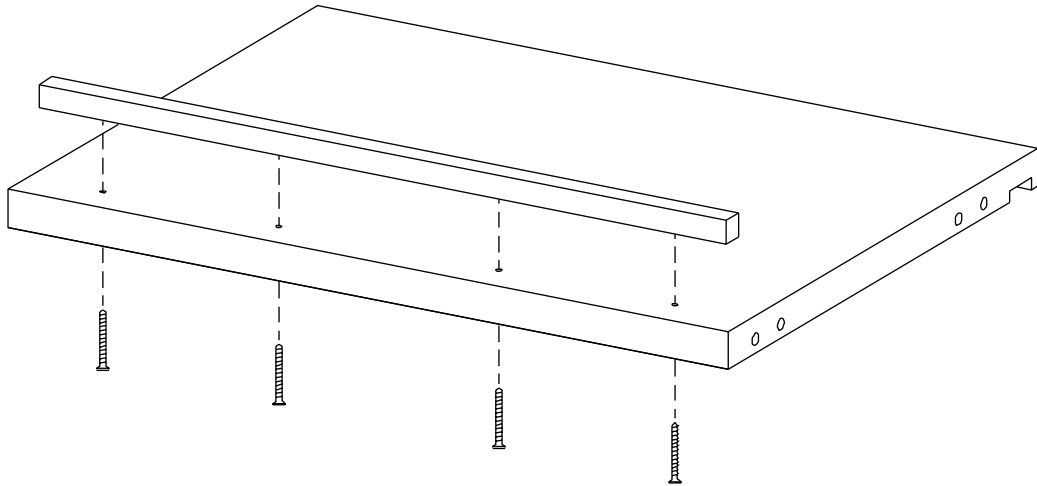

## STEP 3

Attach the shelf stop to the top shelf's surface using screws (EE) as shown.

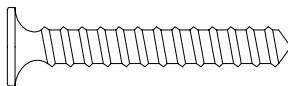

EE

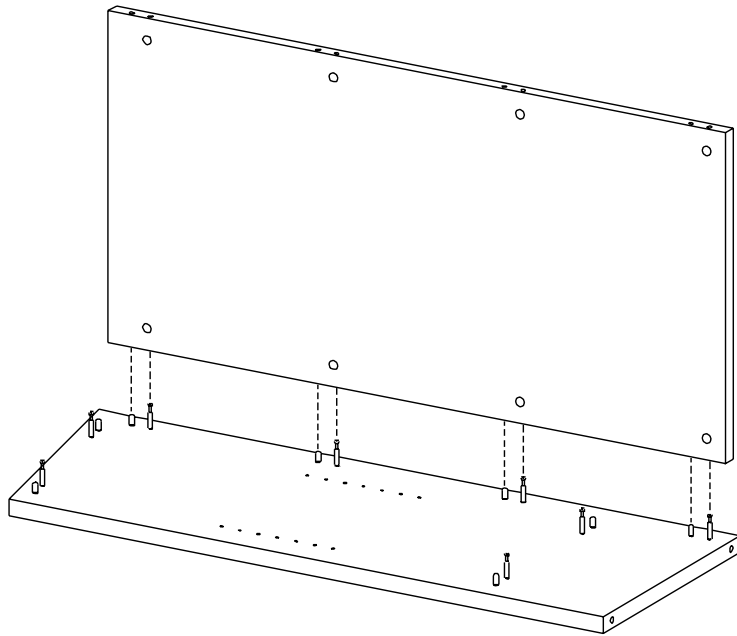

#### STEP 4

Join the back panel to one of the side panels with the cams facing in as shown.

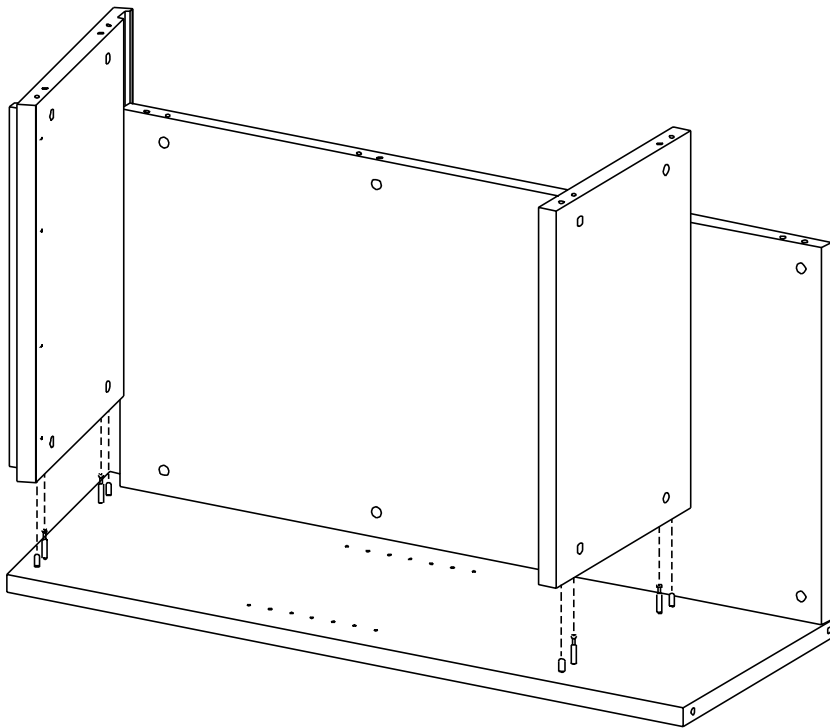

#### STEP 5

Join the top and bottom panels to the side panel as shown.

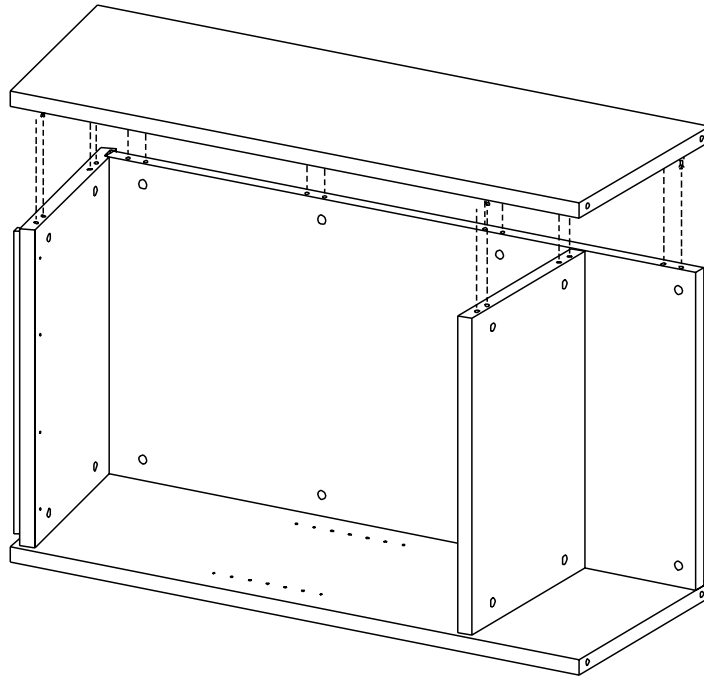

### STEP 6

**CAREFULLY** position the other side panel onto the back panel and the top and bottom panels as shown. **TIGHTEN ALL CAMS.**

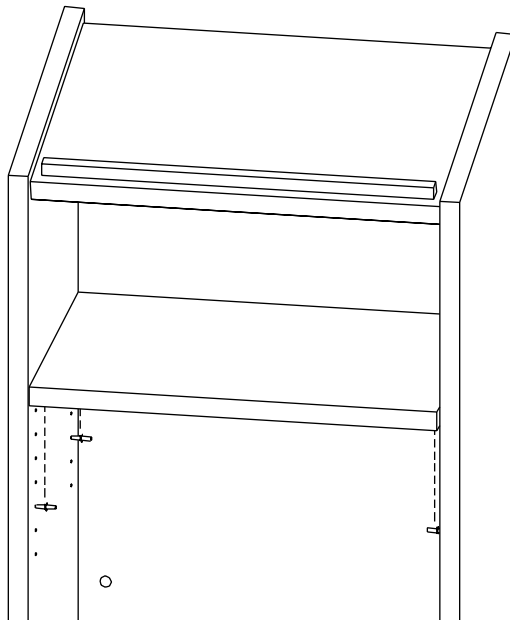

### STEP 7

Stand unit upright. Insert collar pins (FF) in a set of holes at the desired location you wish to have your shelf. Place the shelf onto the collar pins.

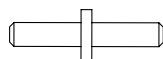

FF

**Bretford**  
 11000 Seymour Avenue  
 Franklin Park, IL 60131  
 TEL: 847.678.2545  
 800.521.9614  
 FAX: 847.678.0852  
 800.343.1779

**Bretford Ltd.**  
 Technology House  
 7 Lake End Court, Taplow  
 Bucks SL6 0JQ England  
 TEL: 01628 603558  
 FAX: 01628 604923

[www.bretford.com](http://www.bretford.com)

Part #031-2376  
 10.95 CH