

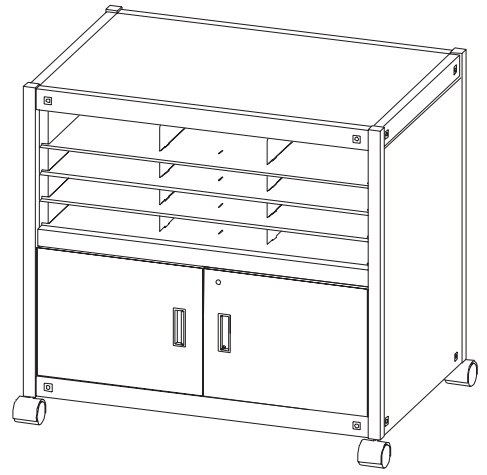

BRETFORD

FAX2 OFFICE MACHINE STAND Assembly Instructions



PARTS LIST

Qty	Part#	Description	Ref
1	010-1224	Bottom Shelf	AA
1	010-1993	Top Shelf	BB
1	010-1995	Rear Panel	CC
3	010-1999	Divider Shelves	DD
8	010-2000	Shelf Dividers	EE
1	022-0752	Left Door Assembly	FF
1	022-0753	Right Door Assembly w/ Lock	GG
2	022-1489	Rear Leg Assemblies	
1	022-1490	Right Front Leg Assembly	
1	022-1491	Left Front Leg Assembly	
1	022-1494	Right Side Panel	
1	022-1495	Left Side Panel	
1	022-1502	Center Shelf Assembly	
4	015-0054	2" Casters w/ Brake	

HARDWARE LIST

Qty	Part#	Description
16	030-0300	5/8" Square Head Bolts
16	030-0002	5/16-18 Serrated Nuts
2	030-0023	#6-32 x 3/8" Machine Screws
2	030-0024	#6-32 Hex Nuts
2	030-0367	5/32" Dia. x 3/4" Long Cotter Pins
4	030-0259	#10 x 1/2" Phillips Pan Head Screws
4	030-0325	1/4-20 x 1/2" Combo Truss Screws
1	010-1188	Door Stop
2	012-0286	Plastic Door Handles
1	010-2003	Hex Wrench

TOOLS REQUIRED

- Hex Wrench (Provided)
- Phillips Screwdriver
- Adjustable Wrench
- Rubber Mallet

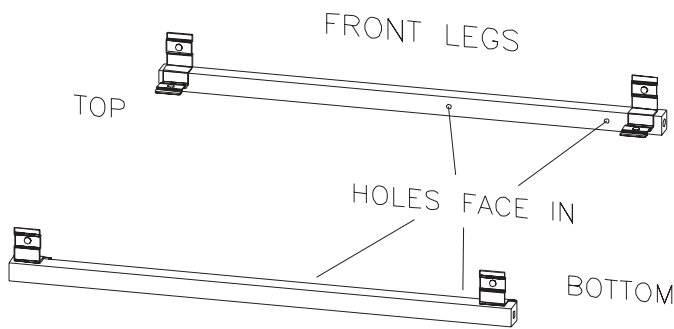

FIGURE 1

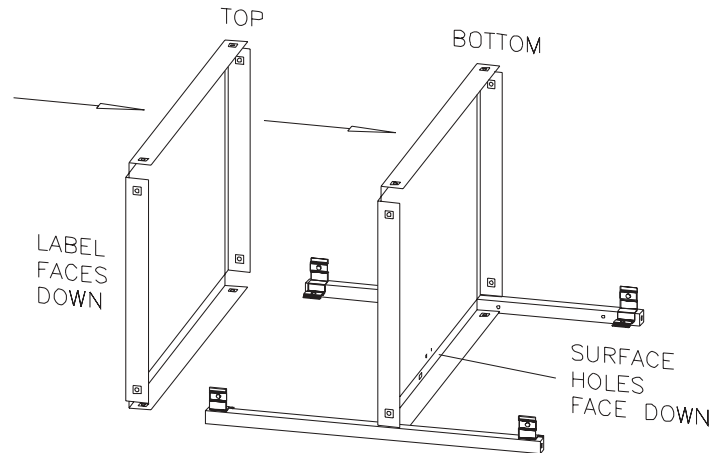
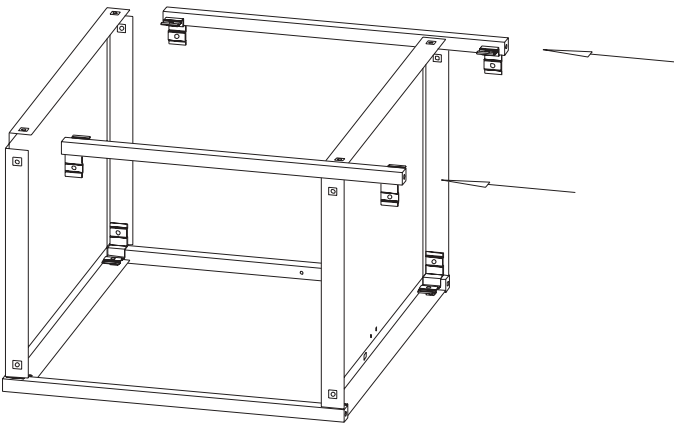

FIGURE 2

STEP 1

Position the 2 front legs (the ones with the holes) on a carpeted surface with holes facing in and the brackets facing in and up as shown in **FIGURE 1**. Slide the top and bottom shelves onto legs so that the brackets are inside the shelves as shown in **FIGURE 2**.

NOTE: Make sure the shelves are positioned as noted.



STEP 2

Slide the 2 rear legs onto the shelves so that the brackets are position inside and underneath the shelves.

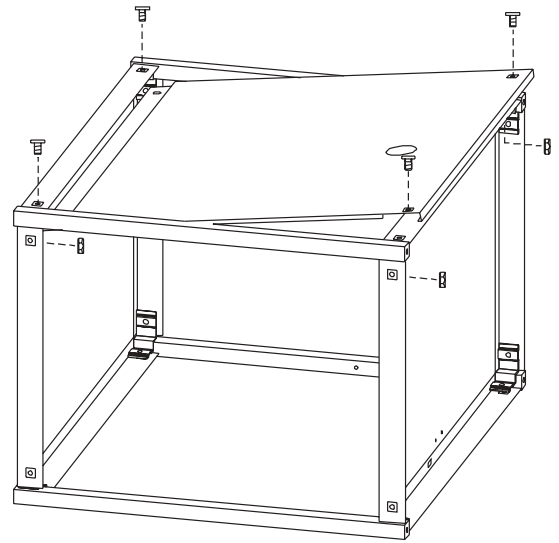

STEP 3

Position rear panel so that the top edge slides in front of the brackets and the bottom flange hooks onto the bottom shelf. **LOOSELY** attach with bolts (AA) and nuts (BB) as shown.

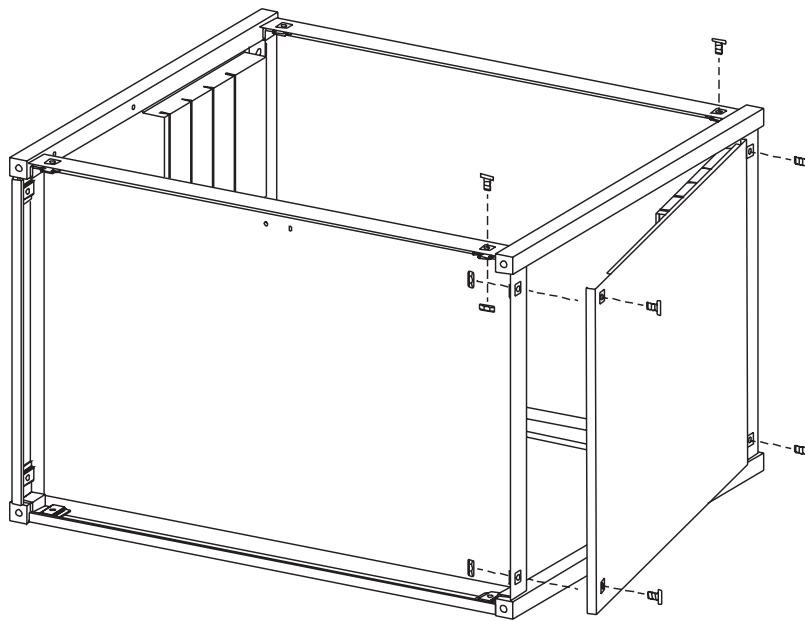
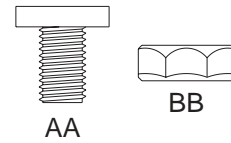

STEP 4

CAREFULLY rotate the unit onto its back. Attach each side panel in the same manner as the rear panel. **LOOSELY** attach with bolts (AA) and nuts (BB) as shown.

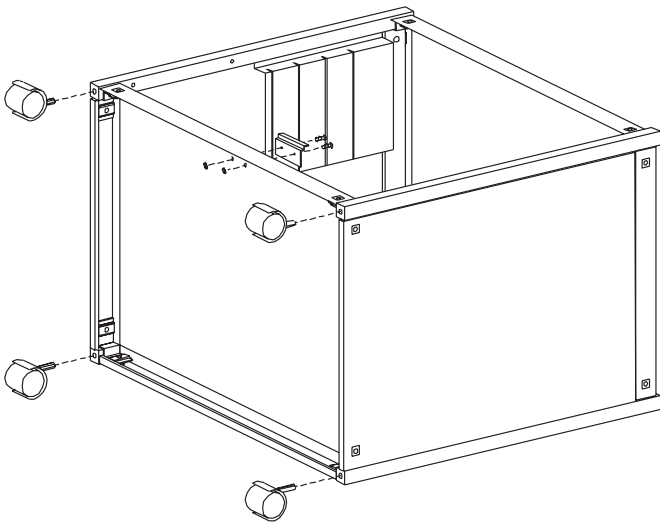

STEP 5

LOOSELY attach the door stop to the bottom shelf using screws (CC) and nuts (DD) as shown. **NOTE:** Final adjustment of the door stop will be done when doors are attached. Push casters into each leg. If casters do not insert easily, use a rubber mallet to tap casters in place. **TIGHTEN ALL BOLTS AND NUTS.** Make sure casters are **SECURELY** in place before standing unit up.

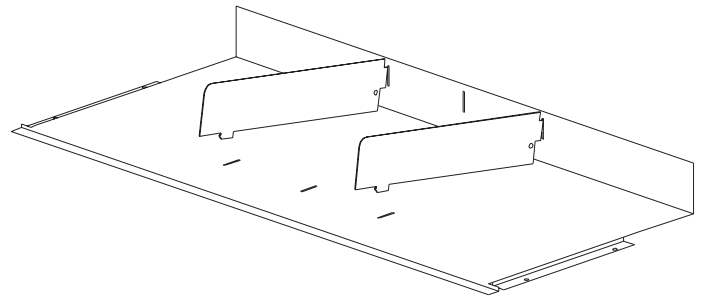
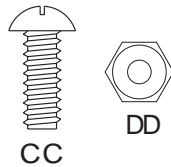

STEP 6

Insert dividers into all 4 shelves as shown. The tab on the back edge of the divider hooks into the slot on the rear flange of the shelf and the front tab inserts into the slot on the surface of the shelf.

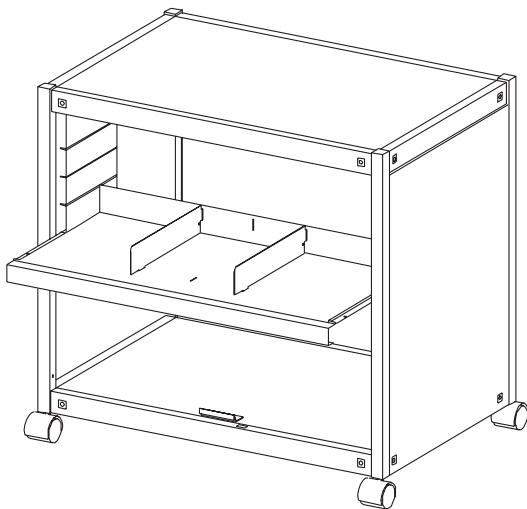

FIGURE 3

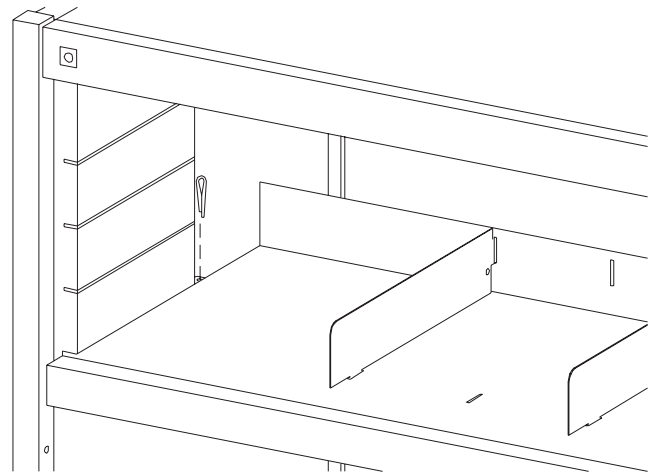
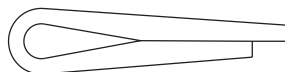

FIGURE 4

STEP 7

Slide the center shelf (it has a 2" front flange) into the lowest slot of the side panels as shown in **FIGURE 3**. In each corner of the shelf, drop the cotter pin (EE) into the shelf's hole as shown in **FIGURE 4**. This will keep the shelf in place.



EE

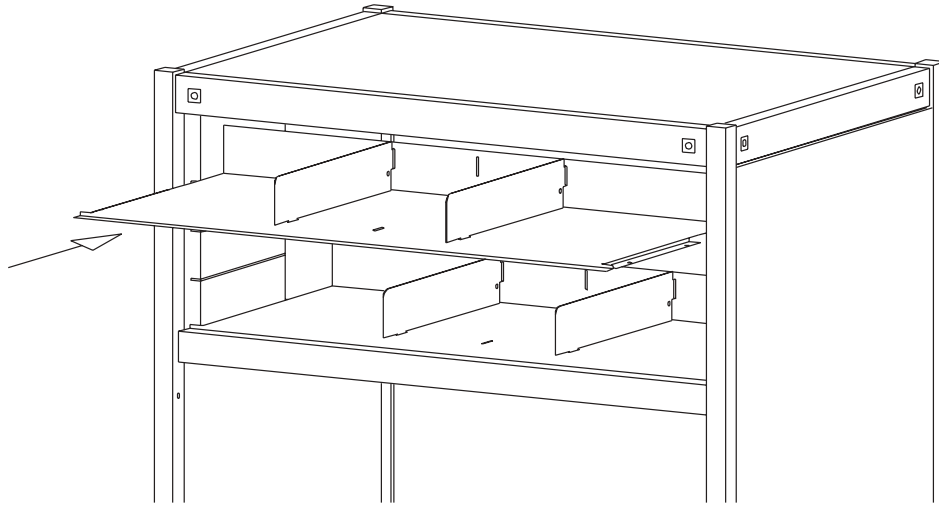

STEP 8

Starting front the top, slide the 3 remaining shelves into the slots in the side panels. **NOTE:** Some force may need to be used to slide shelves in place.

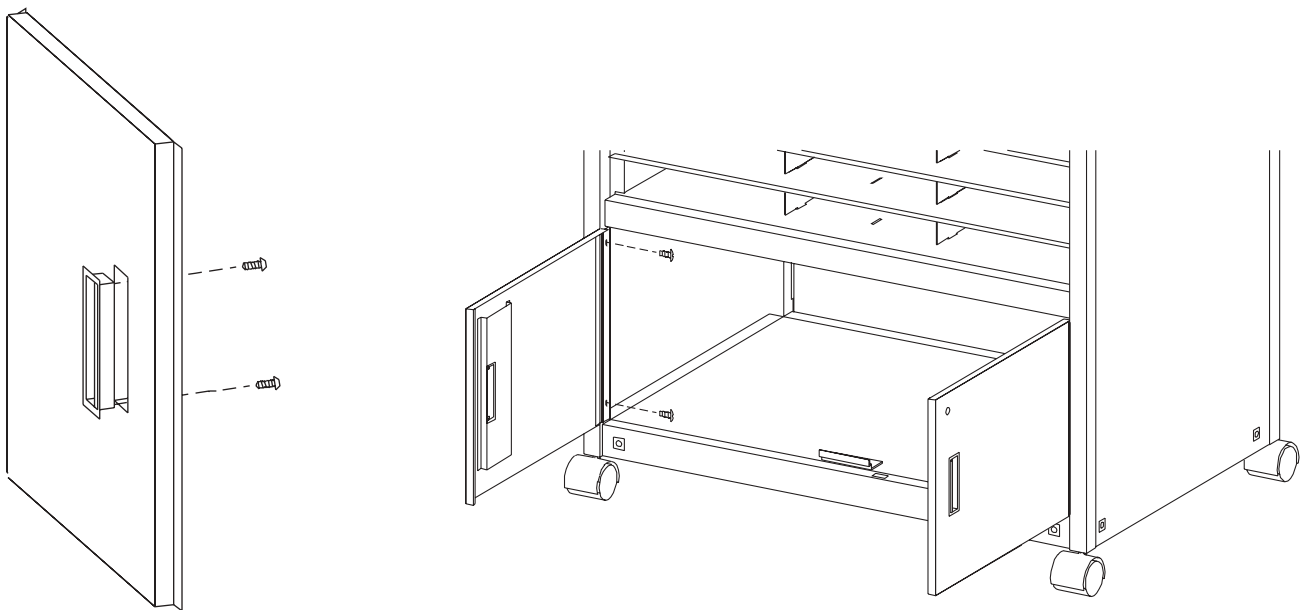

STEP 9

Attach each handle onto the doors using screws (FF) as shown.

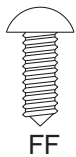

STEP 10

Attach each door (right door has lock) to the legs using screws (GG) as shown. Once both doors are attached adjust and tighten the door stop.

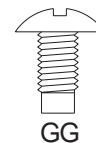

Bretford
 11000 Seymour Avenue
 Franklin Park, IL 60131
 TEL: 847.678.2545
 800.521.9614
 FAX: 847.678.0852
 800.343.1779

Bretford Ltd.
 Technology House
 7 Lake End Court, Taplow
 Bucks SL6 0JQ England
 TEL: 01628 603558
 FAX: 01628 604923