



BRETFORD™

BRETFORD LIBRARY SYSTEMS

IHC3656CS IHC3656CA

IHC4856CS IHC4856CA

ITHACA

DOUBLE FACE CARREL
STARTER AND ADD ON

Assembly Instructions

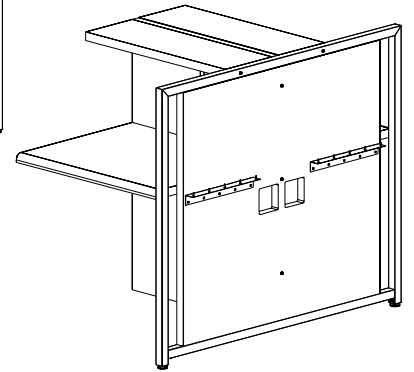
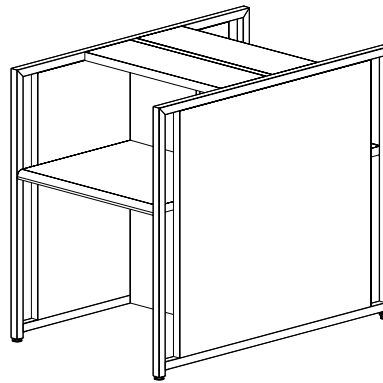

Parts List

Qty.	Description
1	Left Side Panel - Starter Model ONLY
1	Right Side Panel - Starter Model ONLY
1	Middle Panel - Add On Model ONLY
1	Back Panel - All Models
2	Worksurface - All Models
2	Shelf - All Models
2	Cord Management Bracket
6/8*	Worksurface Brackets
	*3656 Models use 6
	*4856 Models use 8

Hardware List

Ref.	Qty.	Part No.	Description
AA	4*	030-1146	7/32 x 11mm Modezz Screws
BB	6/8*	030-1147	11.5mm x 16mm Wood Screws
			*3656 Models use 6
			*4856 Models use 8
CC	4/2*	HD1128	1 3/4" X 3/8-16 Floor Glides
			*Starter Models use 4
			*Add On Models use 2
DD	58/80*	030-1148	#8 x 3/4" Phillips Pan Hd Wood Screws
			*3656 Models use 58
			*4856 Models use 80
EE	8	HD1015	MiniFix Cams
FF	8	HD1019	MiniFix Screw Bolts

SAFETY WARNING

**Note: TWO PERSON
ASSEMBLY REQUIRED**

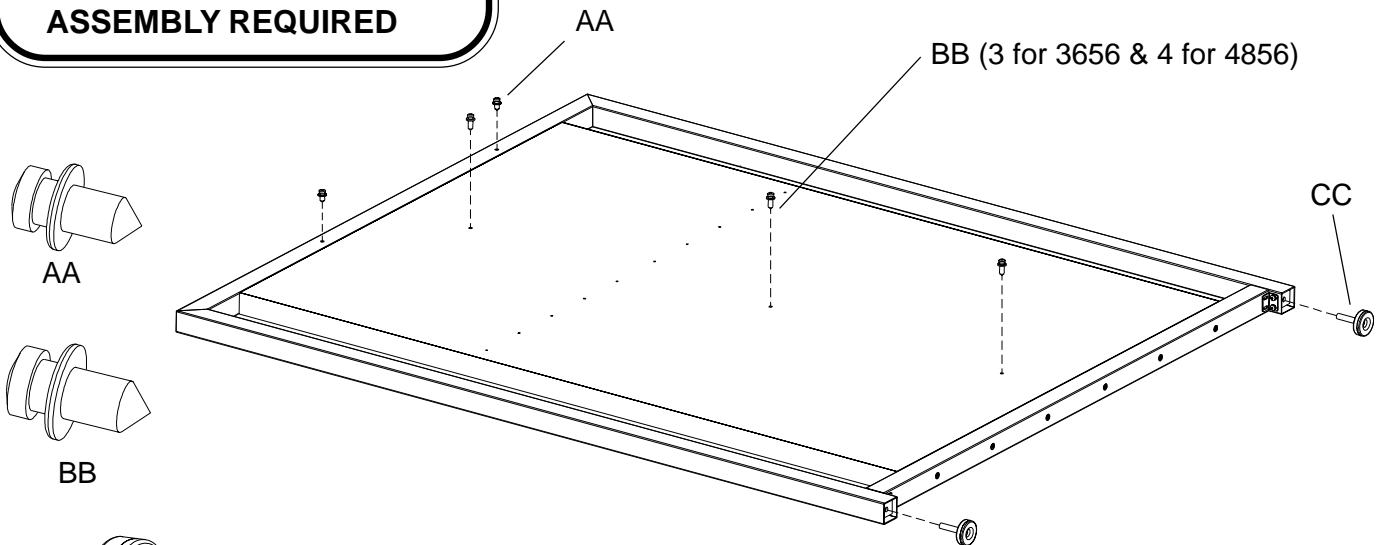

STEP 1

Lay each side panel down with holes facing up as shown. Install modezz screws (AA) into top edge holes, modezz screws (BB) into side edge holes and glides (CC) into leg bottoms. **NOTE: For middle panels, modezz screws are installed on both sides.**

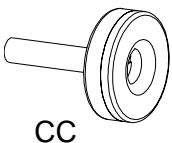
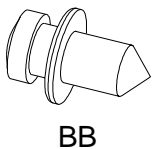
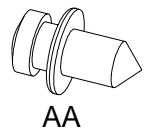

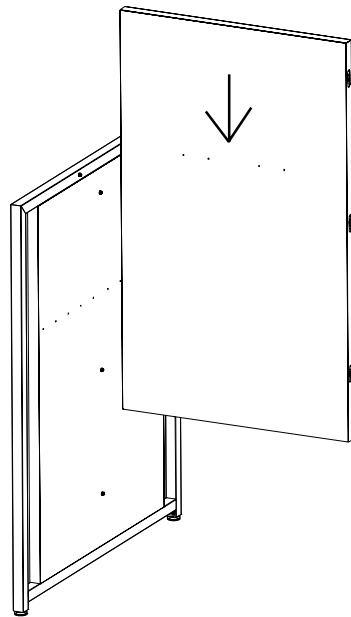

The next panel to install will be an end or middle panel depending on your final layout.

NOTE: If panel does not go down entirely, try backing out the modezz clip screws a 1/4 turn at a time.

STEP 2

With someone's help, attach the back panel to the side by lining up the modezz screw and modezz clip and then sliding into place. Attach the other side panel and/or middle panel in the same manner. **NOTE:** If you are assembling more than one unit, keep installing middle panels. The final end panel will get attached at the end of your row.

REPEAT ON OTHER SIDE

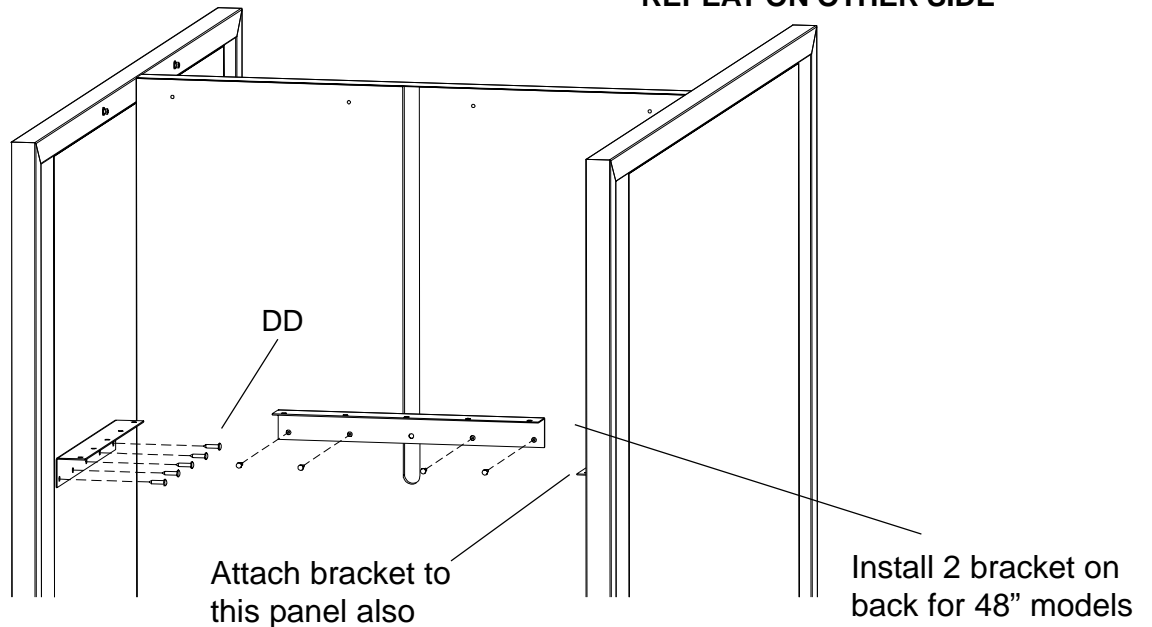

STEP 3

Attach a work surface bracket to each side panel and back panel with screws (DD) as shown. **NOTE:** 48" models have 2 brackets on the back panel.

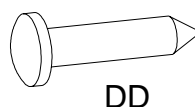

DD

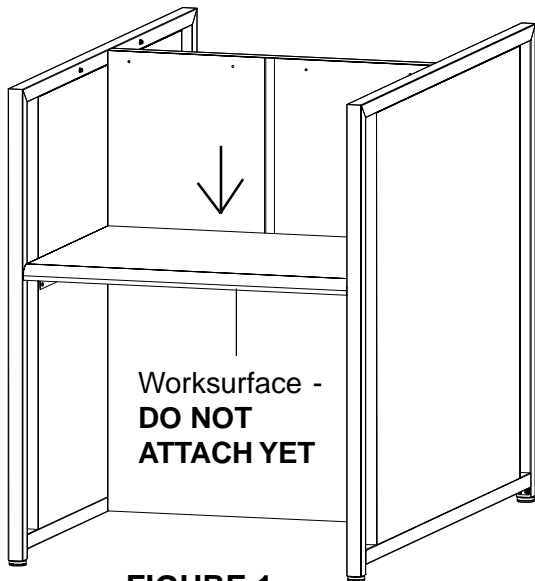

FIGURE 1
REPEAT ON OTHER SIDE

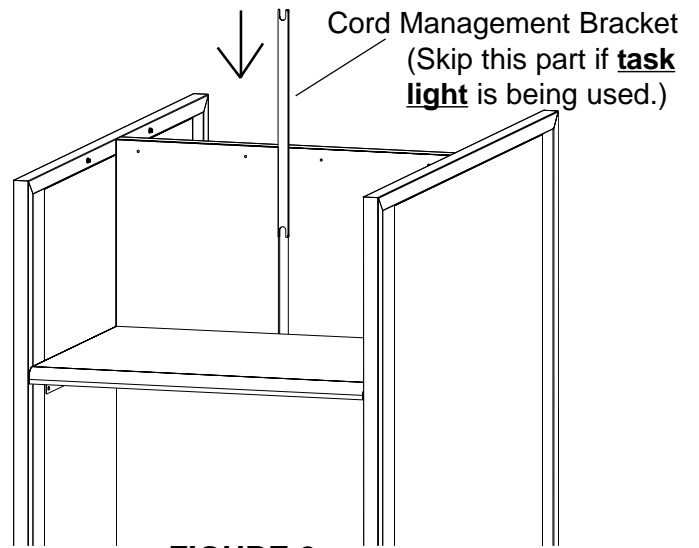

FIGURE 2
REPEAT ON OTHER SIDE

STEP 4

Place worksurfaces onto brackets on both sides of your unit as shown in **FIGURE 1**. **DO NOT SECURE WORKSURFACE AT THIS TIME.** Slide cord management bracket into back panel slot as shown in **FIGURE 2**.

IF YOU ARE INSTALLING A TASK LIGHT REFER TO THOSE INSTRUCTIONS NOW.

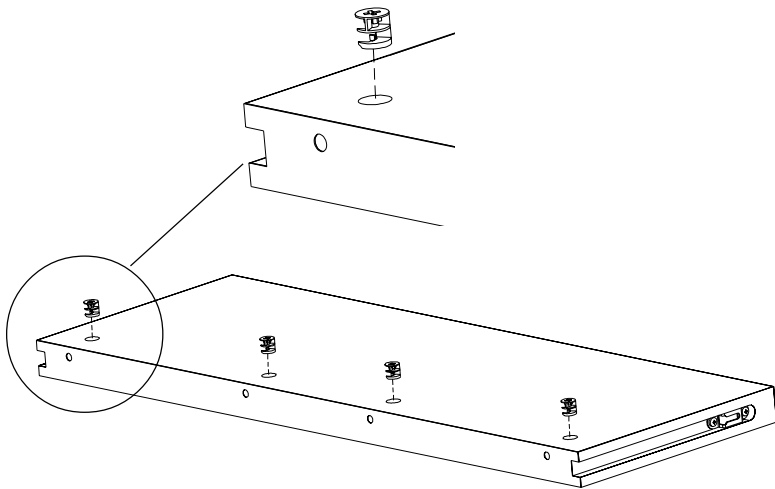

FIGURE 3

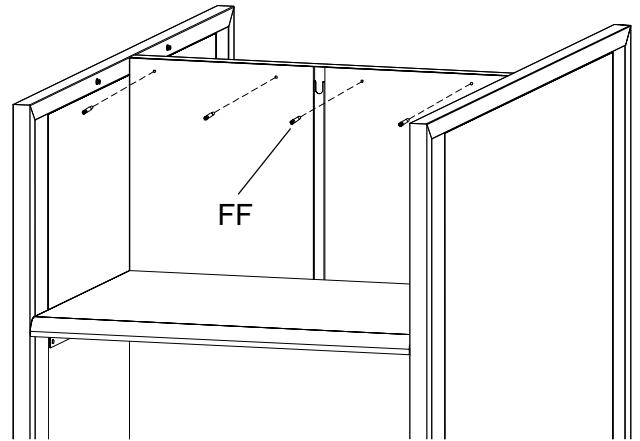
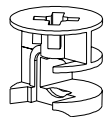

FIGURE 4
REPEAT ON OTHER SIDE

STEP 5

Lay shelf down with holes facing up as shown in **FIGURE 3**. Install minifix cams (EE) into each hole. Install bolts (FF) into the back panel as shown in **FIGURE 4**.



EE

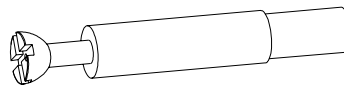

FF

REPEAT ON OTHER SIDE

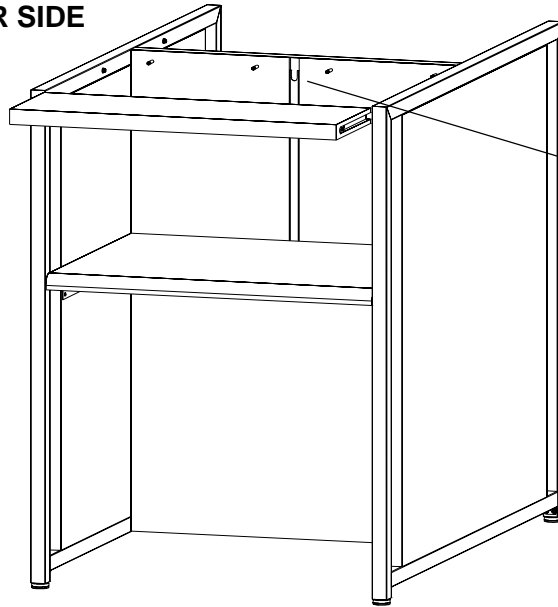

When **task light** is installed, feed cords through slot and slide in cord mangagement bracket before sliding shelf completely in place.

STEP 6

Slide shelf into carrel unit as shown in. Tighten cams from underneath.

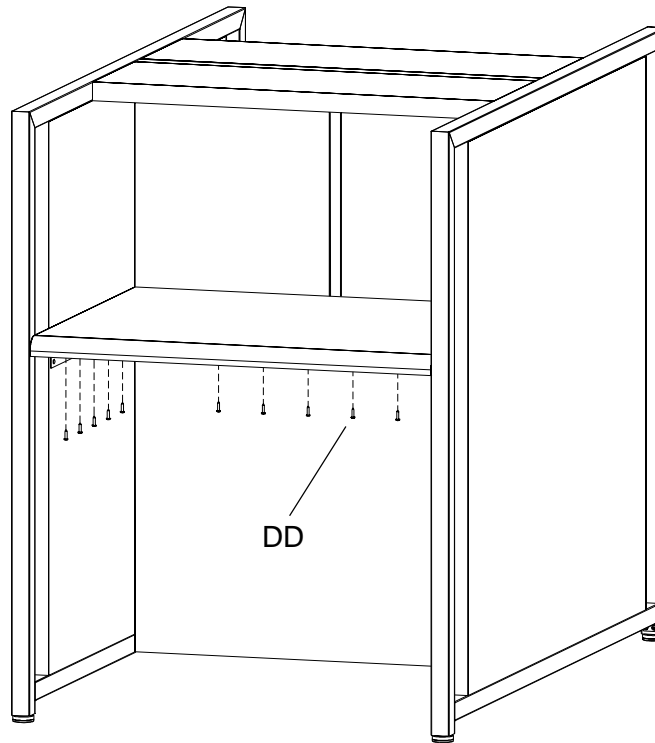

REPEAT ON OTHER SIDE

STEP 7

From underneath, secure the worksurface to the brackets with screws (DD).

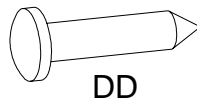

Bretford
11000 Seymour Avenue
Franklin Park, IL 60131
TEL: 847.678.2545
800.521.9614
FAX: 847.678.0852
800.343.1779

Bretford Ltd.
2 Etongate
110 Windsor Road
Slough, Berkshire SL1 2JA England
TEL: 01753 216531
FAX: 01753 539478

www.bretford.com

Part # 031-7223
Rev. 06.13.06 CZ