



BRETFORD™

BRETFORD LIBRARY SYSTEMS

IHC3629CS IHC3629CA

IHC4829CS IHC4829CA

ITHACA

SINGLE FACE CARREL
STARTER AND ADD ON

Assembly Instructions

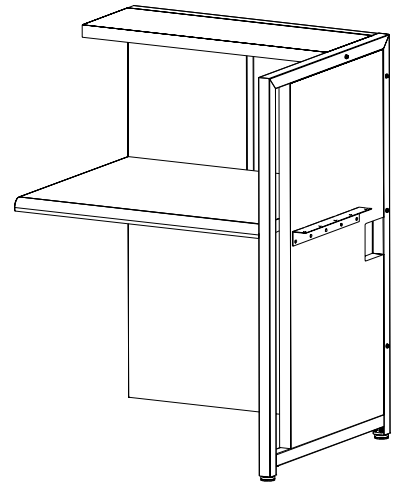
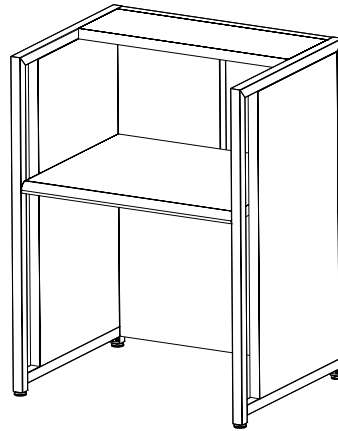

Parts List

Qty.	Description
1	Left Side Panel - Starter Model ONLY
1	Right Side Panel - Starter Model ONLY
1	Middle Panel - Add On Model ONLY
1	Back Panel - All Models
1	Worksurface - All Models
1	Shelf - All Models
1	Cord Management Bracket
3/4*	Worksurface Brackets
	*3629 Models use 3
	*4829 Models use 4

Hardware List

Ref.	Qty.	Part No.	Description
AA	8/10*	030-1146	7/32 x 11mm Modezz Screws
			*3629 Models use 8
			*4829 Models use 10
BB	4/2*	HD1128	1 3/4" X 3/8-16 Floor Glides
			*Starter Models use 4
			*Add On Models use 2
CC	28/40*	030-1148	#8 x 3/4" Phillips Pan Hd Wood Screws
			*3629 Models use 28
			*4829 Models use 40
DD	4	HD1015	MiniFix Cams
EE	4	HD1019	MiniFix Screw Bolts

SAFETY WARNING

**Note: TWO PERSON
ASSEMBLY REQUIRED**

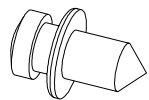
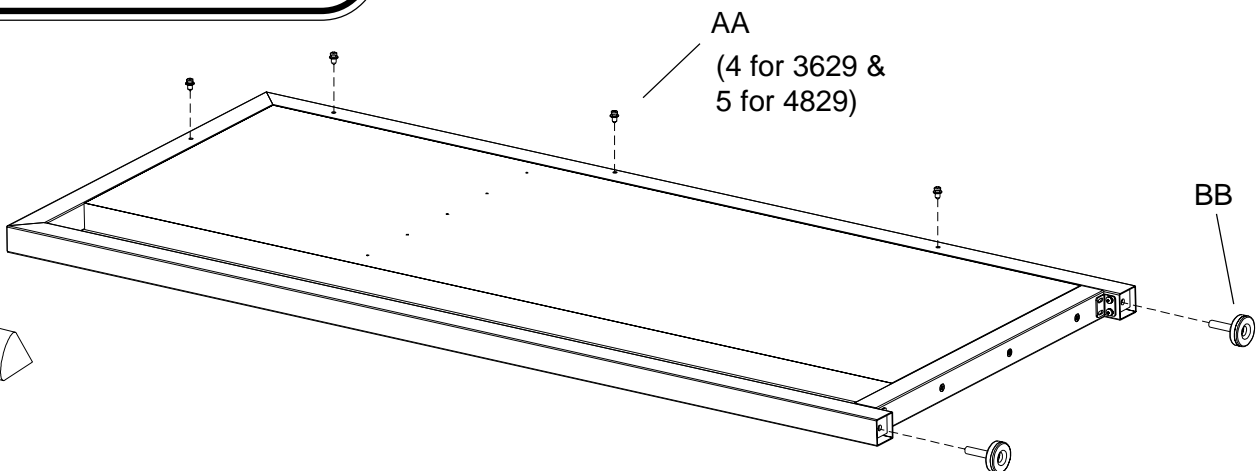

AA

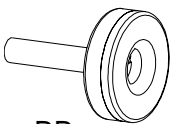

BB

STEP 1

Lay each side panel down with holes facing up as shown. Install modezz screws (AA) into edge holes and glides (BB) into leg bottoms.

NOTE: For middle panels, modezz screws are installed on both sides.

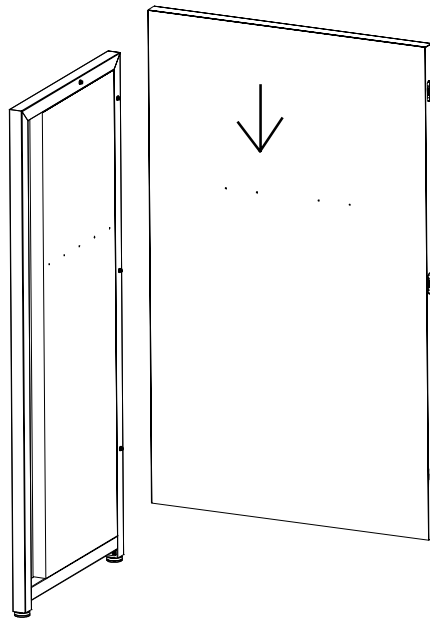

The next panel to install will be an end or middle panel depending on your final layout.

NOTE: If panel does not go down entirely, try backing out the modezz clip screws a 1/4 turn at a time.

STEP 2

With someone's help, attach the back panel to the side by lining up the modezz screw and modezz clip and then sliding into place. Attach the other side panel and/or middle panel in the same manner. **NOTE:** If you are assembling more than one unit, keep installing middle panels. The final end panel will get attached at the end of your row.

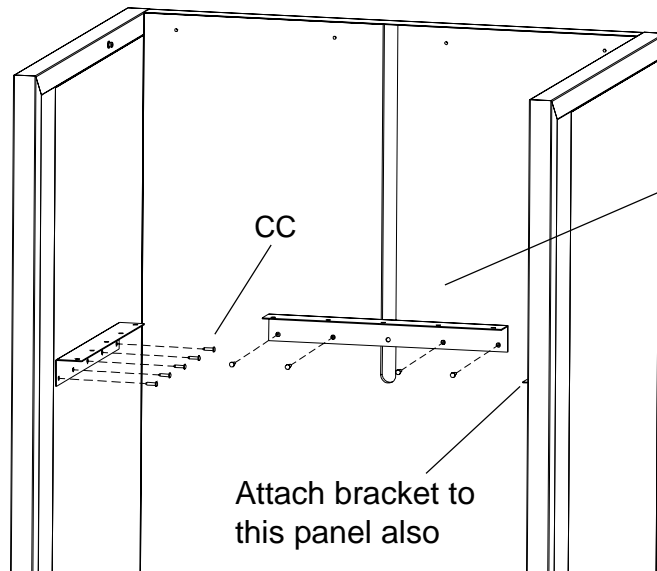

Install 2 bracket on back for 48" models

Attach bracket to this panel also

STEP 3

Attach a work surface bracket to each side panel and back panel with screws (CC) as shown. **NOTE:** 48" models have 2 brackets on the back panel.

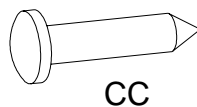

CC

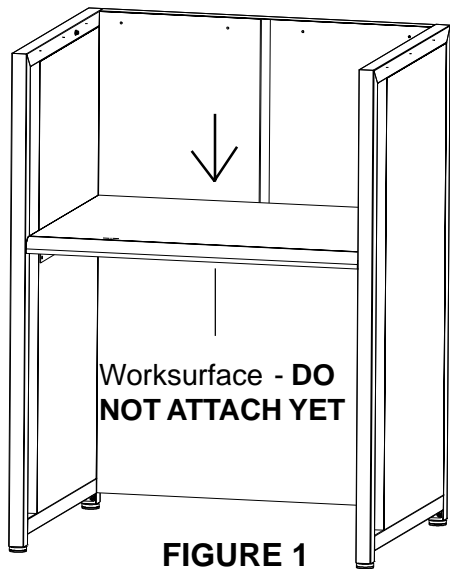

FIGURE 1

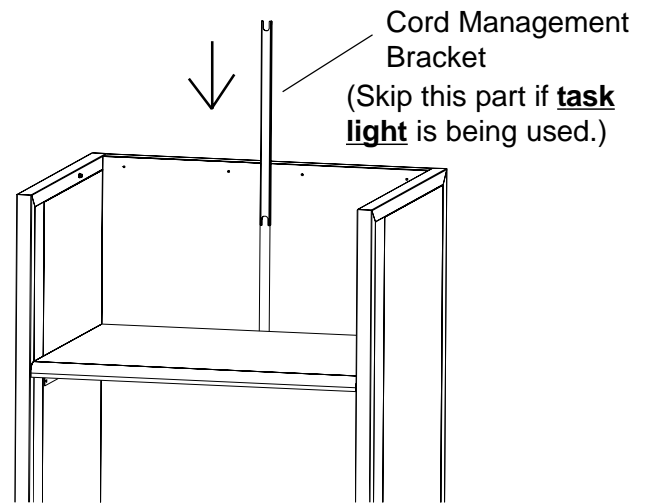

FIGURE 2

STEP 4

Place worksurface onto brackets as shown in **FIGURE 1**. **DO NOT SECURE WORKSURFACE AT THIS TIME**. Slide cord management bracket into back panel slot as shown in **FIGURE 2**.

IF YOU ARE INSTALLING A TASK LIGHT REFER TO THOSE INSTRUCTIONS NOW.

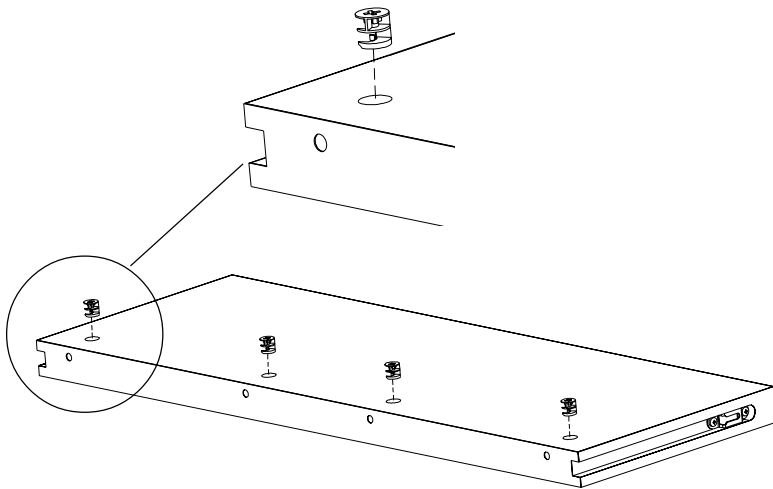

FIGURE 3

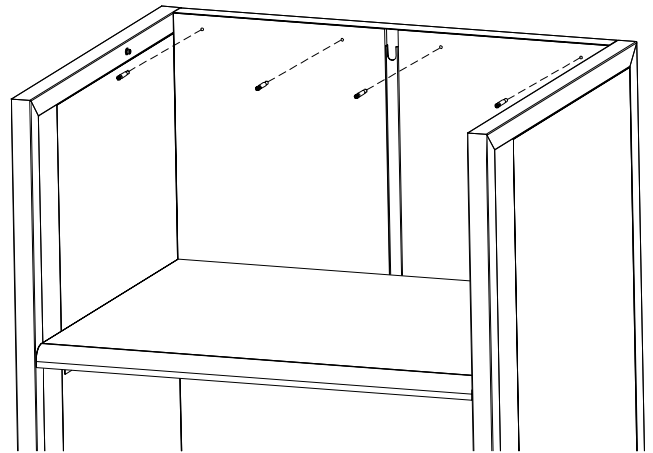
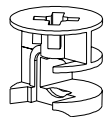

FIGURE 4

STEP 5

Lay shelf down with holes facing up as shown in **FIGURE 3**. Install minifix cams (DD) into each hole. Install bolts (EE) into the back panel as shown in **FIGURE 4**.



DD



EE

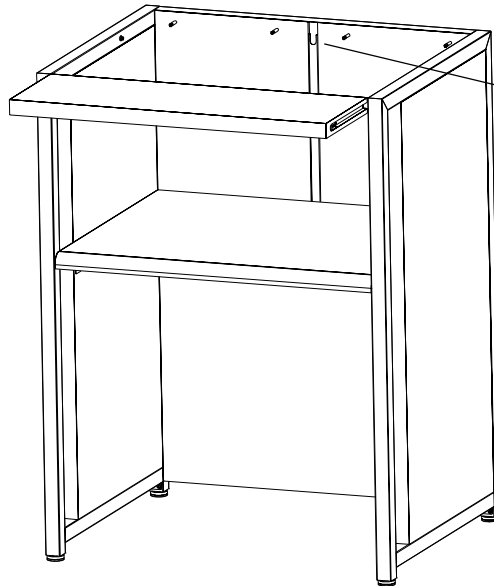

When **task light** is installed, feed cords through slot and slide in cord management bracket before sliding shelf completely in place.

STEP 6

Slide shelf into carrel unit as shown in. Tighten cams from underneath.

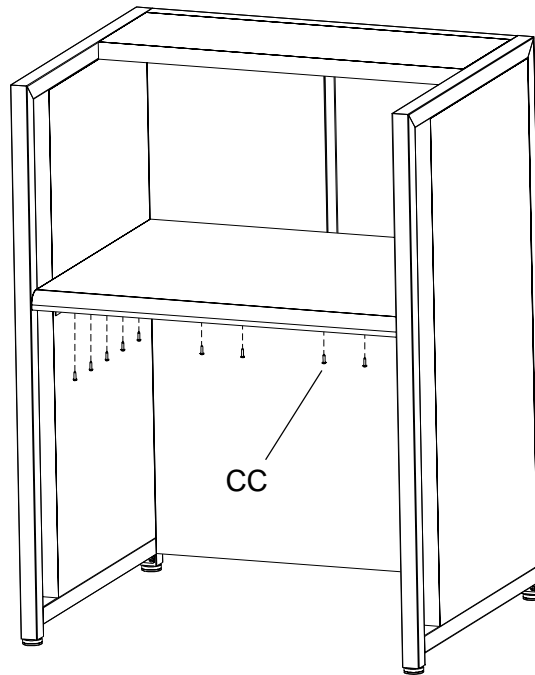

STEP 7

From underneath, secure the worksurface to the brackets with screws (CC).

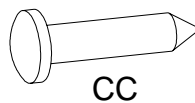

Bretford
11000 Seymour Avenue
Franklin Park, IL 60131
TEL: 847.678.2545
800.521.9614
FAX: 847.678.0852
800.343.1779

Bretford Ltd.
2 Etongate
110 Windsor Road
Slough, Berkshire SL1 2JA England
TEL: 01753 216531
FAX: 01753 539478

www.bretford.com

Part # 031-5827
Rev. 06.12.06 CZ