

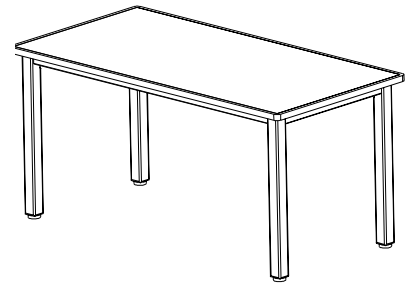

# BRETFORD



## Metal Apron Reading Tables

### Assembly Instructions

#### PARTS LIST

Model	Quantities/Part Numbers/Descriptions		
42DI	(1) SA6392 - 42" Dia Wood Top	(4) 010-3972 - 42" Dia. Skirt	
48DI	(1) SA6393 - 48" Dia Wood Top	(4) 010-3977 - 48" Dia. Skirt	
60DI	(1) SA4536 - 60" Dia Wood Top	(4) 010-4901 - 60" Dia. Skirt	
2436	(1) SA6394 - 24" x 36" Wood Top	(2) 010-3971 - 24" Skirt	(2) 010-3968 - 36" Skirt
3060	(1) SA6395 - 30" x 60" Wood Top	(2) 010-3972 - 30" Skirt	(2) 010-3973 - 60" Skirt
3072	(1) SA4529 - 30" x 72" Wood Top	(2) 010-3972 - 30" Skirt	(2) 010-3974 - 72" Skirt
3648	(1) SA6396 - 36" x 48" Wood Top	(2) 010-3968 - 36" Skirt	(2) 010-3970 - 48" Skirt
3660	(1) SA6397 - 36" x 60" Wood Top	(2) 010-3968 - 36" Skirt	(2) 010-3973 - 60" Skirt
3672	(1) SA6398 - 36" x 72" Wood Top	(2) 010-3968 - 36" Skirt	(2) 010-3974 - 72" Skirt
3690	(1) SA6399 - 36" x 90" Wood Top	(2) 010-3968 - 36" Skirt	(2) 010-3975 - 90" Skirt
4242	(1) SA6400 - 42" x 42" Wood Top	(4) 010-3969 - 42" Skirt	
4260	(1) SA6401 - 42" x 60" Wood Top	(2) 010-3969 - 42" Skirt	(2) 010-3973 - 60" Skirt
4272	(1) SA6402 - 42" x 72" Wood Top	(2) 010-3969 - 42" Skirt	(2) 010-3974 - 72" Skirt
4290	(1) SA6403 - 42" x 90" Wood Top	(2) 010-3969 - 42" Skirt	(2) 010-3975 - 90" Skirt
4848	(1) SA6404 - 48" x 48" Wood Top	(4) 010-3970 - 48" Skirt	
4860	(1) SA6405 - 48" x 60" Wood Top	(2) 010-3970 - 48" Skirt	(2) 010-3973 - 60" Skirt
4872	(1) SA6406 - 48" x 72" Wood Top	(2) 010-3970 - 48" Skirt	(2) 010-3974 - 72" Skirt
4890	(1) SA6407 - 48" x 90" Wood Top	(2) 010-3970 - 48" Skirt	(2) 010-3975 - 90" Skirt
ALL	(4) 010-2371 - Leg Mounting Plate		

#### LEG PARTS LIST

Leg Height	Part No.	Description
J - Juvenile	(4) WM1026	25" Long Leg
Y - Youth	(4) WM1027	26.5" Long Leg
A - Adult	(4) WM1028	29" Long Leg
W - ADA	(4) WM1294	32" Long Leg

#### HARDWARE LIST

Ref	Qty	Part#	Description	Models Used On
AA	4	HD1128	Glides	ALL
BB	8	SC1060	5/16" x 3" Hex Head Bolts	ALL
CC	4	HD1129	5/16"-18 Double Cross Dowels	ALL
DD	12	030-0936	5/16"-18 x 1" Hex Head Screws	ALL
EE	10	030-0304	1/4-20 x 5/8" Combo Screws	2436
	12	030-0304	1/4-20 x 5/8" Combo Screws	42DI, 4242, 48DI & 3072
	14	030-0304	1/4-20 x 5/8" Combo Screws	3648
	16	030-0304	1/4-20 x 5/8" Combo Screws	3060, 3660, 4848, 4260 & 60DI
	18	030-0304	1/4-20 x 5/8" Combo Screws	3672 & 4272
	20	030-0304	1/4-20 x 5/8" Combo Screws	3690, 4290, 4860 & 4872
	22	030-0304	1/4-20 x 5/8" Combo Screws	4890

#### Tools Required

Adjustable Wrench  
Phillips Screwdriver  
Flat Screwdriver

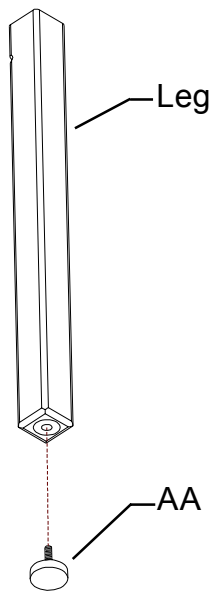

**STEP 1**

Fully install glides (AA) on the bottom of each leg by turning clockwise.

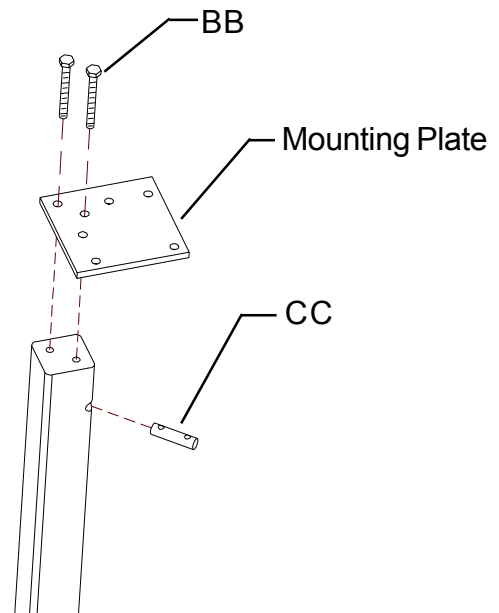

**STEP 2**

Insert dowel (CC) into hole in leg. Adjust so that slot in dowel is vertical. **\*\*Attach mounting plate to top of leg with two bolts (BB) and lock bolts into dowel. Repeat for each leg.**

**\*\*NOTE:** Mounting plates are loosely attached to the table top. **DO NOT THROW AWAY SCREWS YOU REMOVED.** You will use the in Step 3

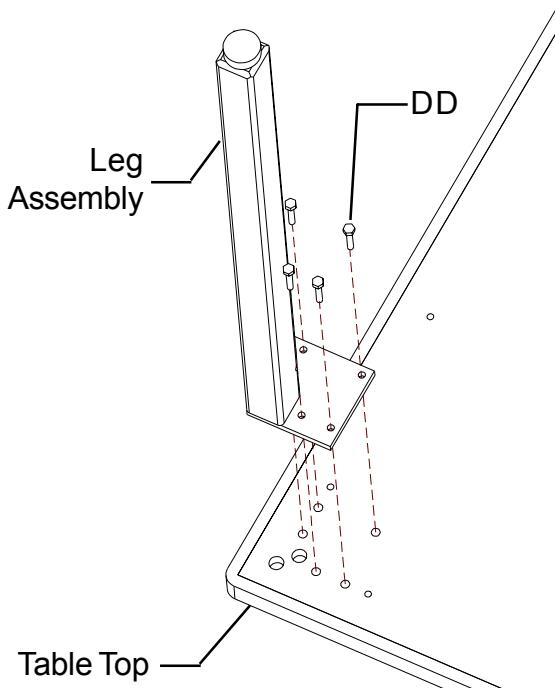

**STEP 3**

Attach leg assembly to table top using (5) screws (DD). Repeat for each leg assembly.

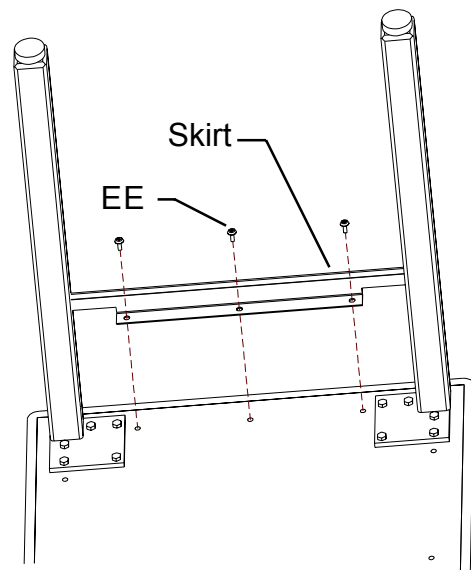

**STEP 4**

Attach skirt to table top using Screws (EE). Repeat for each side of table top.

**Bretford**  
 11000 Seymour Avenue  
 Franklin Park, IL 60131  
 TEL: 847.678.2545  
 800.521.9614  
 FAX: 847.678.0852  
 800.343.1779

**Bretford Manufacturing Ltd.**  
 2 Etongate  
 110 Windsor Road, Slough  
 Berkshire SL1 2JA England  
 TEL: 01753 539955  
 FAX: 01753 539478