



BRETFORD™

**SAN FRANCISCO CIRCULATION DESK
NARROW / WIDE CABINET DOOR
Assembly Instructions**

Parts List

Qty.	Description
1	Door Stop Panel
1	Door Panel

Hardware List

Ref.	Qty.	Part No.	Description
AA	8	HD1023	5mm Diameter Expanding Bushings
BB	4	030-0298	#8 x 3/8" Phillips Truss Hd Screws
CC	2	HD1093	H-Series Hinges
DD	8/10*	SC1056	#6 x 5/8" Pan Head Screws *Models w/o a lock use 8 Models with a lock use 10
EE	2	012-0746	Hinge Hole Covers
FF	2	HD1094	Hinge Mounting Plates
GG	1	030-0844	Bow Handle
HH	2	030-0845	5 x 14 Handle Screws
Models With Locks			
II	1	HD1137	Lock Core
JJ	1	HD1251	Lock Body

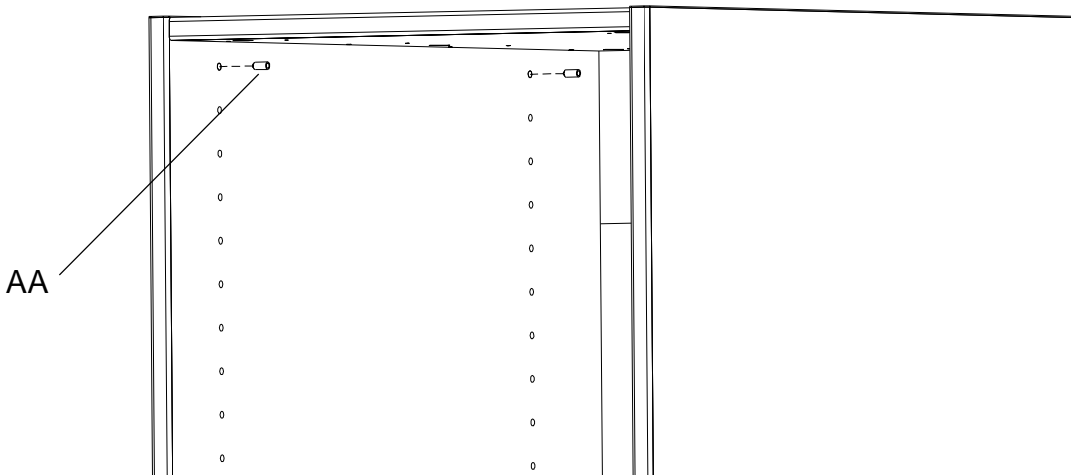

STEP 1

Install bushing (AA) into the top holes of each side panel as shown.

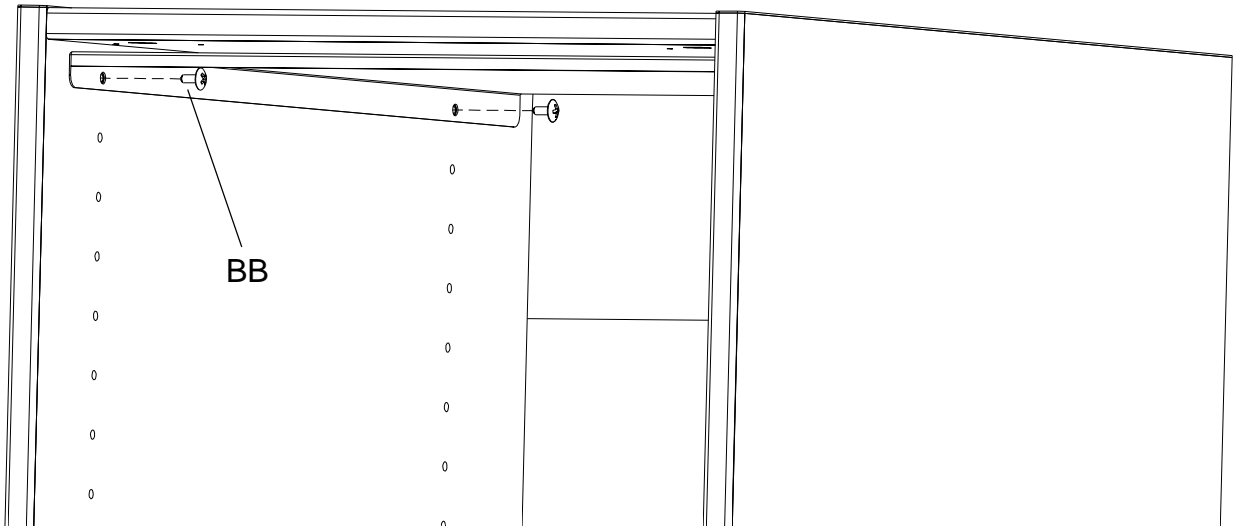

STEP 2

Install door stop panel through top holes using screws (BB) as shown.

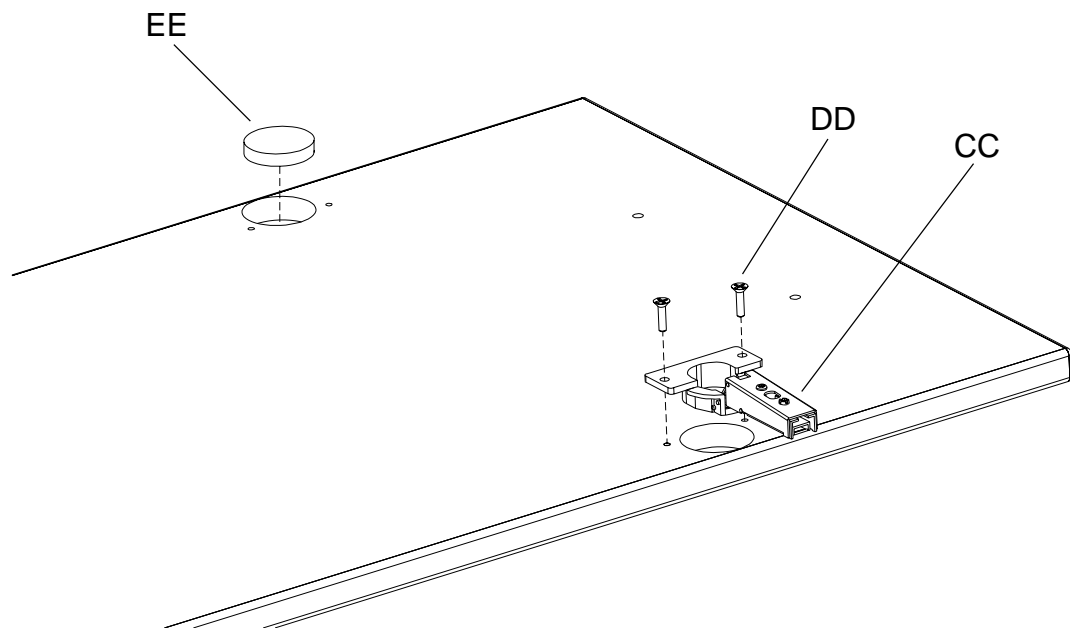

STEP 3

Determine which side the door will open on. Then install hinge (CC) with screws (DD) and install hinge cover (EE) into opposite holes as shown.

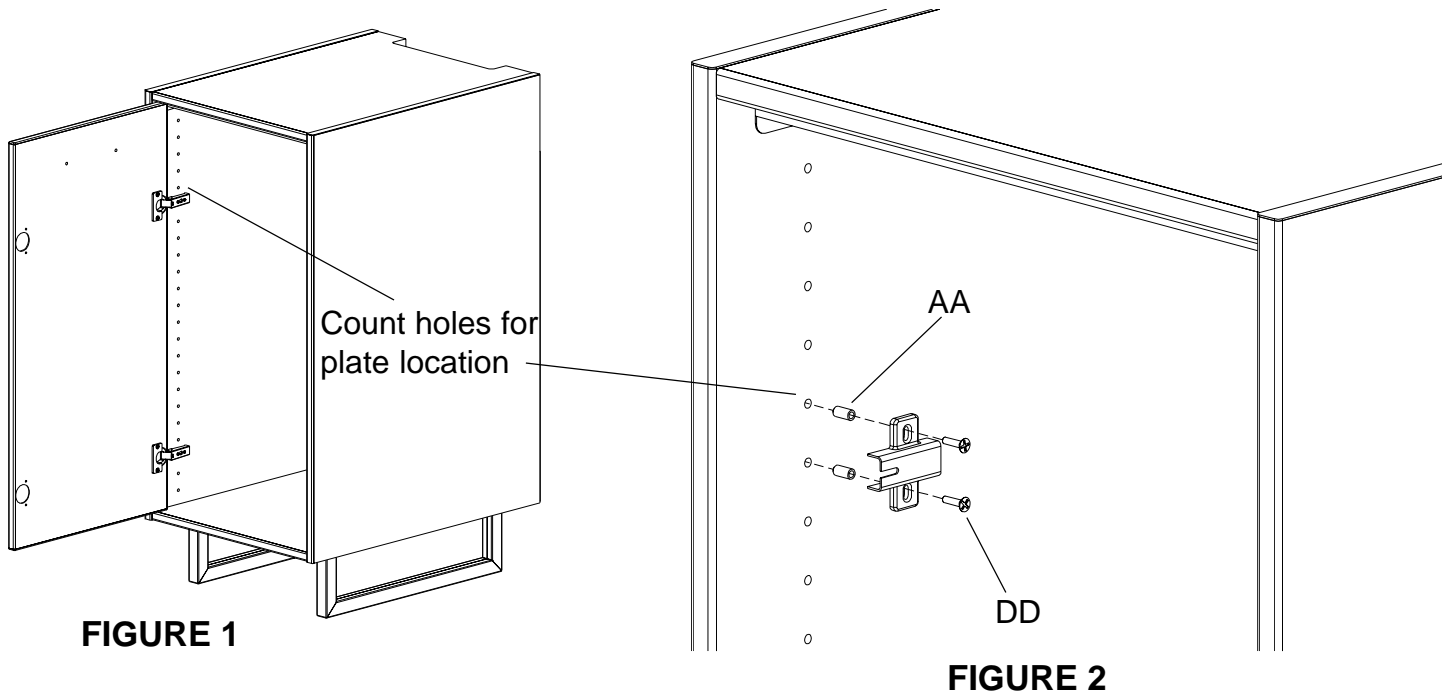
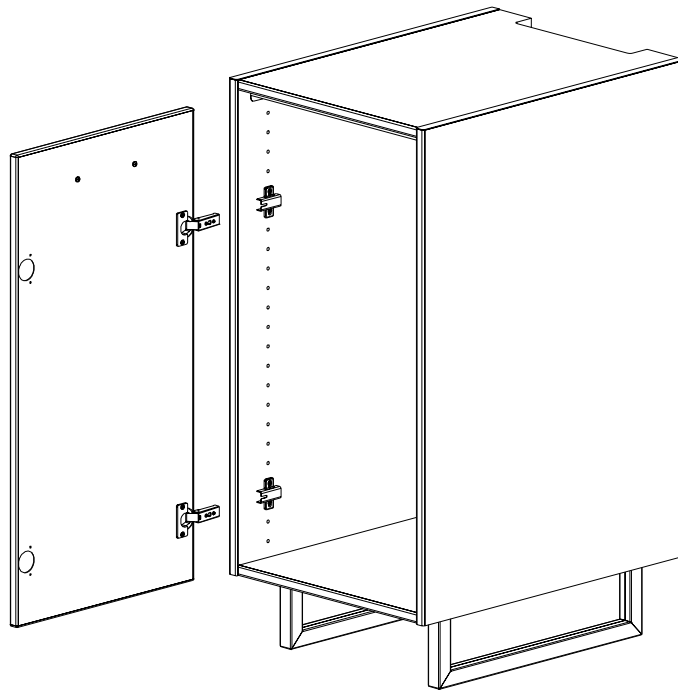

FIGURE 1

FIGURE 2

STEP 4

First, align door panel in shell unit. Reference **FIGURE 1**. Note the hole locations above and below the hinges. Install bushing (AA) into each hole and attach plate with screws (DD) as shown in **FIGURE 2**.



STEP 5

Install door so that the hinges slide over the plates. Make sure that the screw in the plate slides into the groove in the hinge.

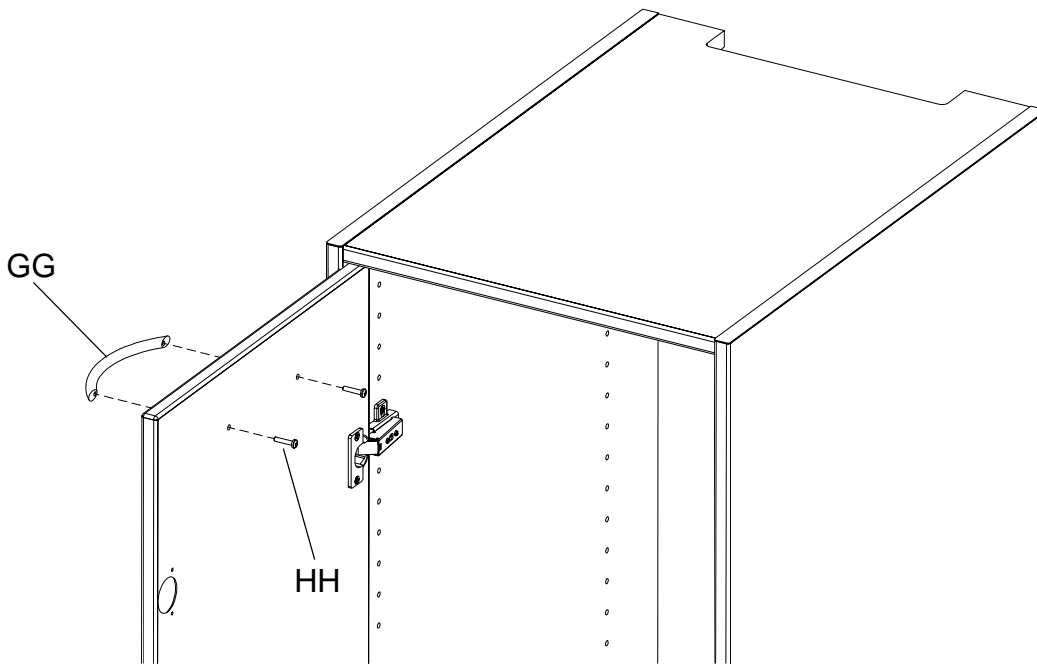

STEP 6

Install handle (GG) with screws (HH) as shown.

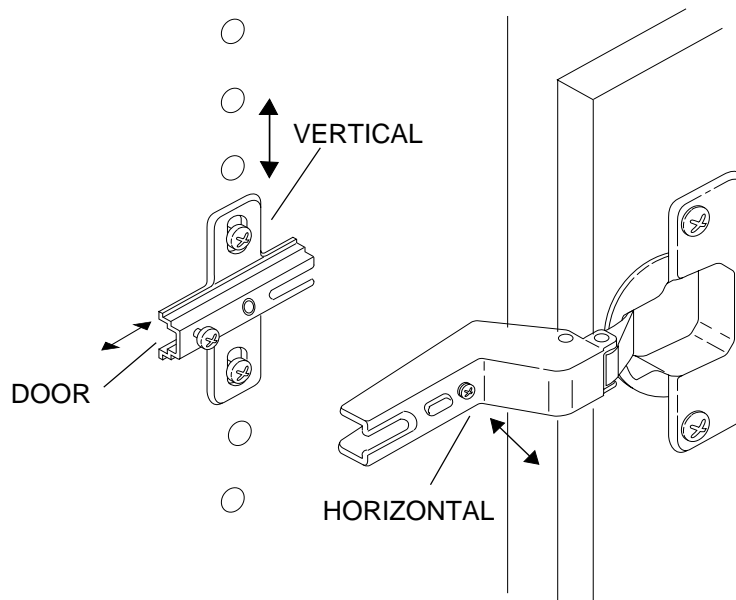

ADJUSTMENTS

Adjust the hinges as necessary to make sure the door meets properly with shell unit. This illustration indicates which screws have which effect on the door panel.

Bretford
 11000 Seymour Avenue
 Franklin Park, IL 60131
 TEL: 847.678.2545
 800.521.9614
 FAX: 847.678.0852
 800.343.1779

Bretford Ltd.
 2 Etogate
 110 Windsor Road, Slough
 Berkshire SL1 2JA England
 TEL: 011 44 17 5353 9955
 FAX: 011 44 17 5353 9478

www.bretford.com

Part # 031-5725
 09.05.06 CZ