

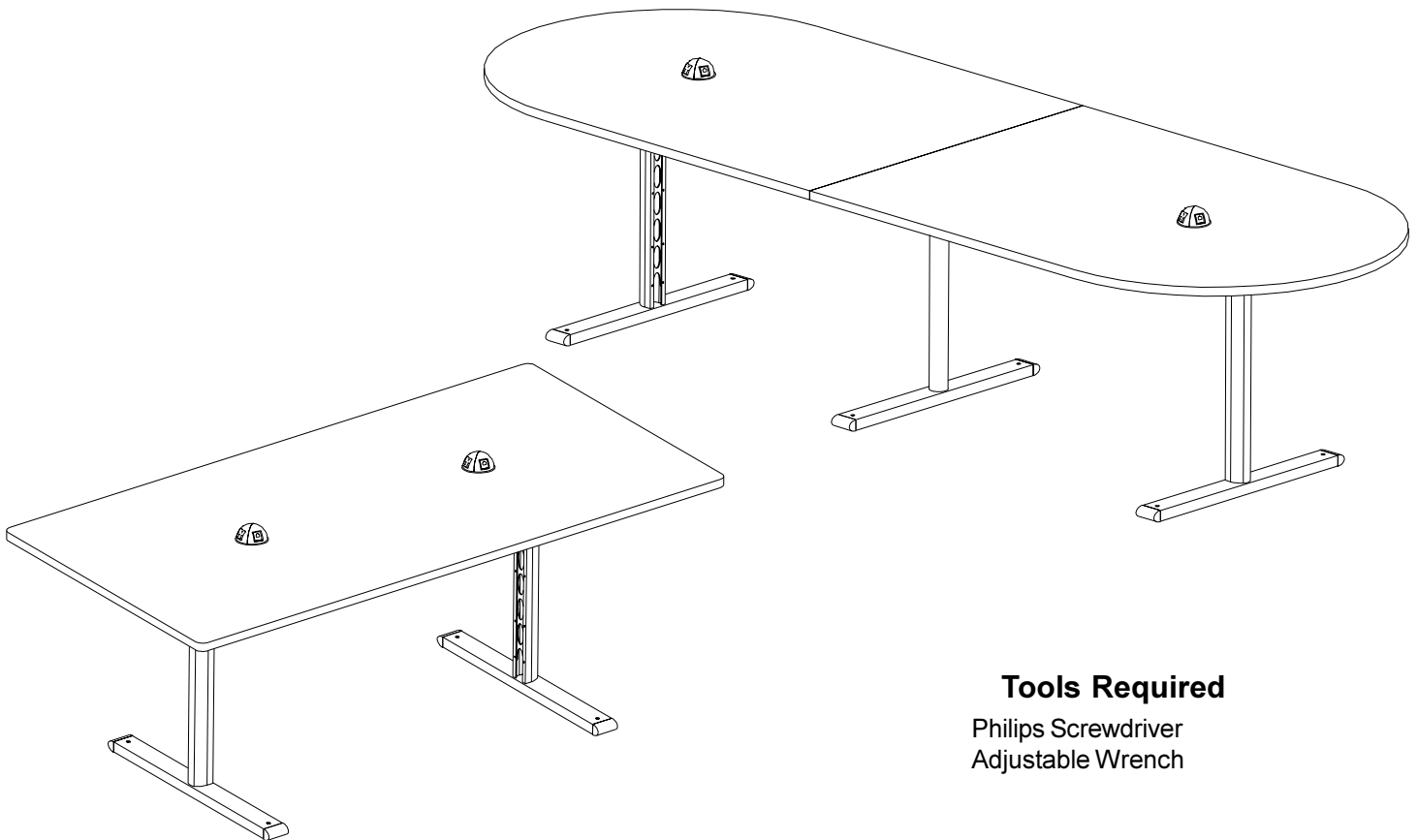

BRETFORD

CONFERENCE TABLES WITH POWER/DATA SPHERE (Optional) OR POWER/POWER SPHERE (Optional) Assembly Instructions



Tools Required

Philips Screwdriver
Adjustable Wrench

PARTS LIST

1	022-1873	Right Leg Assembly	24
1	022-1871	Left Leg Assembly	
1	022-2192	Middle leg Assembly (120" Long Tables)	
2	010-2800	34" Long Stiffener (72" Long Table)	24
2	010-3533	84" Long Stiffener (96" Long Table)	2
2	010-2464	52" Long Stiffener (120" Long Table)	16
1	SA5919- SA5930	Top (Right & Left for 120" Long Tables)	
2	RDOME22	Power/Data Sphere (Optional)	
2	RDOME40	Power/Power Sphere (Optional)	

HARDWARE LIST

030-0304	1/4-20 x 5/8" Combo Truss Screws (Including 16 for 96" & 72" Long Tables)
030-0259	#10 x 1/2" Phillips Pan Screws
030-0537	Tie-joint (for 120" Long Tables)
030-0453	#12 x 3/4" Phillips Truss Head

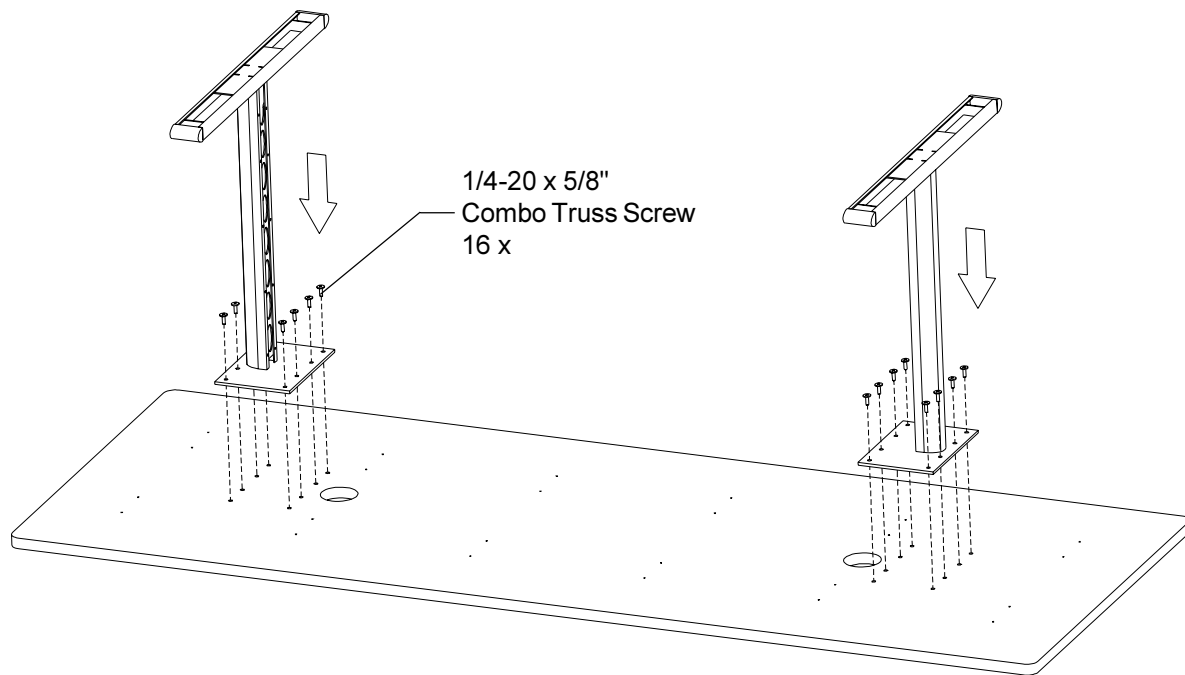

STEP 1

Lay the wood top down with holes facing up as shown. Attach each leg to the wood top with the 1/4-20 x 5/8" screws as shown. Make sure the ellipses on each leg face in as shown. **Tighten all screws.**

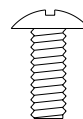

SAFETY WARNING
Note: TWO PERSON
ASSEMBLY REQUIRED

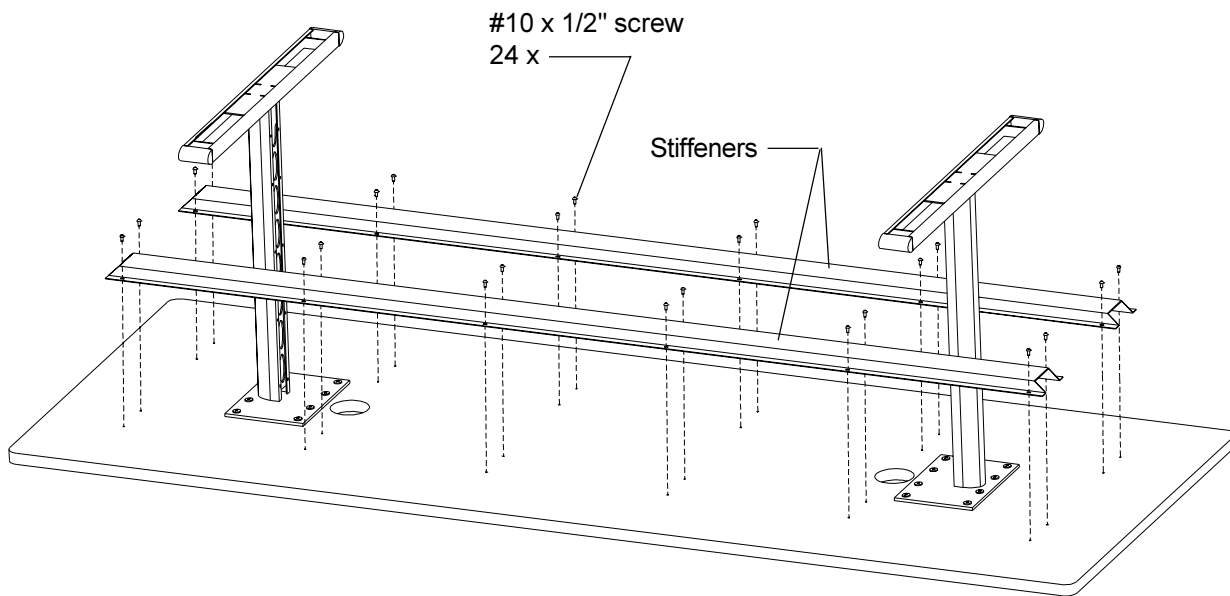

STEP 2

Position the table stiffener over holes and attach in place with the #10 x 1/2" screws as shown. **Tighten all screws.**
 Turn unit over, position and adjust glides to floor.

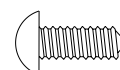

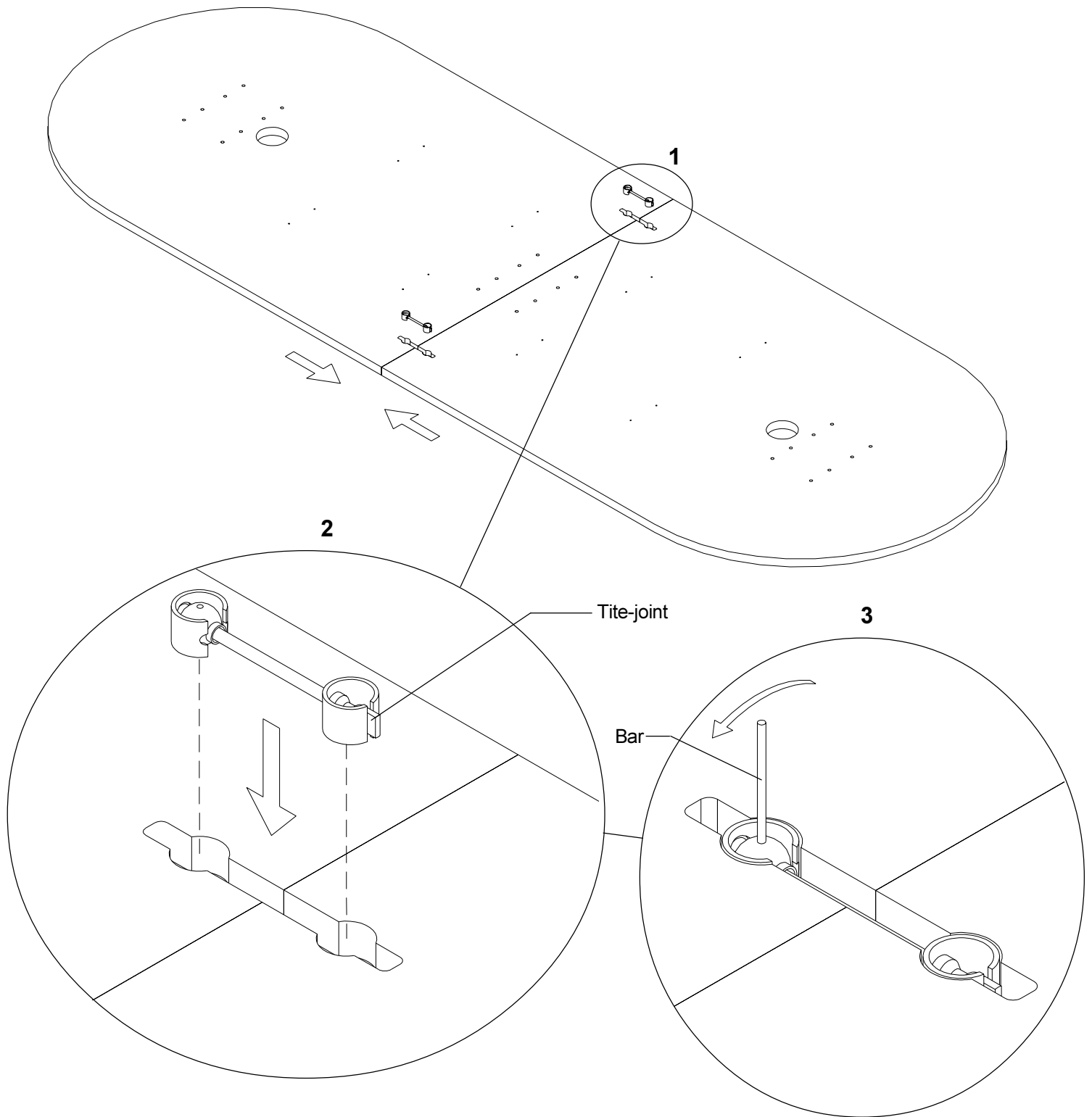

STEP 3
(For 120" Long Tables Only)

1. Lay the wood tops down with holes facing up as shown. Slide both halves together until edges are aligned.
2. Take two tite-joint connectors and insert them into two slots as shown.
3. Using small bar rotate the ball counter-clockwise until both halves of table are securely drawn together.

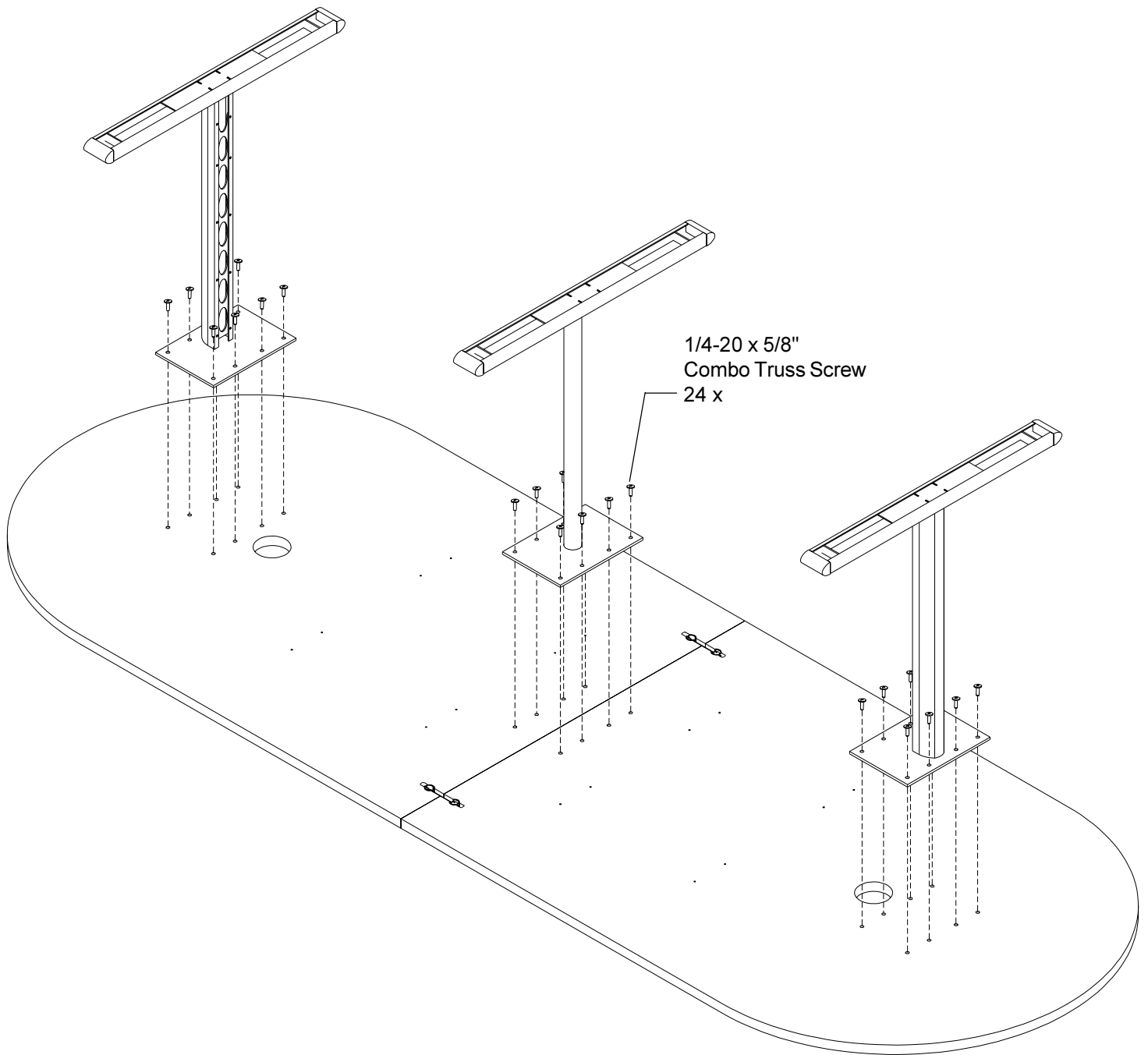

STEP 4

Attach each leg to the wood top with the 1/4-20 x 5/8" screws as shown. Make sure the ellipses on each leg face as shown. **Tighten all screws.**

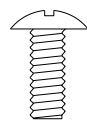

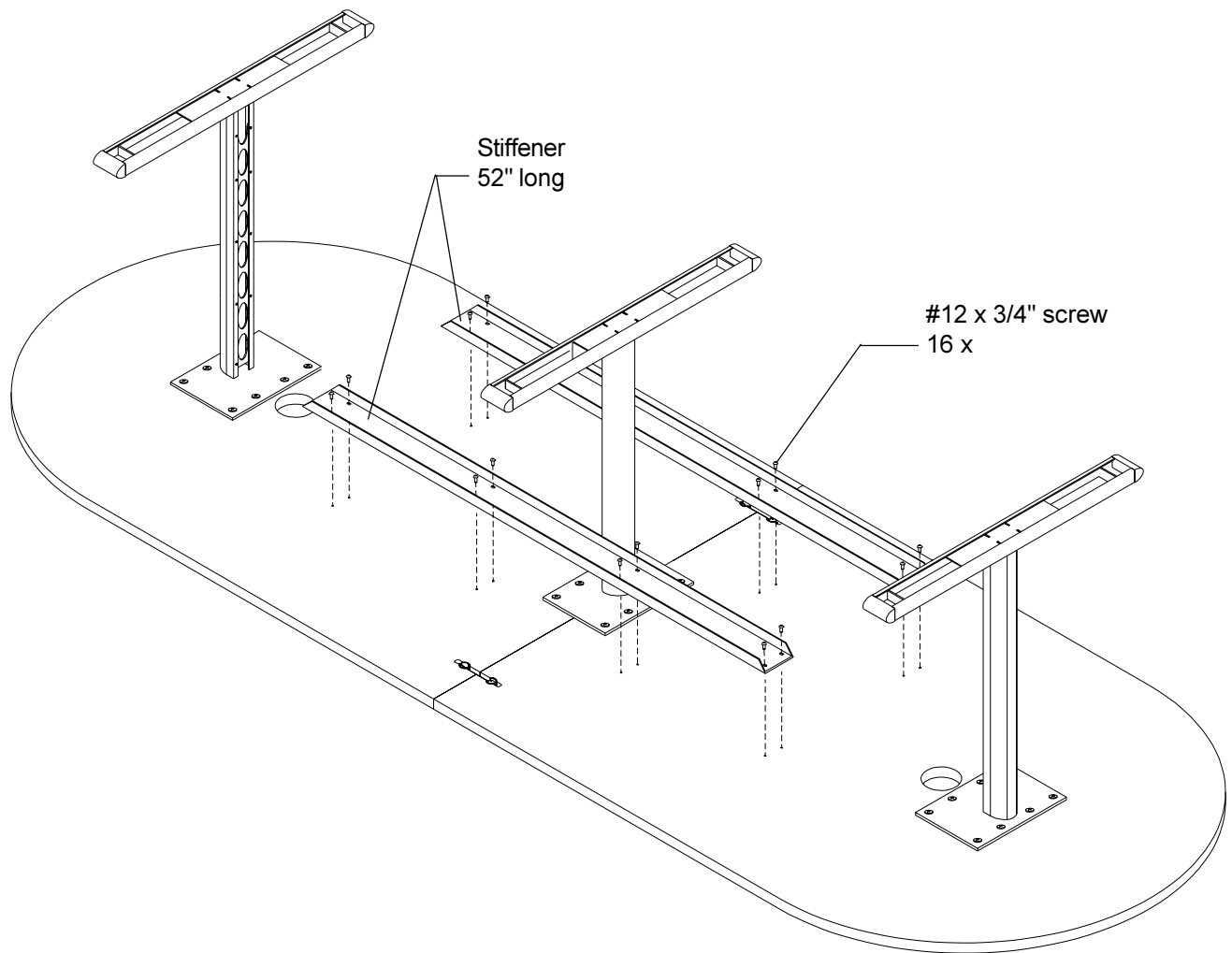

STEP 5

Position the table stiffener over holes and attach in place with the #10 x 1/2" screws as shown. **Tighten all screws.**

Turn unit over, position and adjust glides to floor.

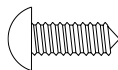

NOTE: See step #6 for installation of optional power/data sphere or power/power sphere.

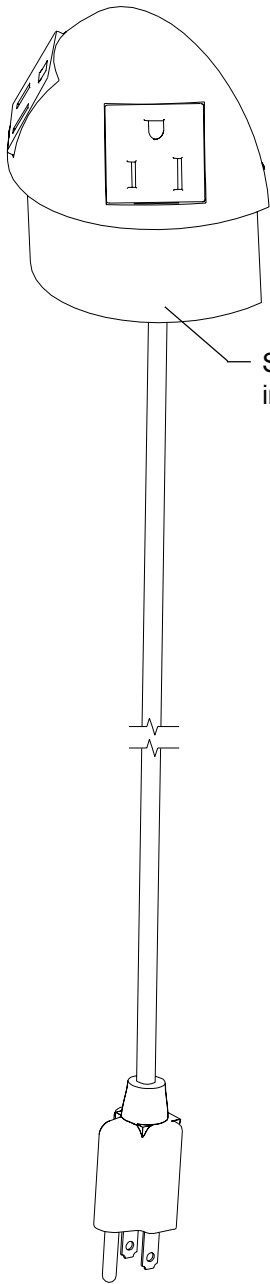
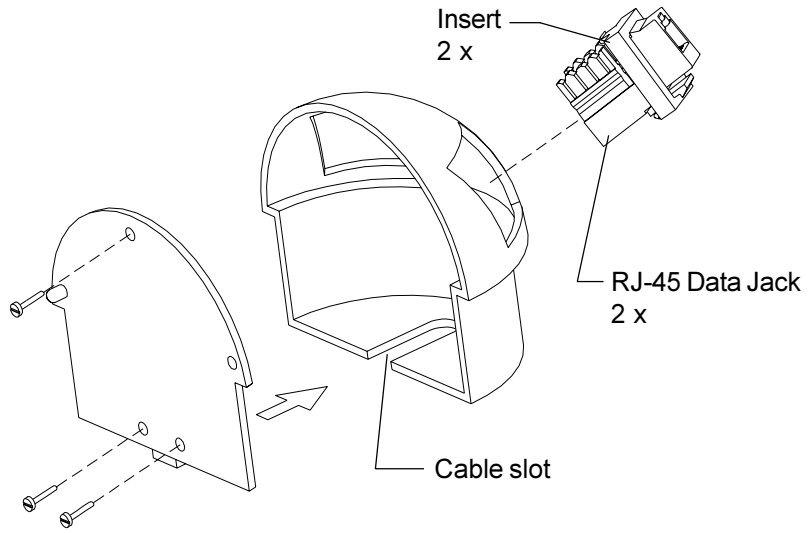

STEP 6

Upon receiving Power/Data Sphere Power half of sphere is ready to install. Other half will require some assembly. End user will be responsible for wiring Data Jack. After wiring is completed you can take insert & Data Jack and insert into data half as shown until it locks. With data wire aligned in cable slot, attach rear panel onto data sphere half as shown. Attach the two halves together.

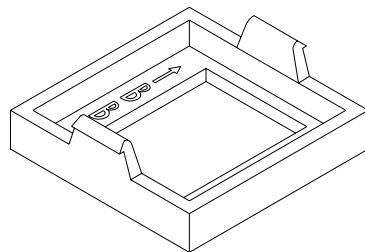
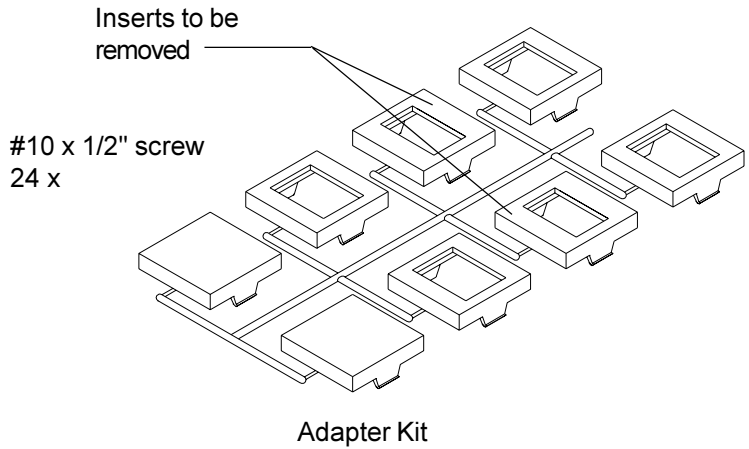

Insert

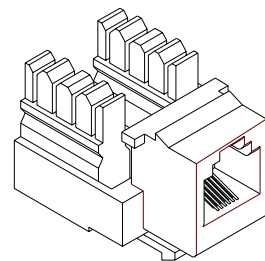

RJ-45 Data Jack

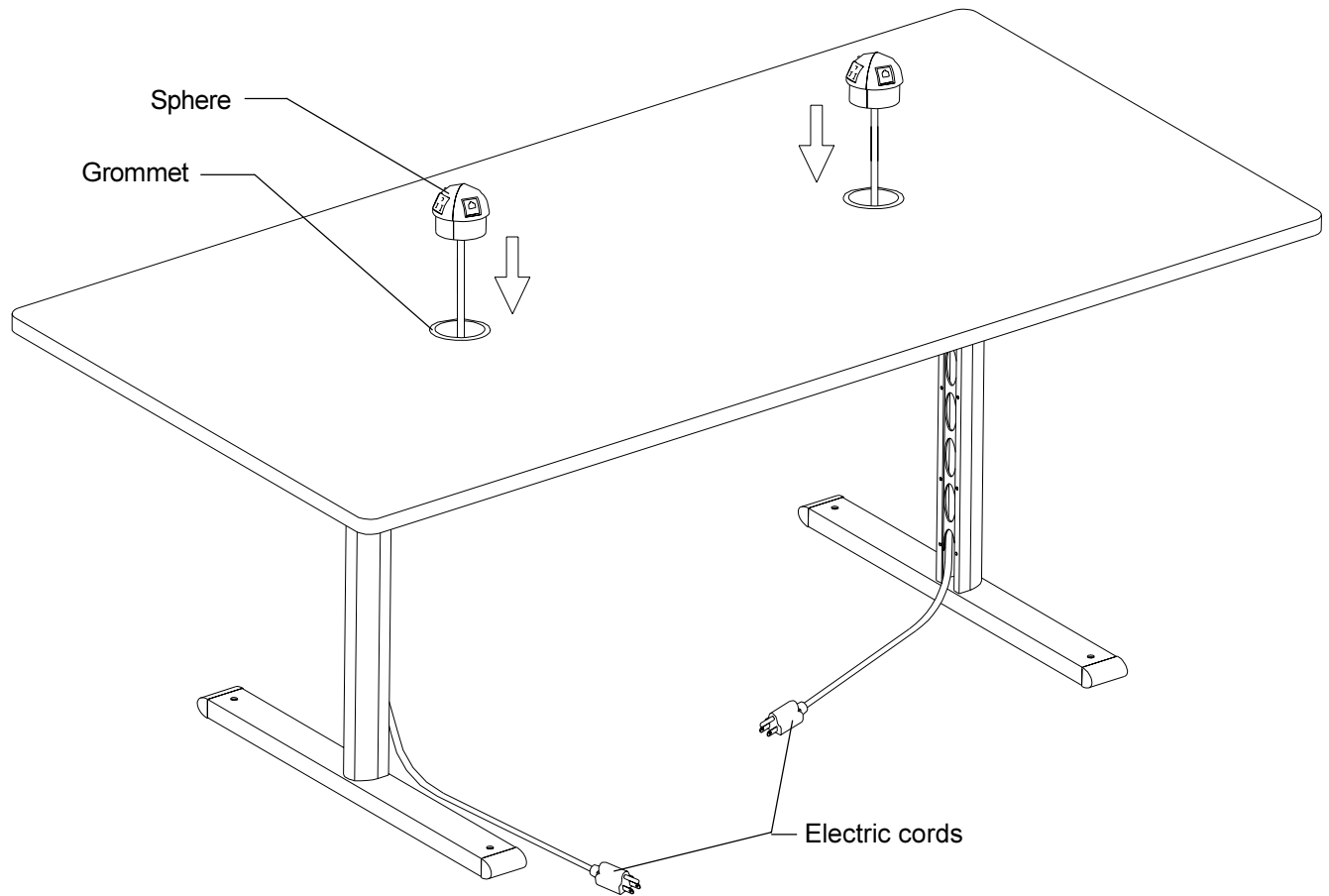

STEP 7

Upon receiving this product the grommets will be already installed in table top. Take electric cords and pull them thru the holes at the top and further thru leg openings.

Install the E-unit into the grommet using mallet (if necessary). The E-unit should be fully seated so entire stem is inside of grommet.

Once your table is in position, it might be necessary to level it. Determine which leg is rocking and using straight blade screwdriver, turn the glide up or down to level.

Bretford
11000 Seymour Avenue
Franklin Park, IL 60131
TEL: 847.678.2545
800.521.9614
FAX: 847.678.0852
800.343.1779

Bretford Ltd.
Technology House
7 Lake End Court, Taplow
Bucks SL6 0JQ England
TEL: 01628 603558
FAX: 01628 604923

Part#031-4433
Rev.02.27.02 IM