

SPA900TBL SPA900TBR
 SPG910TBL SPG910TBR

PLUS CHAIRS WITH TABLET ARM

Assembly Instructions

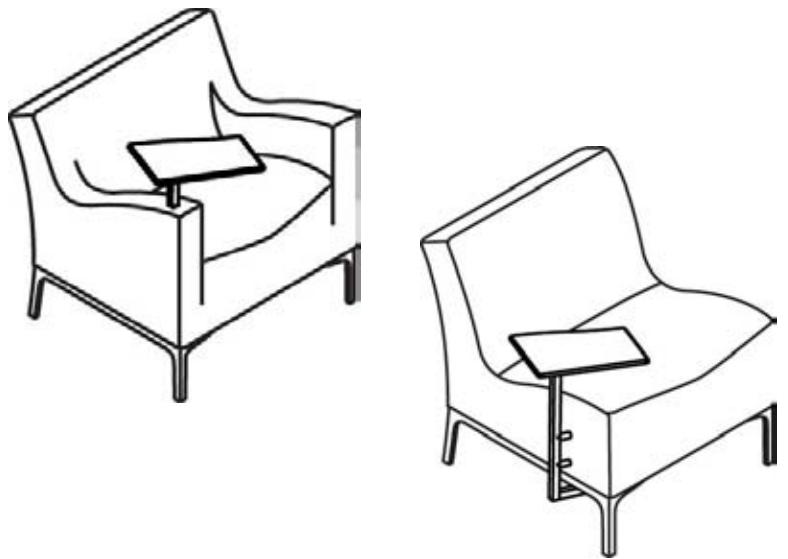

PARTS LIST

Qty.	Description
1	Chair with Tablet Base
1	Right Leg with Caster
1	Left Leg with Caster
1	Wood Tablet Top

HARDWARE LIST

Ref.	Qty	Part #	Description
AA	1	022-2705	Top Plate Assembly
BB	4	030-0945	1/4-20 x 1" Flat Hd Phillips Screws
CC	1	012-0813	Black Plastic Grommet
DD	10	030-1300	#10 x 1 1/4" Pan Hd Wood Screws
EE	1	030-0305	7/8" x 17/64" x 1/16" Washer
FF	2	010-3380	1.523" Nylon Washer
GG	1	030-0733	1/4-20 Center Grip Lock Nut

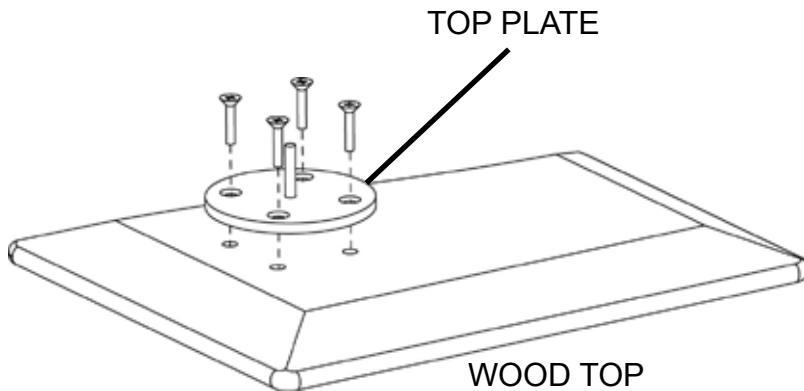

STEP 1

Install top plate (AA) to wood top using screws (BB) as shown.

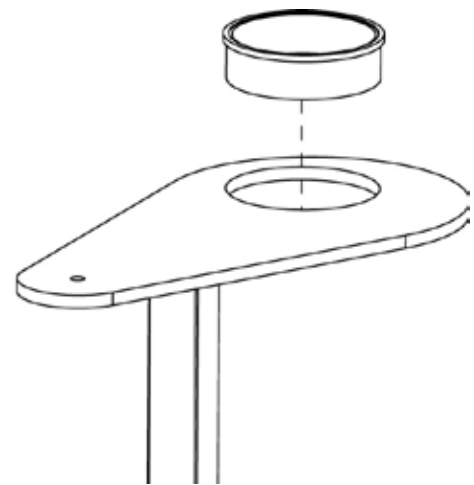

STEP 2

Snap grommet (CC) into base hole as shown.



CHAIR BACK

FIGURE 1

CHAIR FRONT

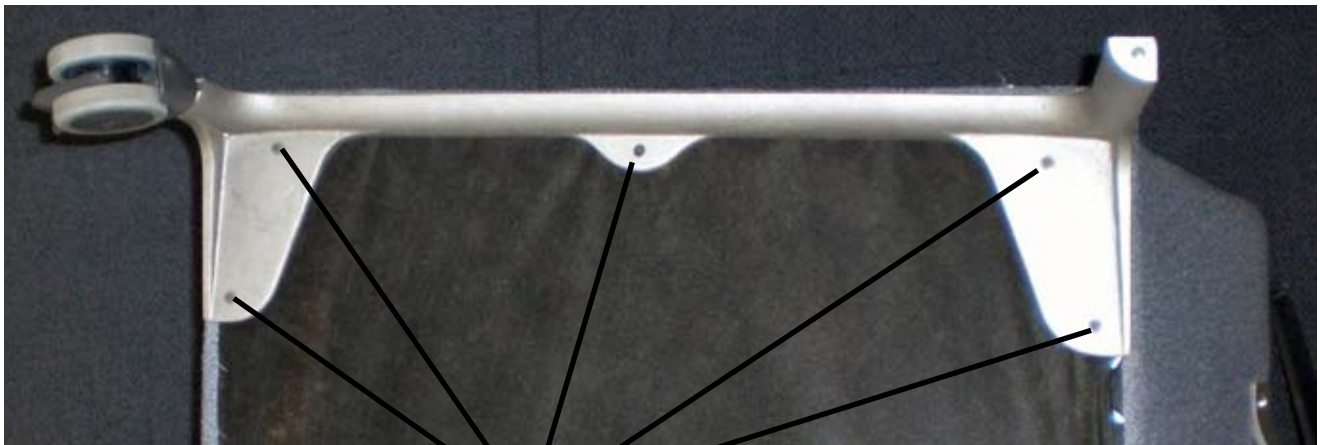

FIGURE 2

INSTALL 5 SCREWS
PER SIDE

STEP 3

Turn chair over and position each leg as shown in **FIGURE 1**. Install each leg with screws (DD), 5 per side as shown in **FIGURE 2**. Make sure casters are facing the front of the chair. **NOTE:** For armless chairs, refer to **FIGURE 3**. Remove bolt and spacer first, then slide leg in place secure and then replace spacer and bolt.



FIGURE 3

PRIOR TO INSTALLING
LEG, REMOVE BOLT AND
SPACER. REPLACE AFTER
INSTALLING LEG.

STRAIGHT EDGE FACES THE
INTERIOR OF THE CHAIR

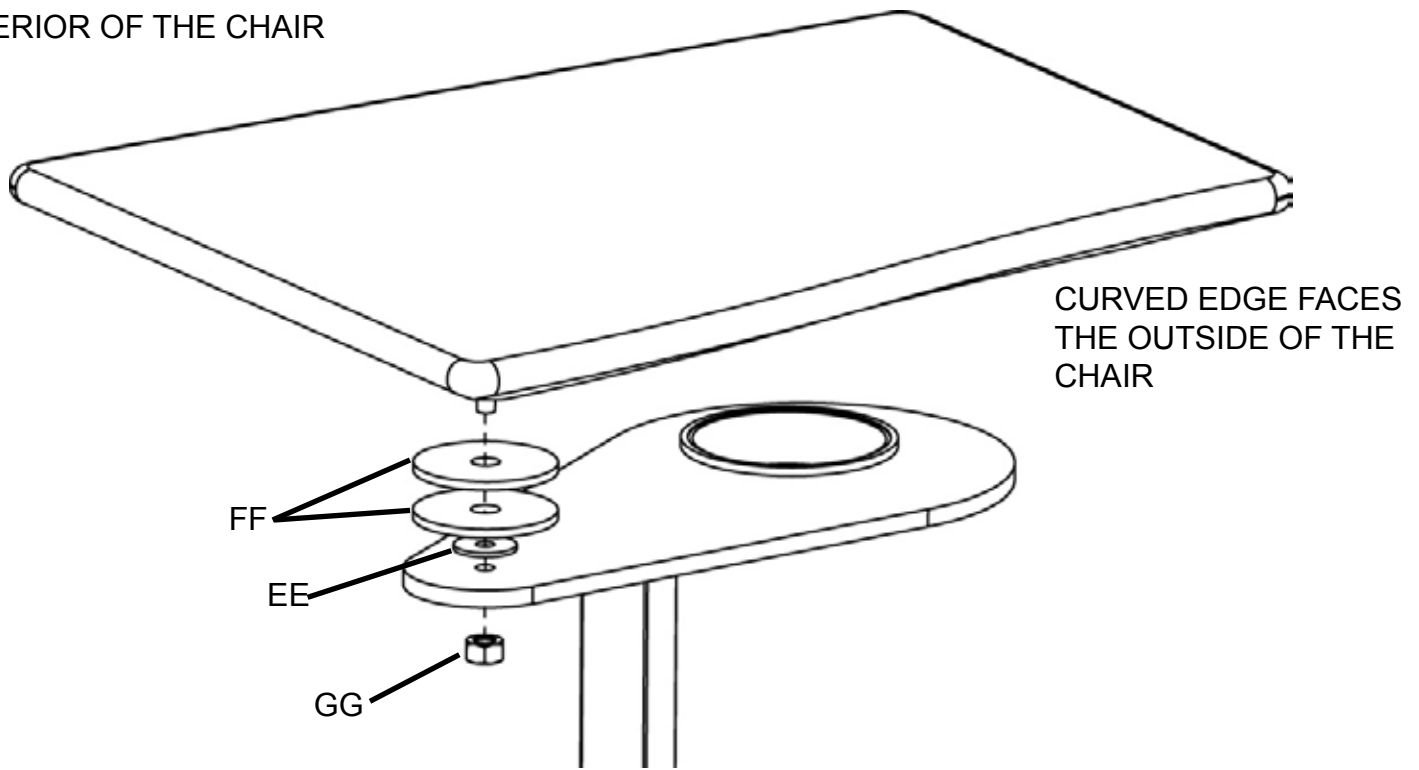

STEP 4

Turn chair over and install wood top as shown. Stack washers (EE) and (FF) on base plate, then slide on wood top and secure together using nut (GG).

NOTE: When installing wood top, make sure the curved side is facing the outside of the chair. The straight edge of the top should face the interior of the chair. Once the top is secure, the curved edge will rotate to face the user.

Bretford
11000 Seymour Avenue
Franklin Park, IL 60131
TEL: 847.678.2545
800.521.9614
FAX: 847.678.0852
800.343.1779

Bretford Ltd.
2 Etongate
110 Windsor Road, Slough
Berkshire SL1 2JA England
TEL: 011 44 17 5353 9955
FAX: 011 44 17 5353 9478