



BRETFORD

PRESENTATION ENVIRONMENTS®

ROUND AND SQUARE TABLES

With POWER/DATA

Assembly Instructions

PARTS LIST

Qty	Description
1	Base Assembly
1	Upright Assembly
1	Wood Top
1	Plate Mounting
3	Cover Panel
1	Cover Panel w/Cable Cutout
1	Power mount plate
1	Jack mount plate
1	E-unit
4	Data Jack

HARDWARE LIST

Qty	Description
12	1/4-20 x 5/8" Truss Screws
8	5/16-18 x 1-1/2" Hex Screws
8	Spacers
4	Glides, long
4	Glides, short (60" base only)
2	1/2 P.S. Rubber Disk Bumper
10	#6 x 1/4" type "B" philips screw

TOOLS REQUIRED

Philips screwdriver with long stem
 Flat screwdriver
 Adjustable wrench

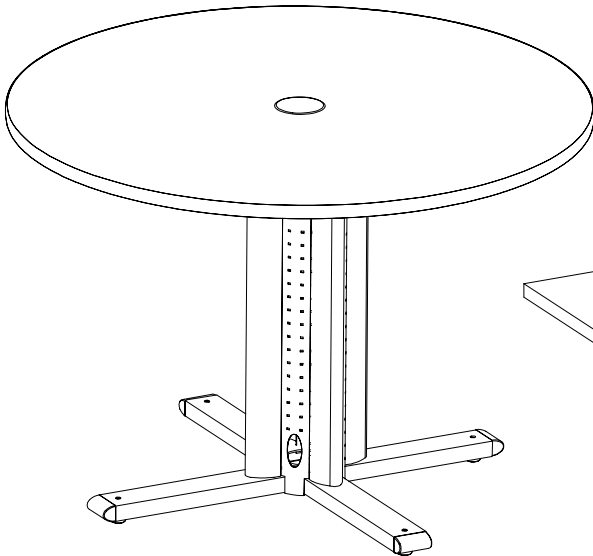

4 Power/4 Data

PPRN42STW
 PPRN48STW
 PPRN54STW
 PPRN60STW

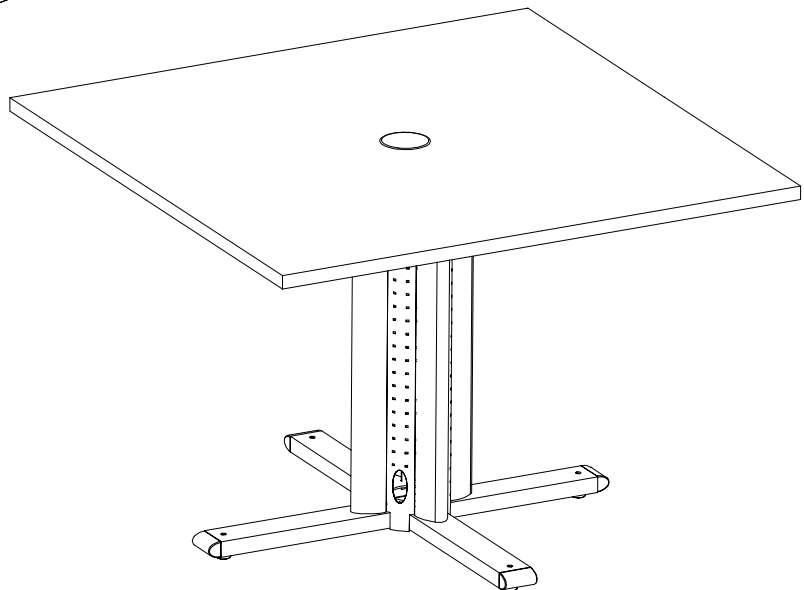

4 Power/4 Data

PPSE42STW
 PPSE48STW

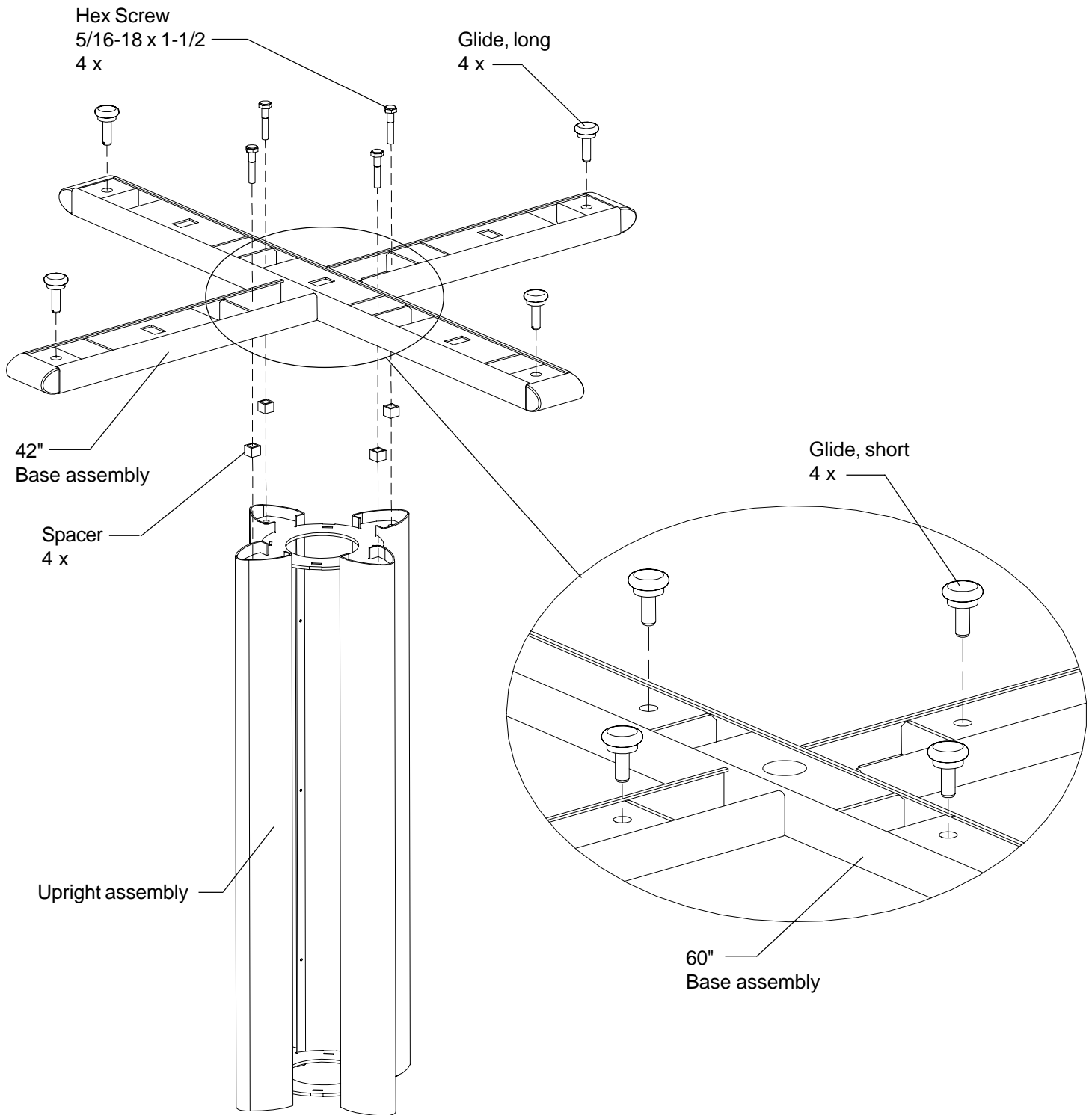

STEP 1

Attach the base assembly to the upright with the four 5/16-18 x 1-1/2" screws and the four spacers as shown. **Tighten all screws.** Screw glides all the way into the bottom of the legs.
 Once all pieces are secured, stand unit upright.

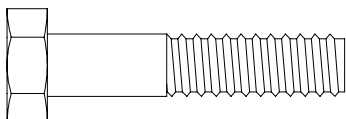

Hex Screw
5/16-18 x 1-1/2

SAFETY WARNING
Note: TWO PERSON
ASSEMBLY REQUIRED

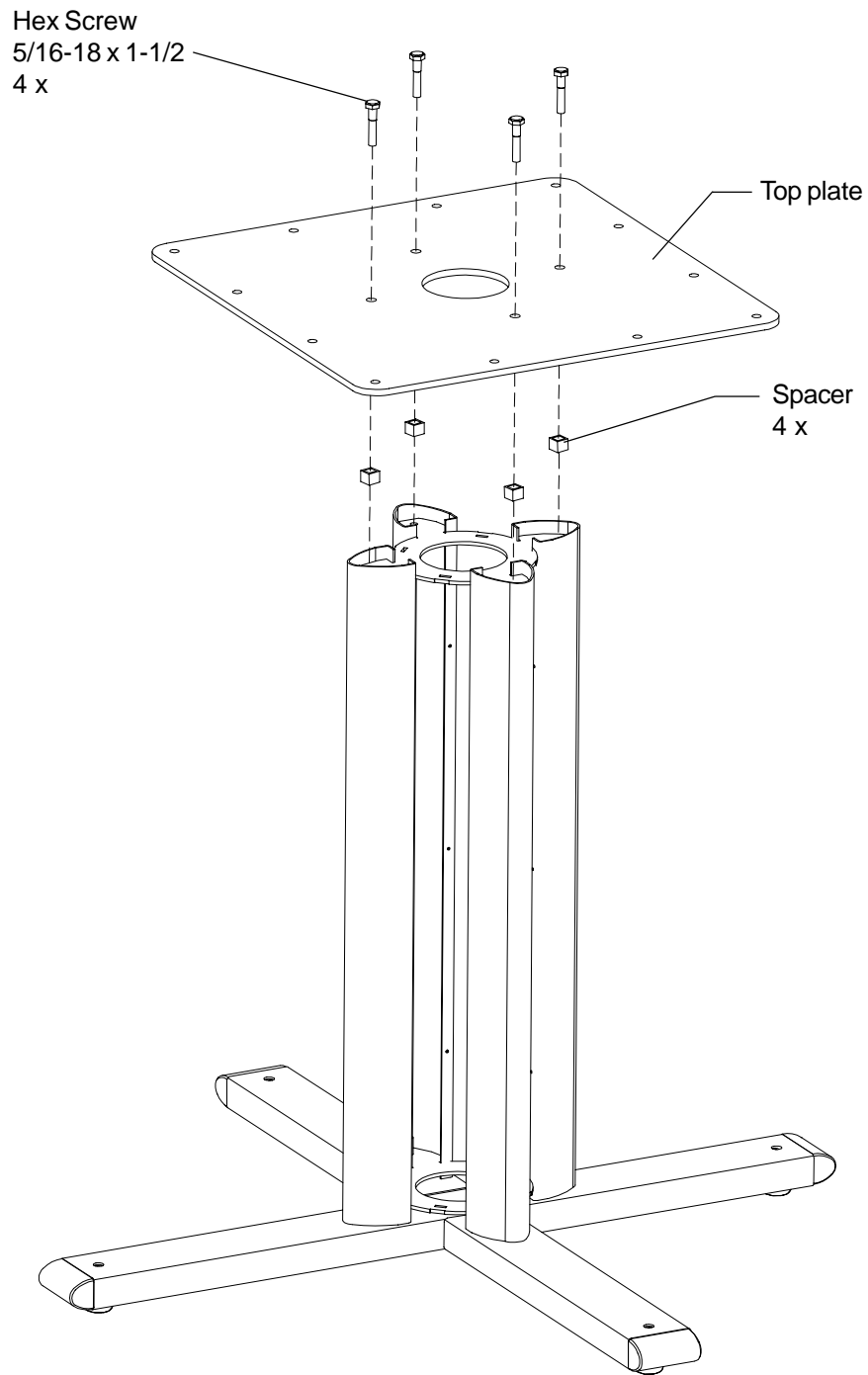

STEP 2

Attach the top plate to the upright with the four 5/16-18 x 1-1/2" screws and the four spacers as shown. **Tighten all screws.**

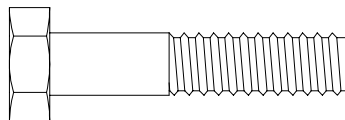

Hex Screw
5/16-18 x 1-1/2

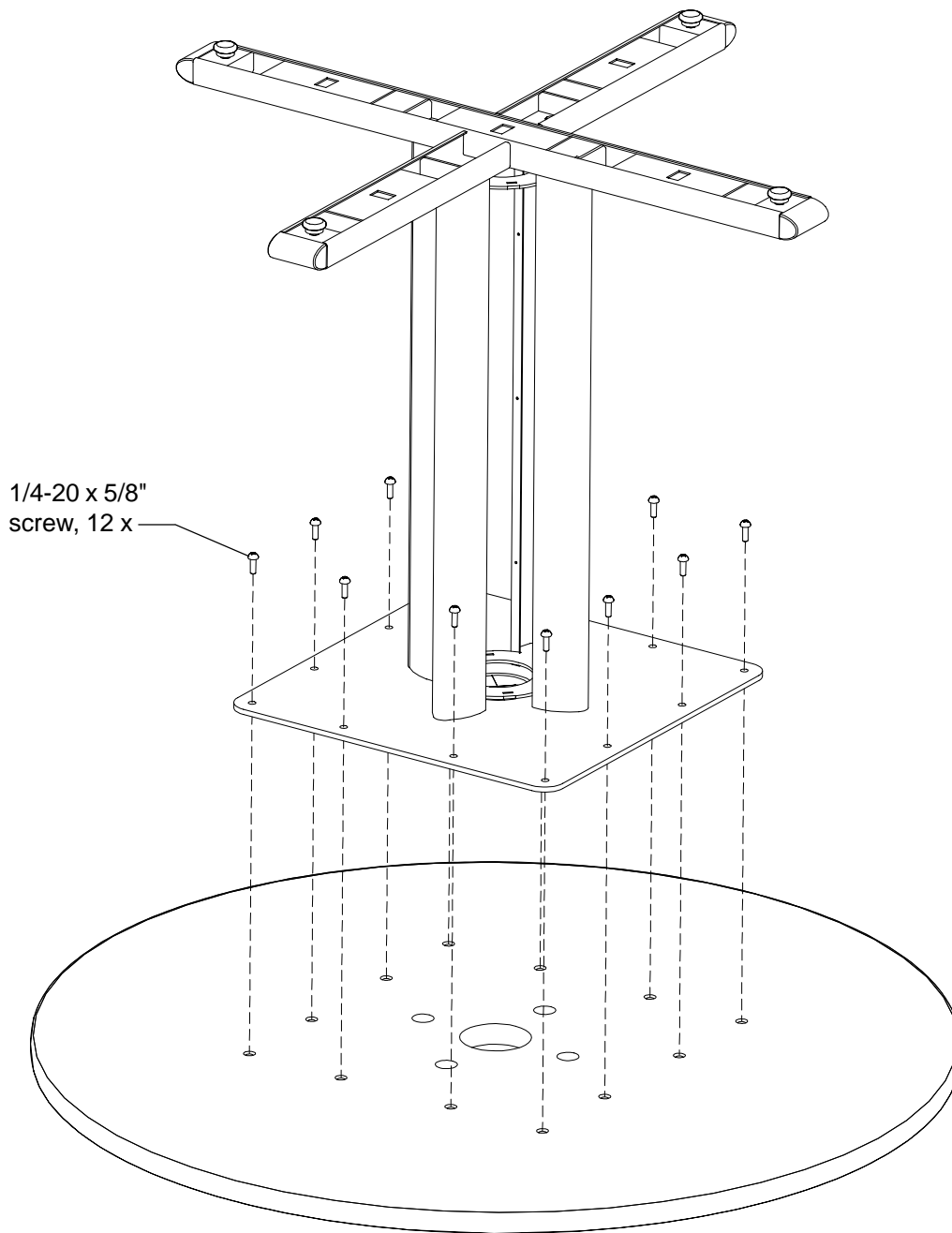

STEP 3

Lay the wood top down on a carpeted surface (or shipping carton) with holes facing up. Attach the upright assembly to the top with the twelve 1/4-20 x 5/8" screws as shown.

Once the upright is secured, stand unit upright.

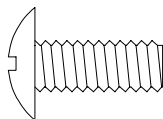

1/4-20 x 5/8" screw

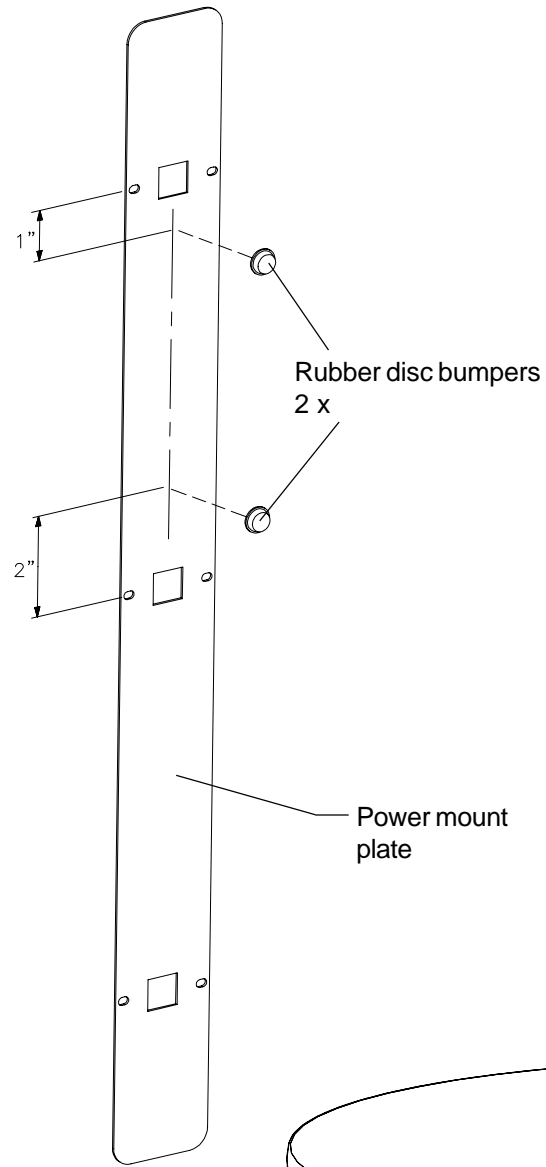

STEP 4

Before installation of the power mount plate, attach two rubber disc bumpers to its surface as shown.



Rubber disc bumper

Attach the power mount plate to the upright using six #6 x 1/4" philips screws as shown. Use philips screwdriver with long stem. Then completely tighten them.
Note: Two rubber disc bumpers must be in up position.

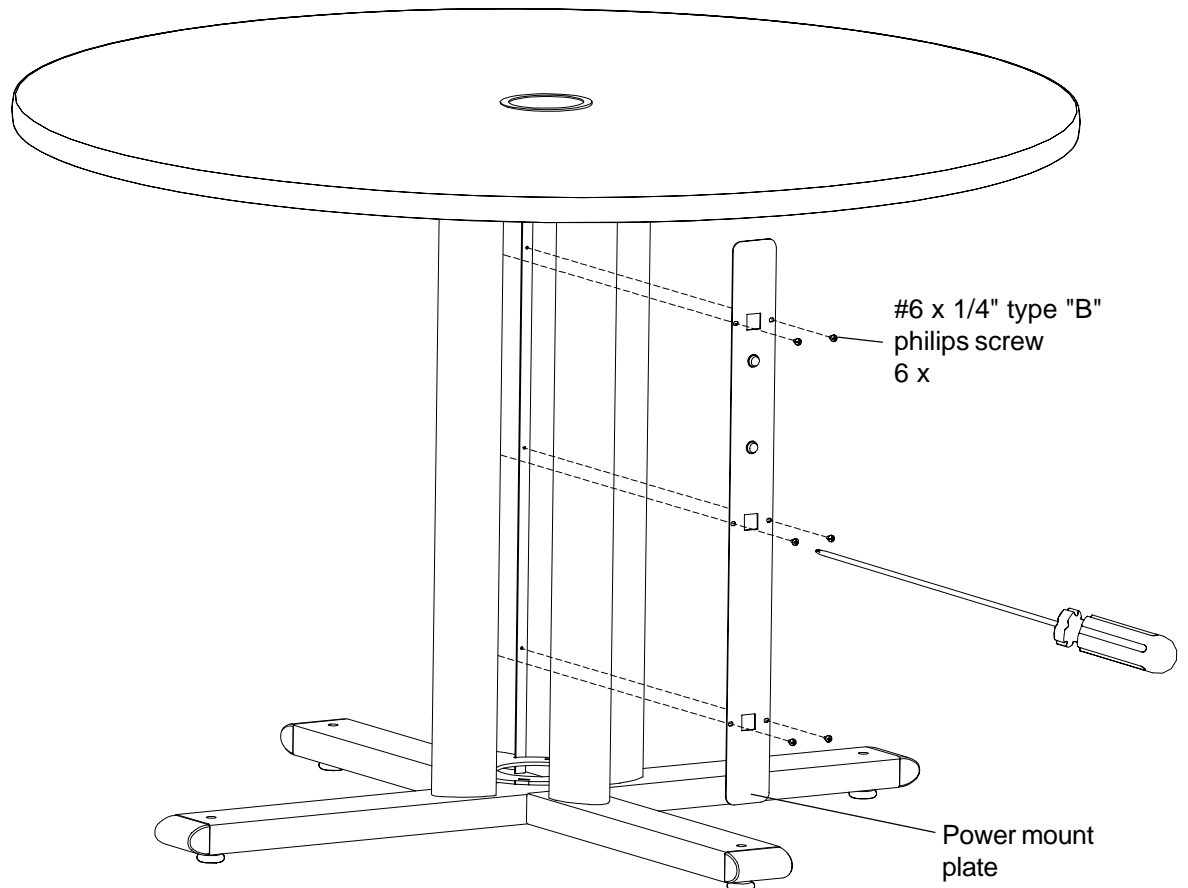

#6 x 1/4" type "B" philips screw

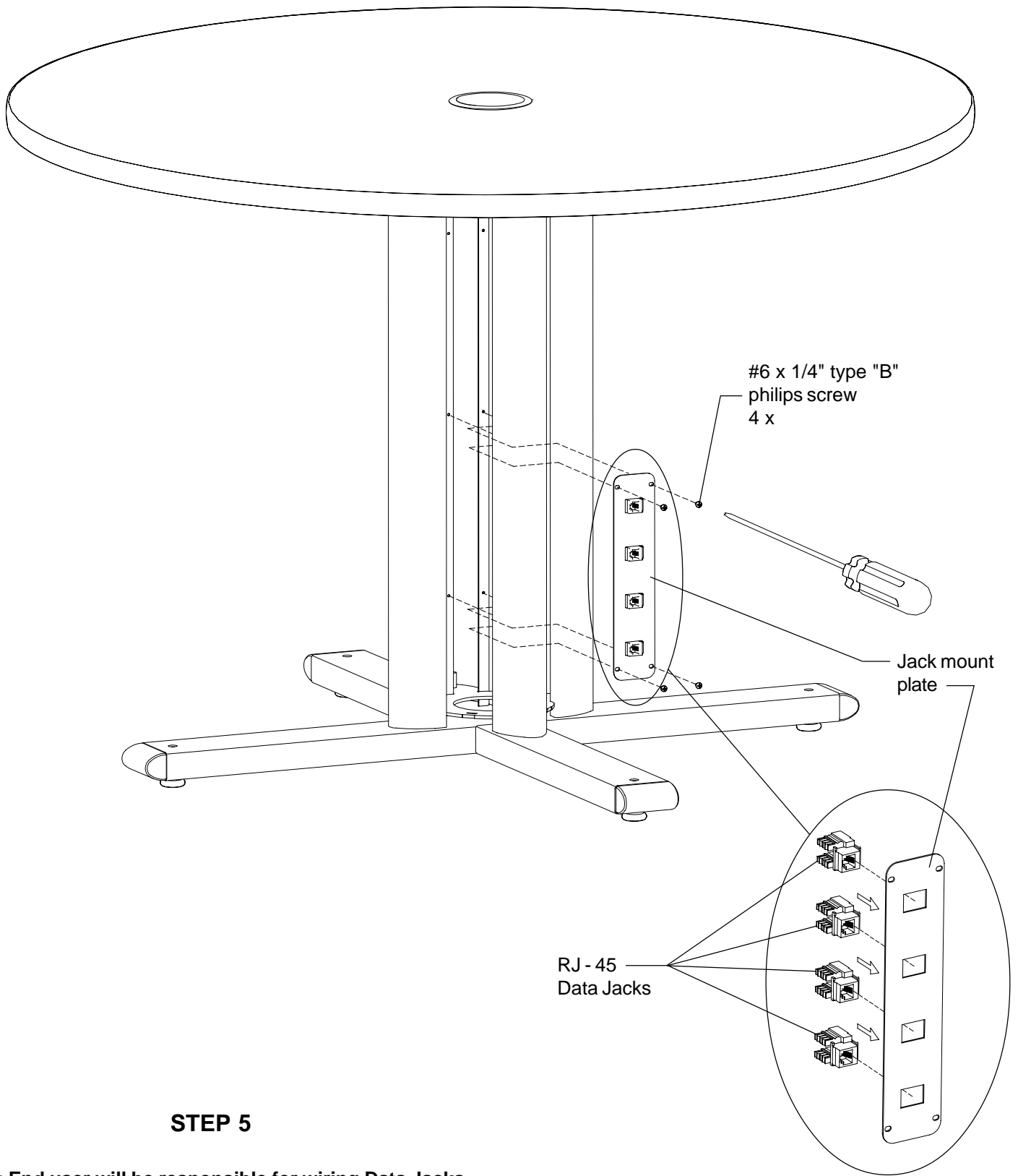

STEP 5

Note: End user will be responsible for wiring Data Jacks.

The Data Jacks and the jack mountplate will come unassembled. So, you have to snap the Data Jacks in as it shown.

After wiring is completed, take the jack mount plate and attach on the bottom of opposite side from the power mount plate inside of the upright using four #6 x 1/4" philips screws. Use philips screwdriver with long stem.

Then tighten them.



#6 x 1/4" type "B"
philips screw

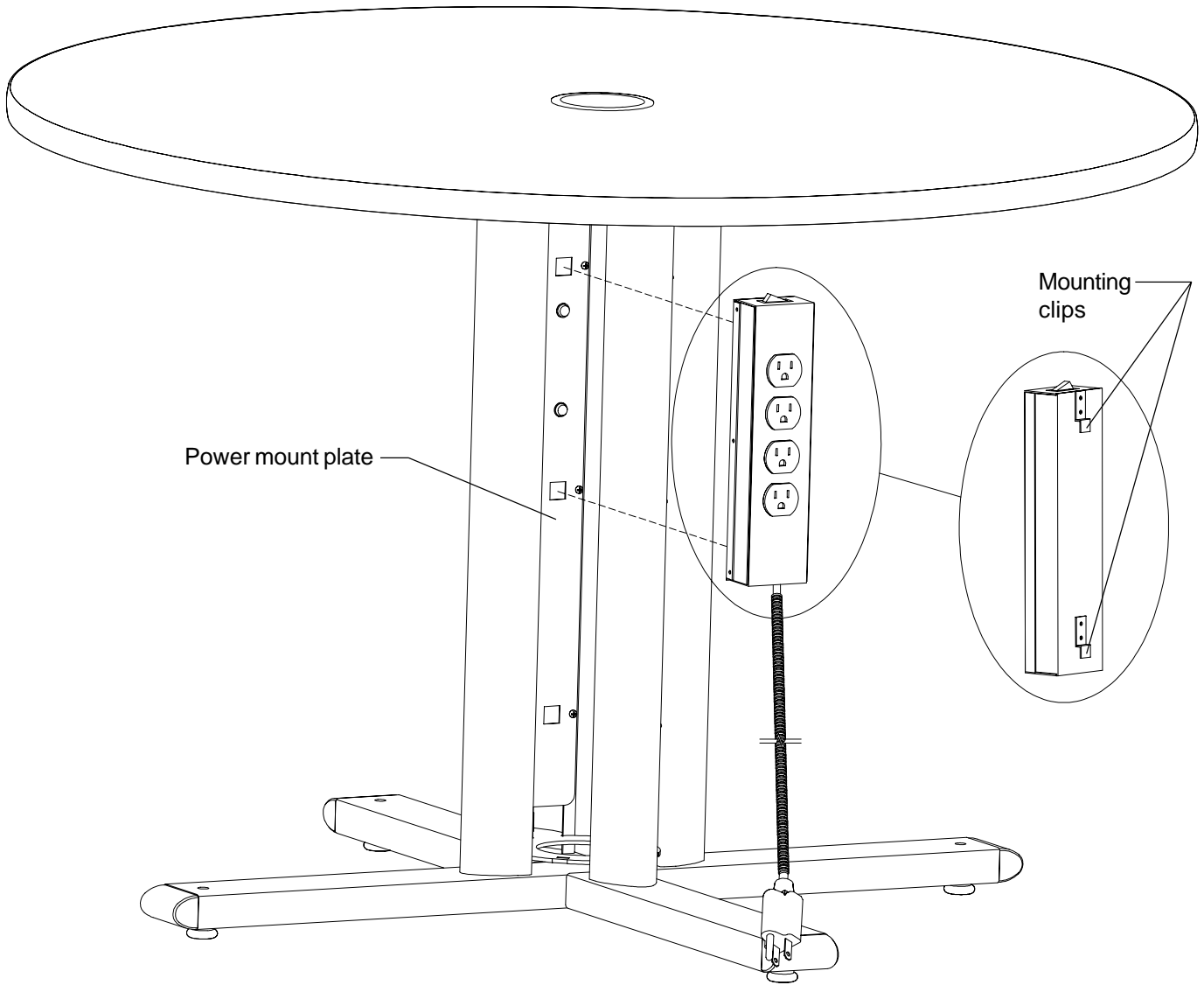

STEP 6

The electric box has two mounting clips on its back side. To hang the box insert the clips through the cutouts of the power mount plate as shown and press down until seated.

STEP 7

Install four cover panels as follows:
Use the hooks on the top and bottom of the cover panel to hang it into the top and bottom slots inside of the upright.
Before installing side cover with hole take electric cord from electric box and pull it thru the side cover's hole.

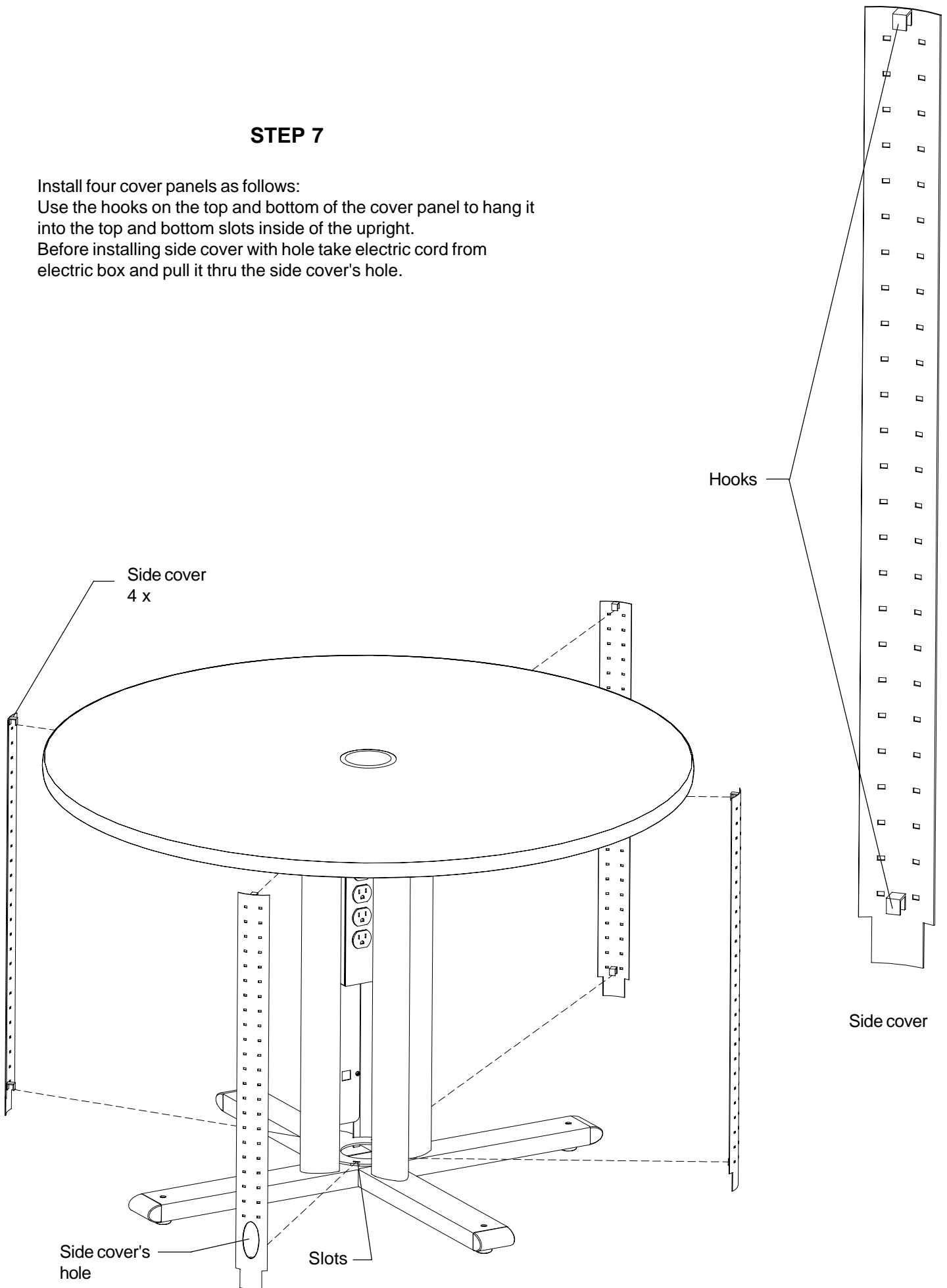

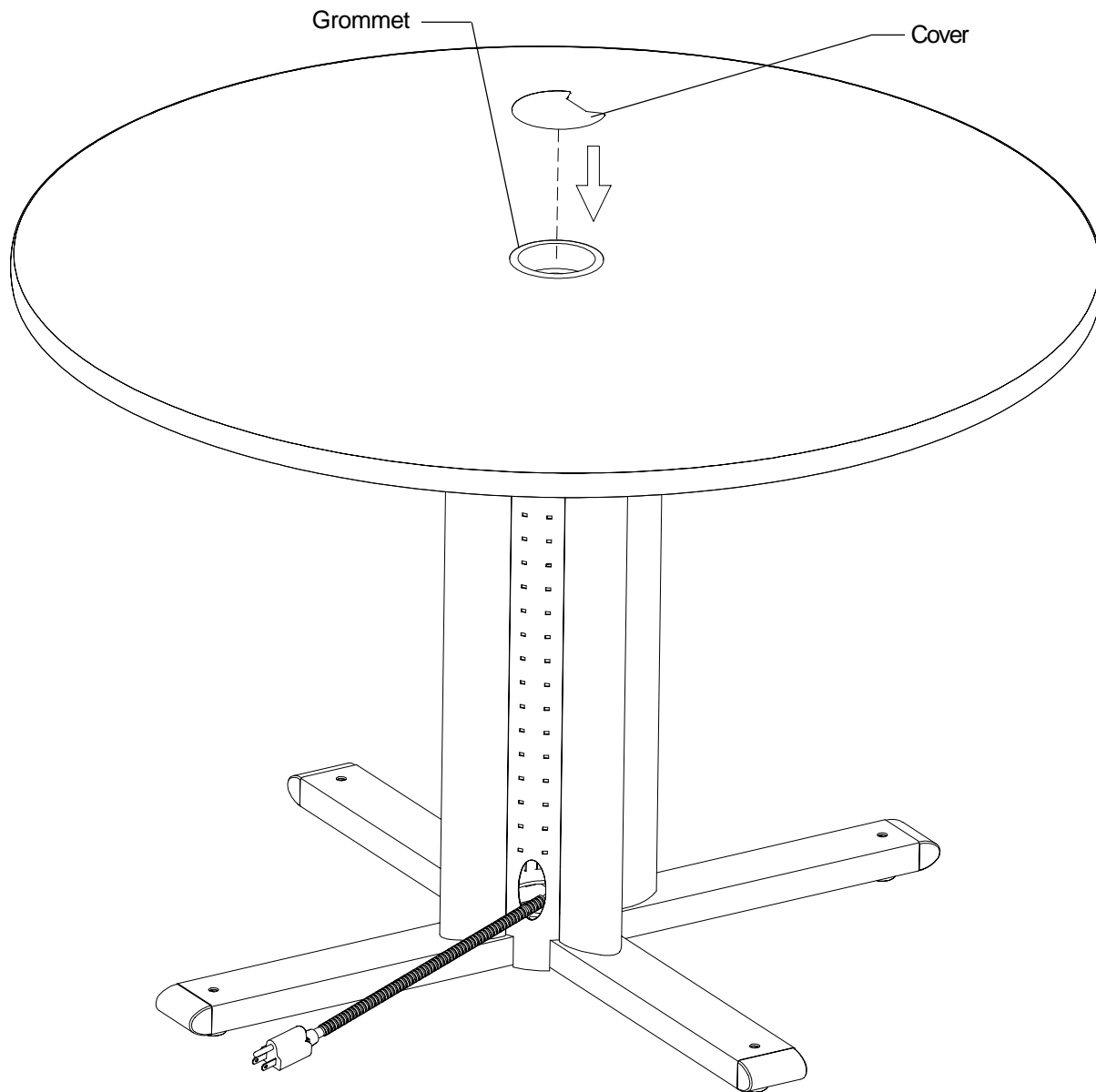

STEP 5

Upon receiving this product the grommet will be already on its place at the center of the top. Just take the cover and close the hole.

Once your table is in position, it might be necessary to level it. Determine which leg is rocking and using straight blade screwdriver, turn the glide up or down to level.

Bretford
11000 Seymour Avenue
Franklin Park, IL 60131
TEL: 847.678.2545
800.521.9614
FAX: 847.678.0852
800.343.1779

Bretford Ltd.
Technology House
7 Lake End Court, Taplow
Bucks SL6 0JQ England
TEL: 01628 603558
FAX: 01628 604923

www.bretford.com

Presentation Environments is a registered trademark of Bretford Manufacturing Inc.

Part # 031-3959
01.18.01 YP