



BRETFORD

PRESENTATION ENVIRONMENTS®

TransTable®

Each Table Contains:

- 1 Wood Top
- 1 Leg Base Assembly
- 4 1/4-20 x 5/8" Screws

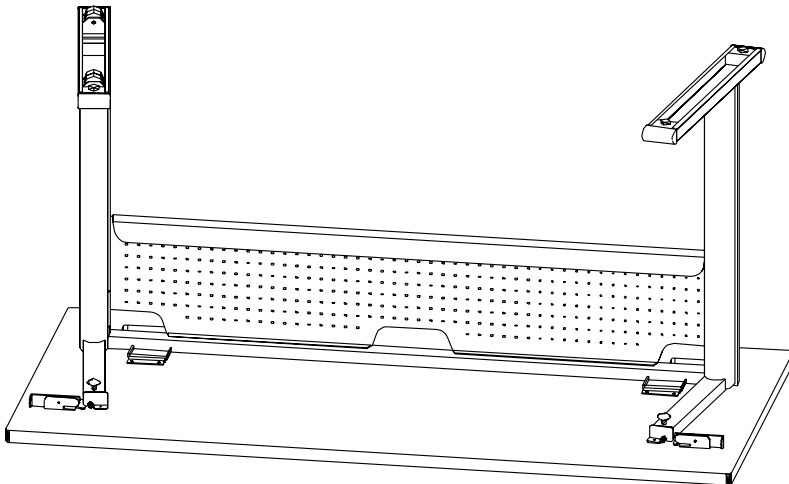
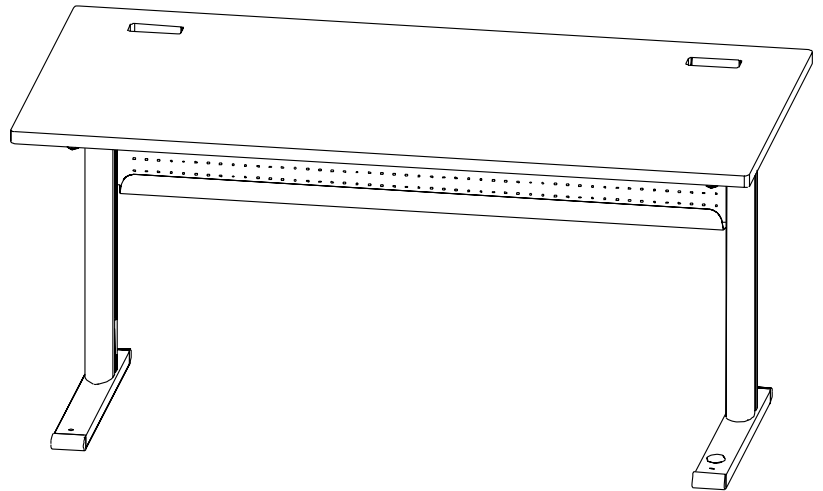

FIGURE 1

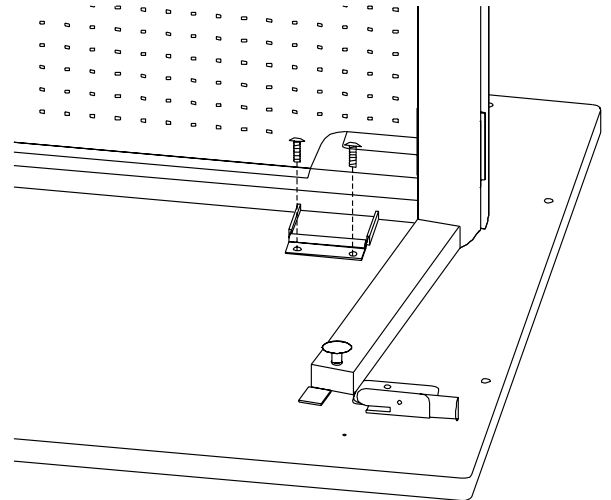
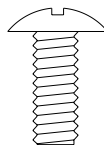

FIGURE 2

STEP 1

Lay wood top on a clean flat surface with holes facing up. Position leg base onto wood top with legs turned in slightly (**Figure 1**). **LOOSELY** attach together through hinges using 1/4-20 x 5/8" screws as shown (**Figure 2**). Swing legs into place. When you hear the knob snap into place, the legs are locked in place. If the legs do not snap into place, you may need to loosen the screws on the plates in the wood top to adjust legs. Once legs are adjusted properly, **TIGHTEN THE HINGE SCREWS**.



LOCKING AND UNLOCKING WHEELS

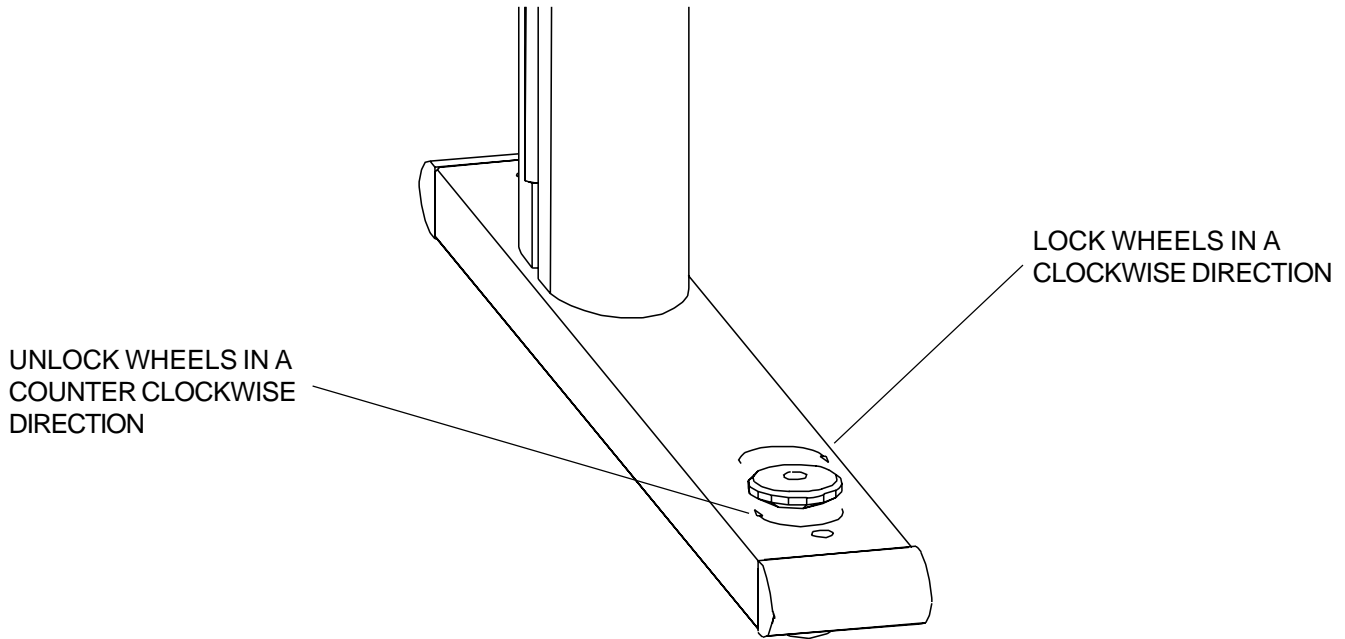

NOTE: The rout on the underside of the table opposite the wheels is for ease of lifting and moving of the table. When the table is open, make sure the wheels are in the locked position. When rolling or folding table, remove all items for the table top.

CLOSING TABLE

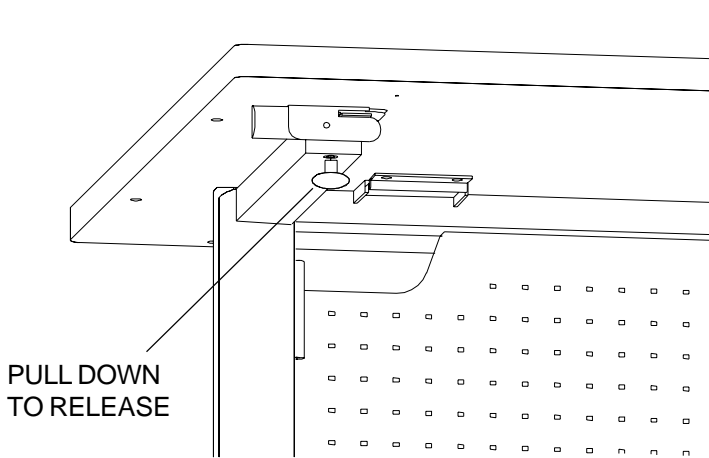

FIGURE 3

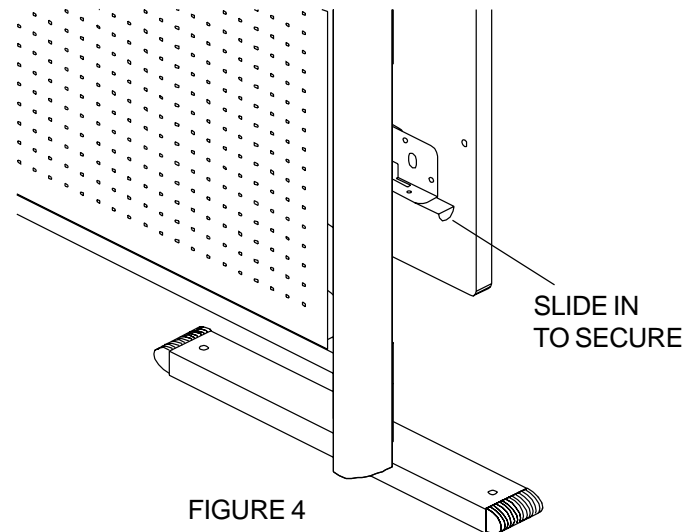
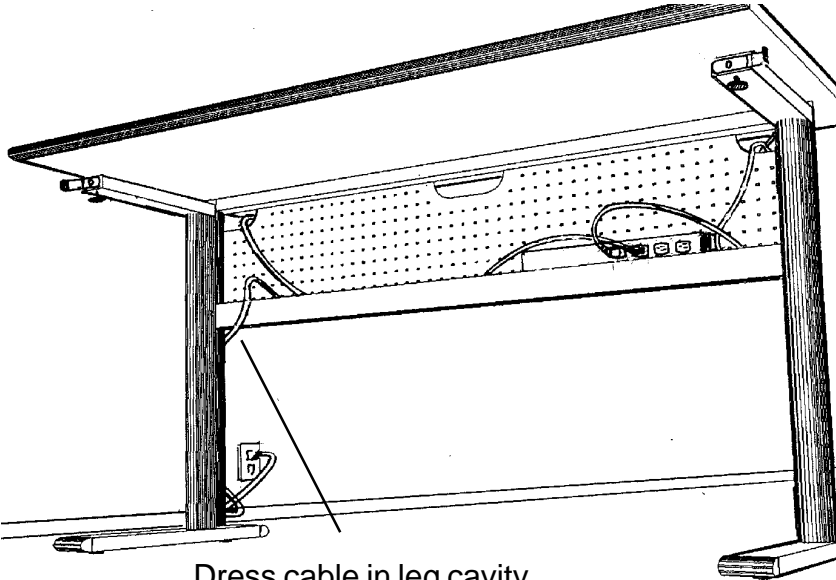
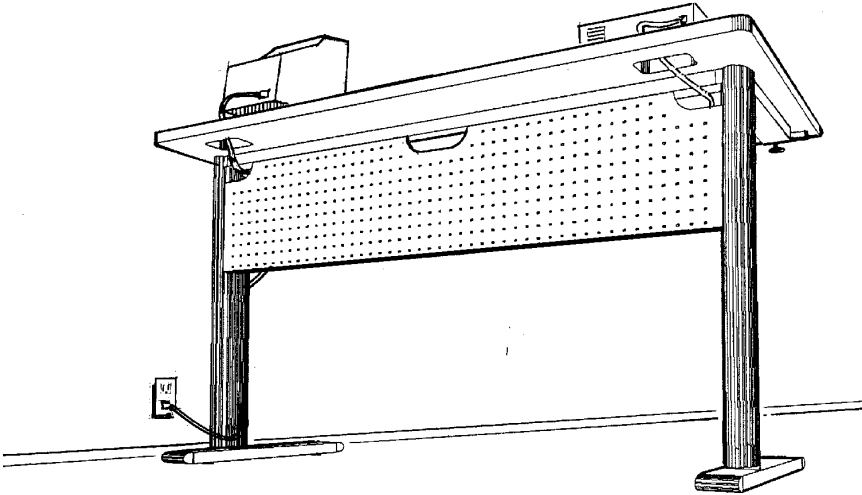

FIGURE 4

Close one leg at a time. Pull knob down to release leg and slide leg into base. When closing second leg, guide table top slowly down as leg is sliding in. (**Figure 3**) Once legs and top are in place, secure them together by closing latches on both sides as shown. (**Figure 4**) This will prevent the unit from opening.

SUGGESTED CABLE MANAGEMENT



Dress cable in leg cavity.

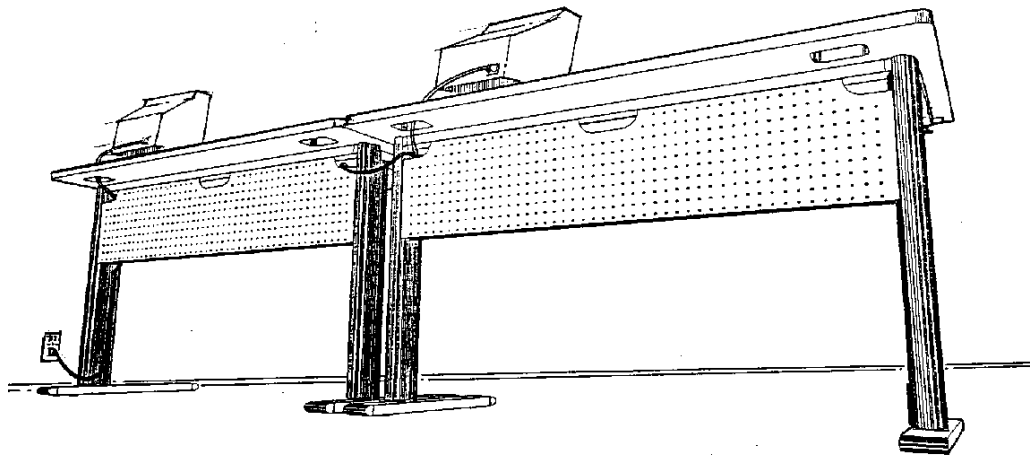

Dress table to table connections as shown.

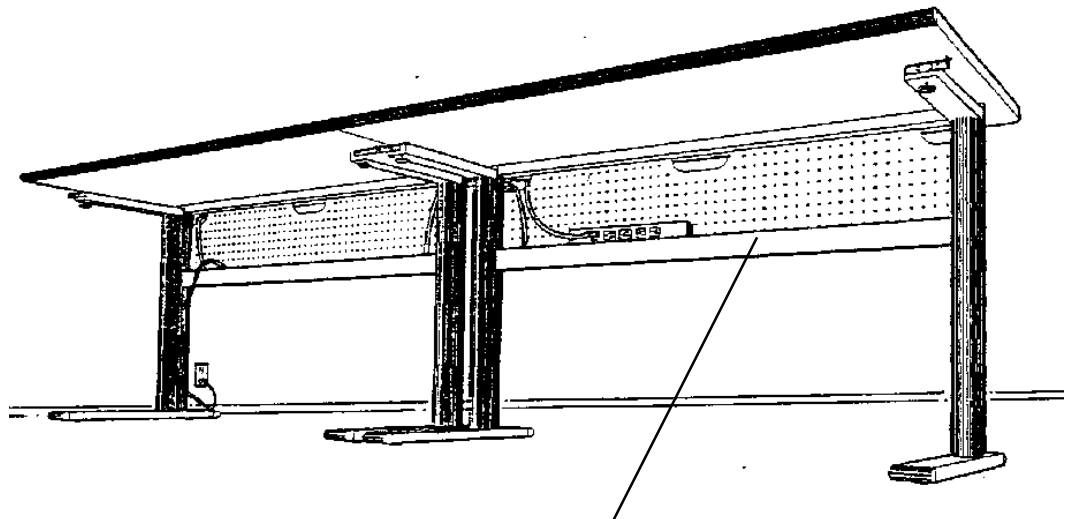

Raceway can accommodate most notebook power packs.

Bretford
11000 Seymour Avenue
Franklin Park, IL 60131
TEL: 847.678.2545
800.521.9614
FAX: 847.678.0852
800.343.1779

Bretford Ltd.
Technology House
7 Lake End Court, Taplow
Bucks SL6 0JQ England
TEL: 01628 603558
FAX: 01628 604923

www.bretford.com

Part #031-2513
Rev. 10.21.03CH