

Assembly Instructions

BRETFORD LEGACY COLLECTION

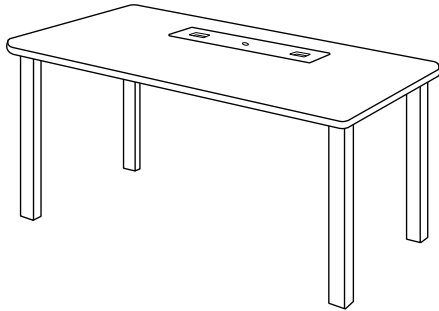

TECHNOLOGY TABLES



BRETFORD

PARTS LIST

REF	QTY	PT NO	DESCRIPTION
	1		Table Top
	2		Rear Hardwood Leg
	2		Front Hardwood Leg
	4	010-2371	Square Leg Plate
	1	010-2492	Long Mounting Bracket (for 39" Units only)
	2	010-2494	Short Mounting Bracket (for 39" Units only)
	2		Front Leg Stiffener (for 39" Units only)
	1		Rear Leg Stiffener (for 39" Units only)
	1		Wire Management Bin
	1		Wire Access Door (2 on 72" and 96" Tables)

HARDWARE LIST

REF	QTY	PT NO	DESCRIPTION
AA	4	HD1128	Leveler
BB	8	SC1060	5/16 x 3" Machine Bolt
CC	20	SC1061	5/16 x 1 1/4" Machine Bolt (8 attached to top)
DD	22	SC1051	Machine Screw (for 39" Units, only)
EE	14	030-0383	Wood Screw
FF	4	HD1129	Steel Dowel
GG	4	030-0433	#10-32 Knurled Brass Screw
HH	4	030-0465	Nylon Washer
II	8	02132	#4 x 1/4" Type 'B' Screw
JJ	1	HD1250	Lock Assembly w/hardware (2 on 72" and 96" Tables)
KK	1	010-3012	Cam - Lock (2 on 72" and 96" Tables)

STEP 1

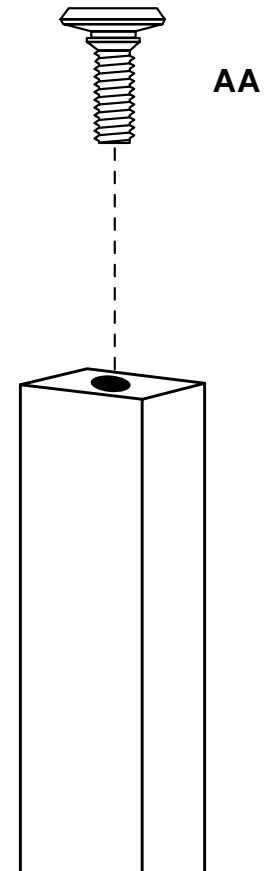

Fully install levelers (AA) on the bottom of each Leg.

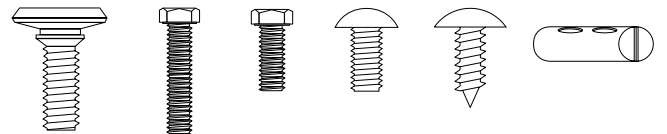

AA

BB

CC

DD

EE

FF

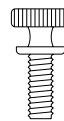

GG

HH

II

JJ

STEP 2

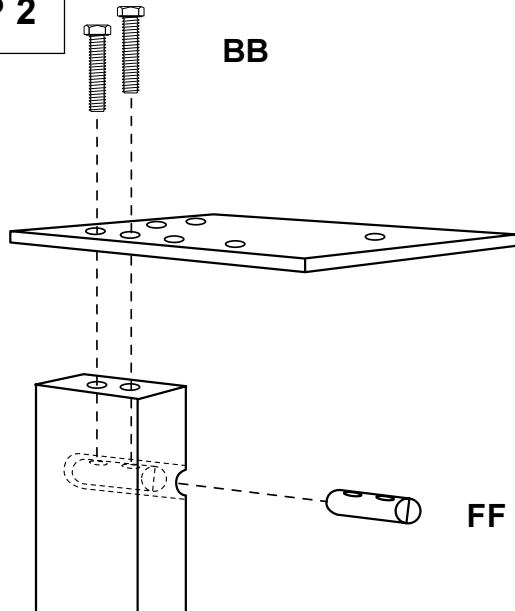

Insert Steel Dowel (FF) into leg as shown. Rotate Dowel so that the slot in the end is vertical, as shown. Attach Steel Plate* to top of leg with two 3" Bolts (BB), inserting through plate and into holes in Steel Dowel. Be sure to orientate the Leg so that the edges away from the Dowel hole are flush with the edges of the Plate, as shown. Repeat for each leg. *Plates are attached to wood top. Remove, save bolts and follow above directions.

STEP 3

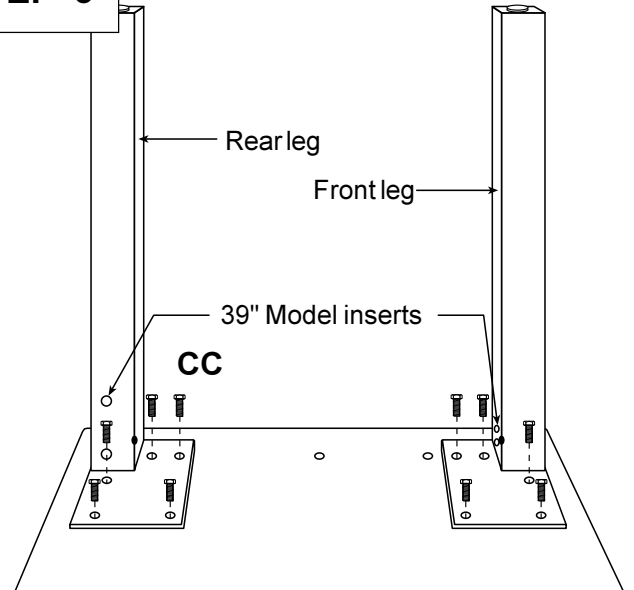

Attach each Leg assembly to table top using five (5) Bolts (CC) as shown. Note: for 39" Models, finger tighten bolts only.

Special Orientation of Legs on 39" Models: Notice the inserts in the sides of the legs located near the Plate. The rear legs have inserts spaced 6" apart, and should be located along the table edge nearest the Wire Access Door cut-out with the inserts facing inward/towards each other. The front legs have inserts spaced 3" apart, and should be located along the table edge away from the Wire Access Door cut-out, and with the inserts facing the rear legs.

STEP 4

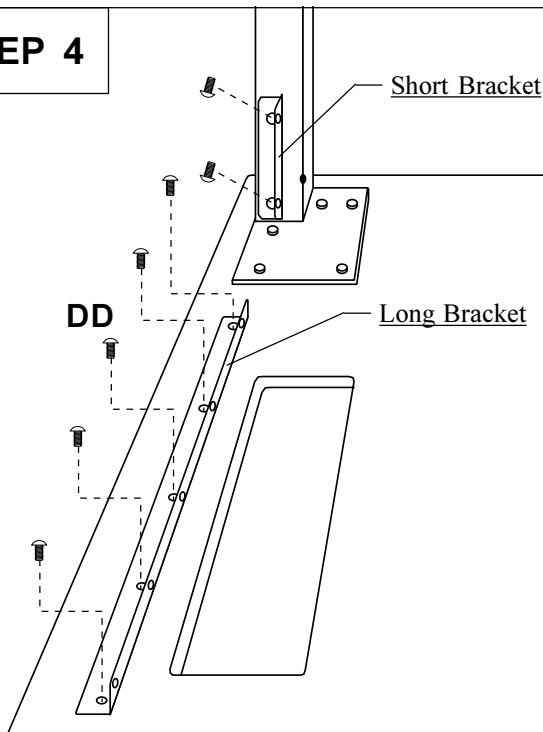

Note: Steps 4 thru 6 are for 39" Models Only.

Install long "L"-Shaped Bracket with flange facing front as shown. Align holes with pre-drilled holes in tabletop. Attach with SC1051 screws (DD).

Install short "L"-Shaped Bracket on rear leg with flange facing front as shown. Repeat for other rear leg.

STEP 5

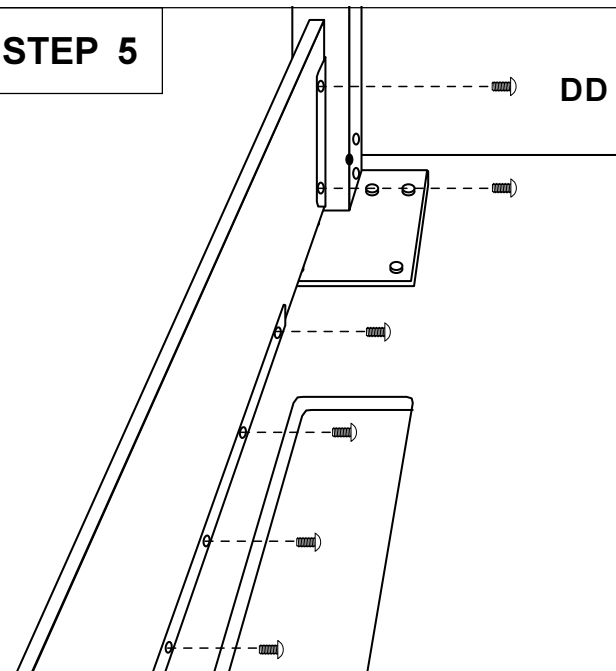

NOTE: Step 4 thru 6 are for 39" Models Only.

Position Rear Leg Stiffener as shown. Align holes in stiffener with predrilled holes in Brackets. Attach with screws (DD). Then completely tighten rear leg plate bolts.

STEP 6

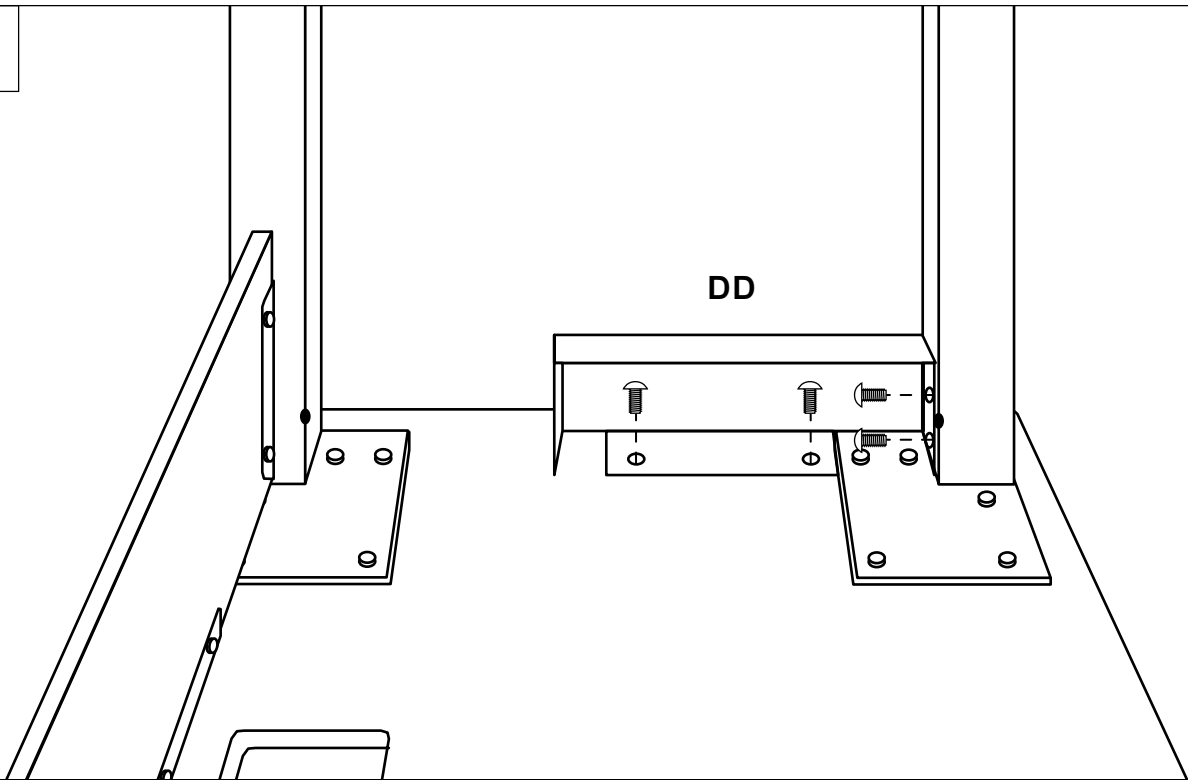

Note: Steps 4 thru 6 are for 39" Models Only.

Position Front Leg Stiffener as shown. Align holes in stiffener with predrilled holes in tabletop. Attach with screws (DD). Then completely tighten front leg plate bolts.

Repeat for other Front Leg.

STEP 7

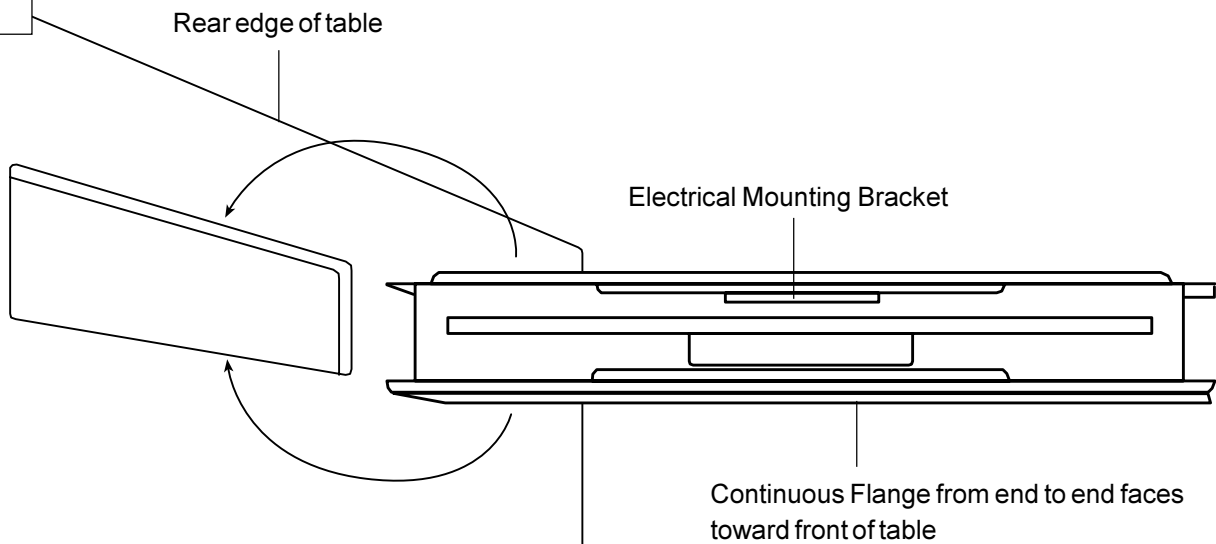

Orientate Wire Management Bin as Shown.

STEP 8

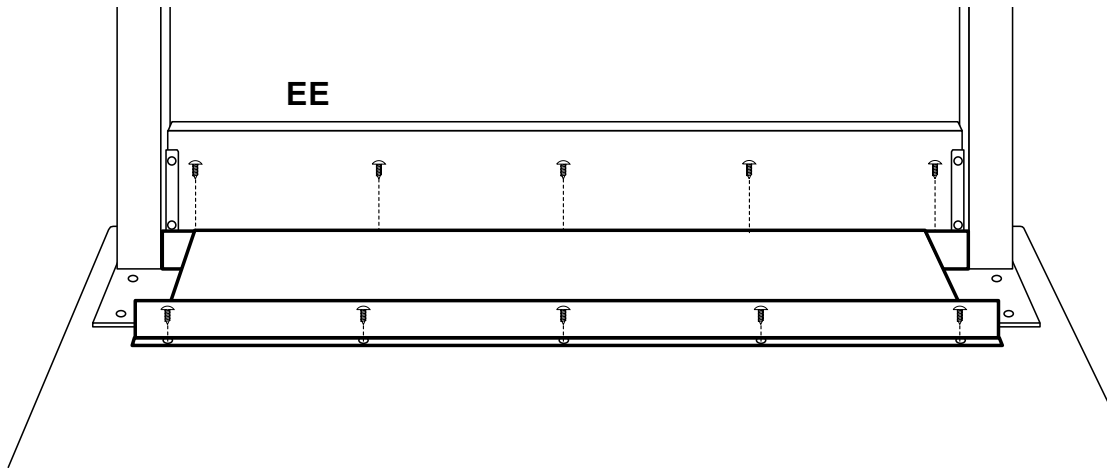

NOTE: If End Caps have been purchased, they should be assembled to Wire Management Bin prior to attaching Bin to tabletop. For correct position, see End Cap instruction sheet.

Position Wire Management Bin as shown. Align holes in Bin with predrilled holes in tabletop. Attach with self-tapping screws (EE). A magnetic screwdriver would be helpful for attaching rear screws.

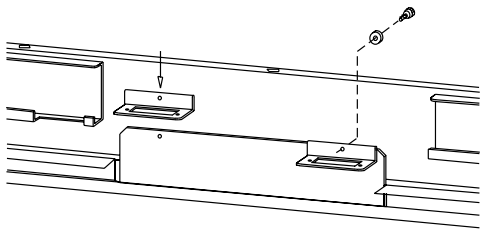

Detail A

Showing Wire Bin detail for installation of Data Clip. Slide data clip onto wire bin flange, lining up the mounting holes. Install nylon washer and thumb screw as shown. (Front flange of the wire bin has been removed for clarity.)

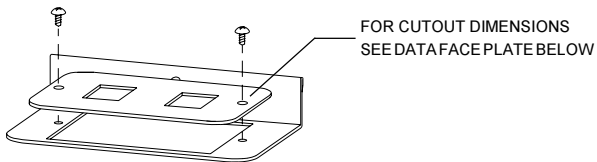

Install appropriate data clip cover to the data clip using #4 X 1/4" self tapping screws.

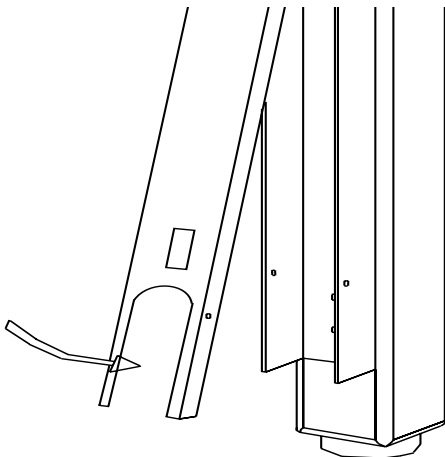

STEP 9

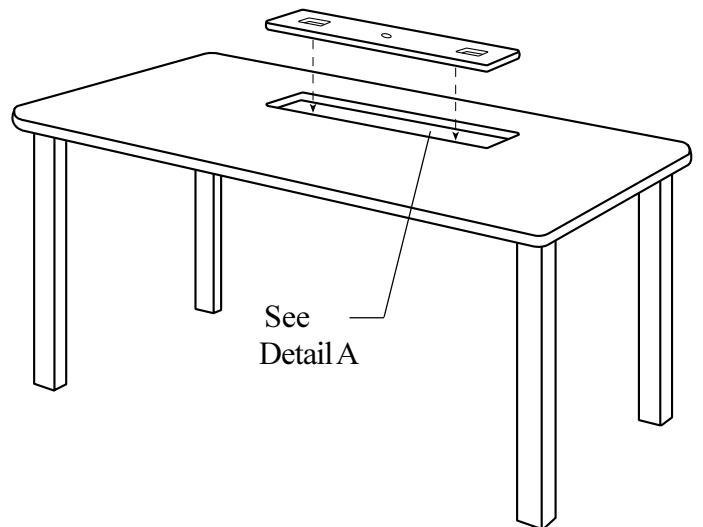

Seek assistance in turning table to standing position. Insert Wire Access Door in tabletop as shown.

For installing software or hardware applications, see their instruction sheets.

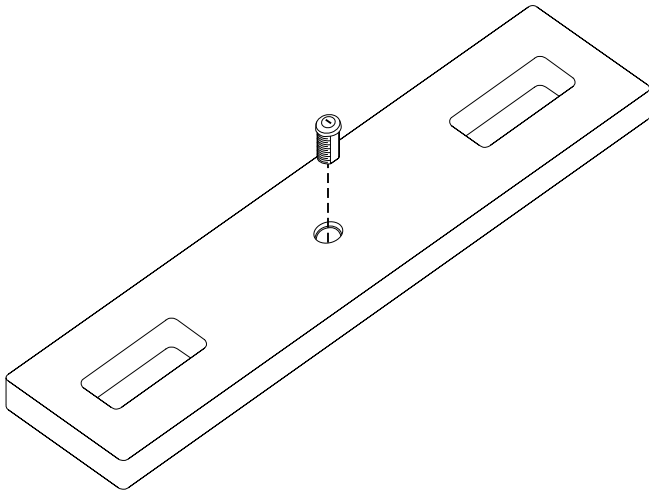

STEP 10

Install cylinder lock (JJ) with the flats of the cylinder parallel with the front/rear edges, through the counterbore hole.

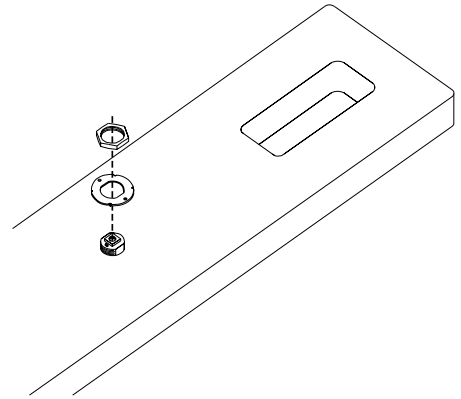

STEP 11

Flip the door panel over and place the cylinder washer (with points facing down) over lock cylinder. Secure lock nut onto cylinder lock and tighten.

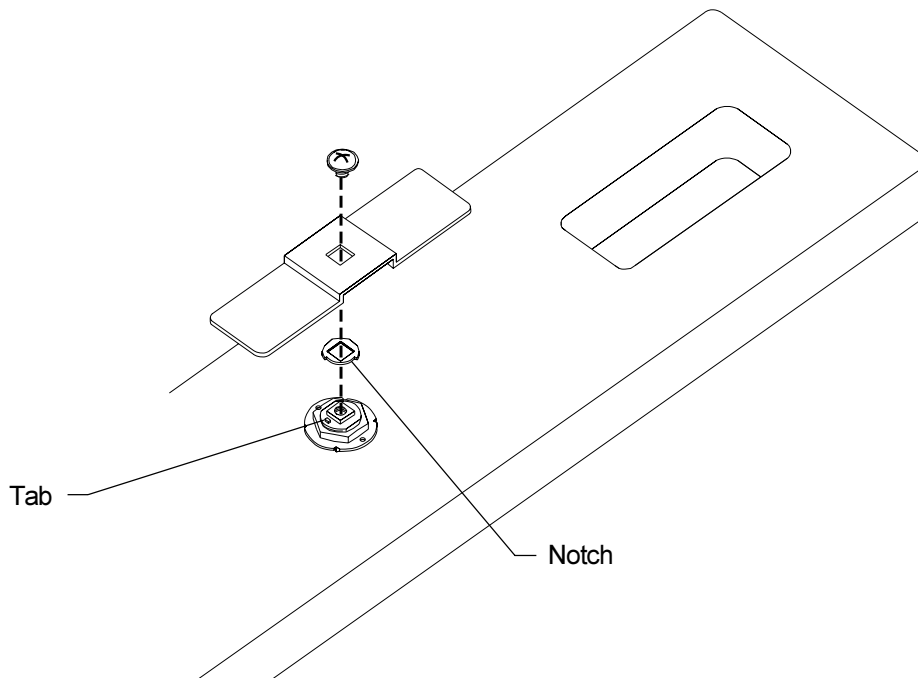

STEP 12

Place the washer (with 90 degree stop notch) onto the cylinder lock square post as shown. Attach the locking cam (KK) onto the lock square post. Insert the screw into threaded end of square post and tighten.

Place completed door(s) into cutout of table.

Bretford
 11000 Seymour Avenue
 Franklin Park, IL 60131
 TEL: 847.678.2545
 800.521.9614
 FAX: 847.678.0852
 800.343.1779

Bretford Ltd.
 2 Etongate
 110 Windsor Road
 Slough, Berkshire SL1 2JA England
 TEL: 01753 216531
 FAX: 01753 539478