

# WV336

## WOOD MOBILE UTILITY TRUCK

### Assembly Instructions

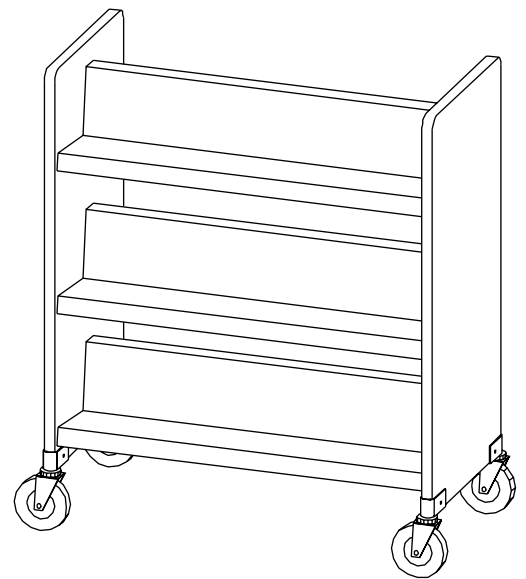

#### PARTS LIST

Qty	Part#	Description
2	SA1559	Wood Side Panels
3	010-2089	Steel Shelves
2	015-0002	4" Casters w/o Lock
2	015-0003	4" Casters w/ Lock
<b>OR</b>		
2	015-0017	5" Casters w/o Lock
2	015-0018	5" Casters w/ Lock

#### HARDWARE LIST

Qty	Part#	Description
30	030-0304	1/4-20 x 5/8" Combo Truss Screws

#### TOOL REQUIRED

Phillips Screwdriver  
Rubber Mallet

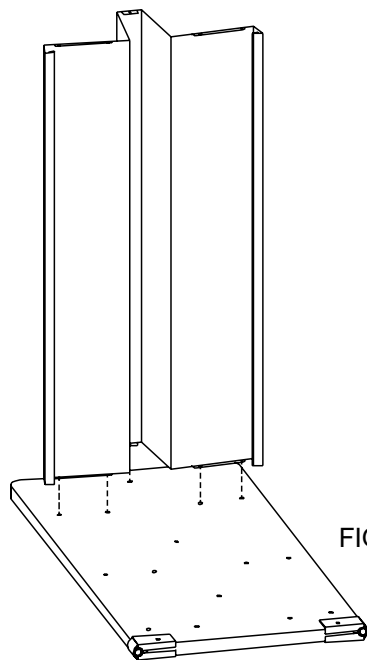

FIGURE 1

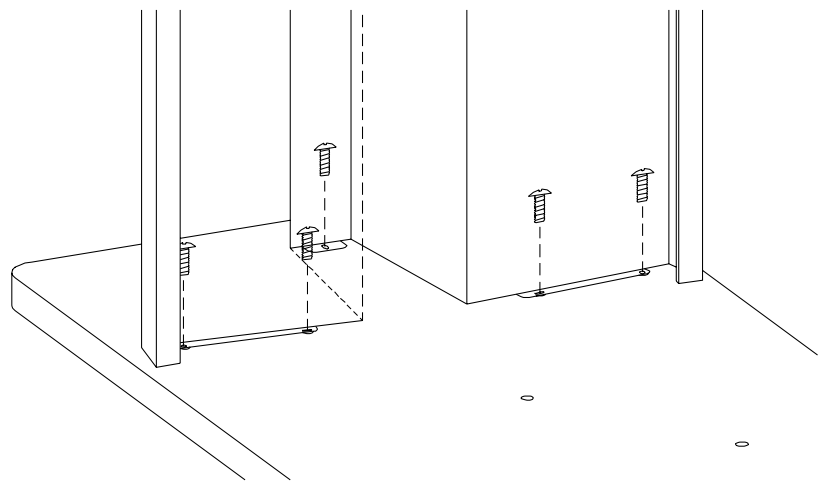
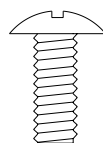
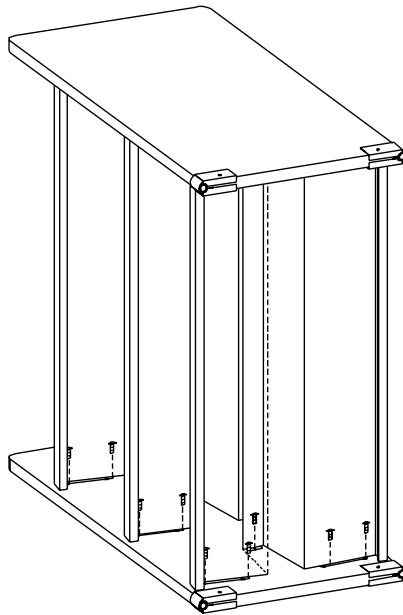

FIGURE 2

#### STEP 1

Lay one side panel on a carpeted surface with holes facing up. Position the top shelf (it has a label) onto the side panel so that all 5 holes are aligned (**FIGURE 1**). Starting with the single center hole, secure the shelf in place using the 1/4-20 screws provided as shown in **FIGURE 2**. Attach the 2 remaining shelves in the same manner.





## STEP 2

Lay the other side panel down with holes facing up. **CAREFULLY** lift and turn the shelf assembly over and position it onto the side panel so that all holes are aligned. Secure all shelves in place as described in STEP 1.

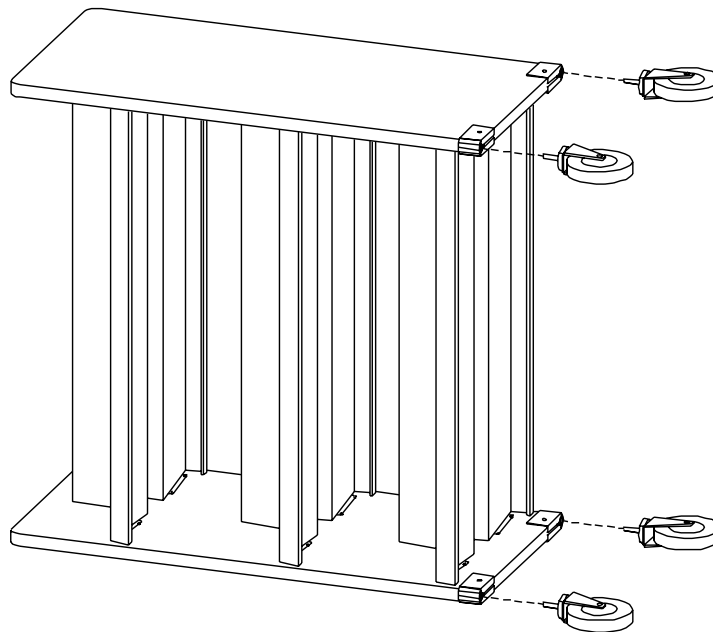

## STEP 3

Insert each caster into the sockets in each side panel. If casters do not insert easily, use a rubber mallet to tap each caster in place. **NOTE:** Make sure each caster is **SECURELY** seated in each socket before standing unit upright.

**Bretford**  
11000 Seymour Avenue  
Franklin Park, IL 60131  
TEL: 847.678.2545  
800.521.9614  
FAX: 847.678.0852  
800.343.1779

**Bretford Ltd.**  
Technology House  
7 Lake End Court, Taplow  
Bucks SL6 0JQ England  
TEL: 01628 603558  
FAX: 01628 604923

[www.bretford.com](http://www.bretford.com)

Part #031-1441  
10.02.96 CH