



BRETFORD

PRESENTATION ENVIRONMENTS®

PRESENTATION CABINET

Assembly Instructions

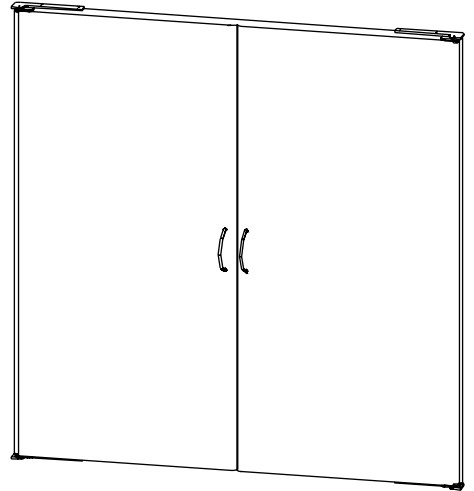

CAUTION: Hardware for fastening cabinet to wall is **NOT INCLUDED**. Installer **MUST** determine wall construction and **OBTAIN PROPER HARDWARE** for installation. Bretford Manufacturing, Inc. will not be liable for the improper use or installation of its products.

PARTS LIST

Qty	Description
1	Presentation Cabinet Assembly
2	Handles with Screws
1	Mounting Bracket

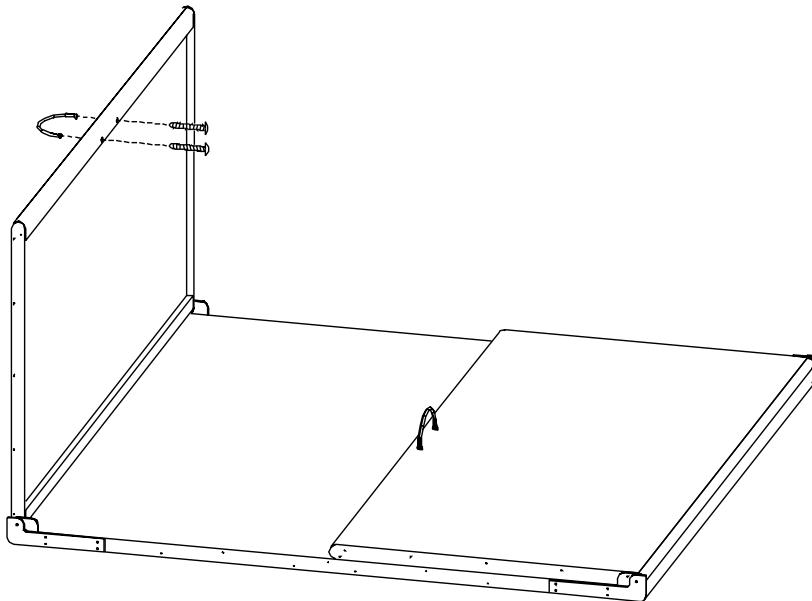

STEP 1

With someone's assistance and by holding the wood portion of the cabinet, **CAREFULLY** lift the cabinet out of the box and place it onto a carpeted surface. Attach a handle to each door as shown using the hardware provided.

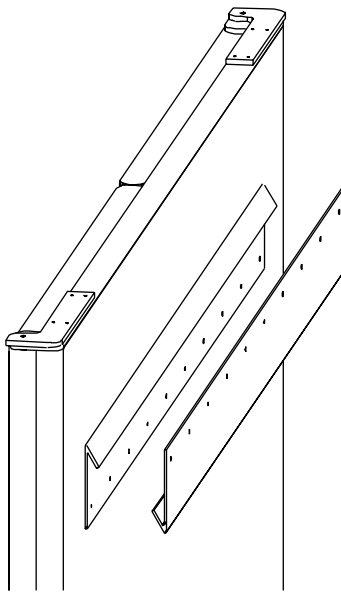

FIGURE 1

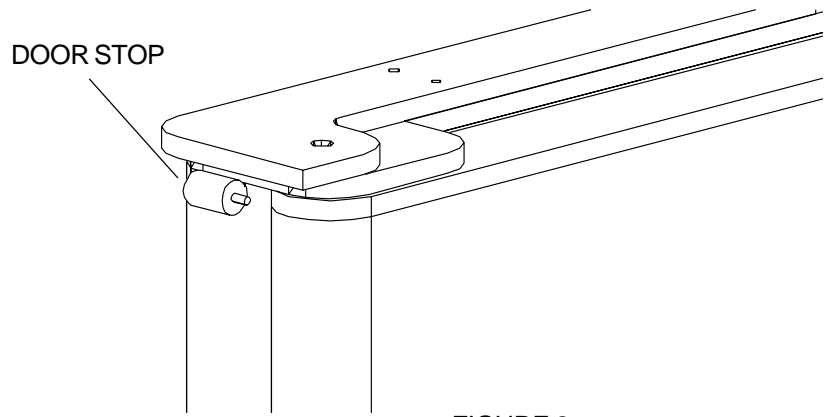
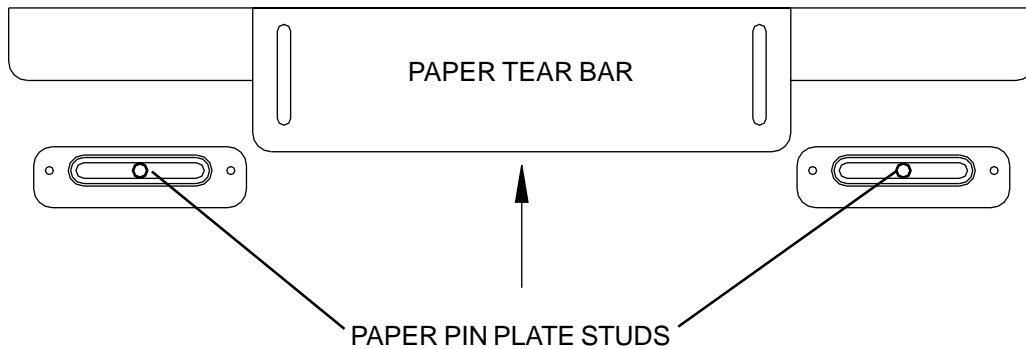

FIGURE 2

STEP 2

After attaching the mounting bracket to the proper surface with **hardware supplied by the installer**, hook the cabinet assembly onto the bracket in the manner shown in **Figure 1**. **Figure 2** shows the factory installed door stops on the side of the doors. Should any adjustment be necessary, the set screw may be adjusted by using a 1/8" hexagon Allen wrench.



STEP 3

To attach your easel paper, slide the paper tear bar up and hook your pad of paper onto the studs in the paper pin plates. The studs slide back and forth to adjust paper position. **NOTE:** An easel pad size of 20" x 34" fits the best on these plates. There is a tack board surface located on the upper section of the right door. Push pins can be used on this surface for any notes or papers.

Bretford
 11000 Seymour Avenue
 Franklin Park, IL 60131
 TEL: 847.678.2545
 800.521.9614
 FAX: 847.678.0852
 800.343.1779

Bretford Ltd.
 Technology House
 7 Lake End Court, Taplow
 Bucks SL6 0JQ England
 TEL: 01628 603558
 FAX: 01628 604923

www.bretford.com

Presentation Environments® is a registered trademark of Bretford Manufacturing, Inc.

Part #031-2574
 Rev. 07.08.98 CH