



BRETFORD

UCS925

MULTIMEDIA TABLE

Assembly Instructions

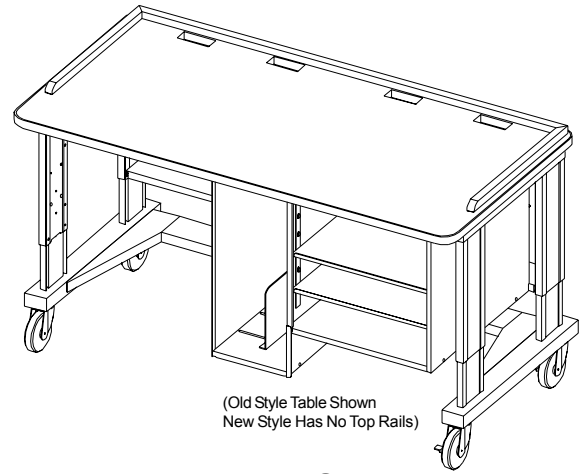

(Old Style Table Shown
New Style Has No Top Rails)

PARTS LIST

Qty	Part #	Description
1	SA7761 (New)	Wood Top No Rails & 4 Plastic Grommet Part #012-0616
	SA2343 (Old)	Wood Top w/Rails & 4 Plastic Grommet Part #012-0616
1	010-3362	Modesty Panel
1	010-3361	Modesty Panel Shelf
1	022-2041	Left Side Panel
1	022-2042	Right Side Panel
2	010-3356	Inner Shelf
1	010-3357	Bottom Shelf
1	022-1759	Right Upper Outer Pedestal Assy.
1	022-1770	Right Lower Inner Pedestal Assy.
1	022-1758	Left Upper Outer Pedestal Assy.
1	022-1769	Left Lower Inner Pedestal Assy.
1	010-2469	Shelf Support Brace
1	010-2467	Access Door (Modesty Panel)
1	010-3358	Side Panel, CPU
1	010-3359	Bottom Shelf, CPU
1	010-3360	Extension Side Panel, CPU
1	010-2477	Adjustable Divider, CPU

HARDWARE LIST

Ref	Qty	Part #	Description
AA	25	030-0325	1/4-20 x 1/2" Combo Truss Screw
BB	16	030-0304	1/4-20 x 5/8" Combo Truss Screw
CC	12	030-0240	1/4" External Lock Washer
DD	4	030-0168	#8 x 1/2" Sheet Metal Screw
EE	23	030-0402	#10-32 x 5/8" Black Combo Screw
FF	14	030-0357	10-32 Flanged Hex Serrated Nut
GG	16	030-1032	5/16-18 x 3/4" Self Tap Hex Screw
HH	6	030-0256	1/4 - 20 Flange Nut
	1	010-1106	Hex Wrench
	2	015-0086	5" Plate Caster w/o Brake
	2	015-0087	5" Plate Caster w/ Brake

TOOLS REQUIRED

- Phillips Screwdriver
- Flat Screwdriver
- Hex Wrench (Provided)

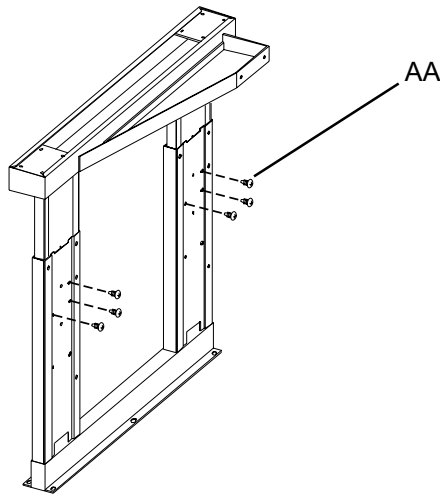

FIGURE 1

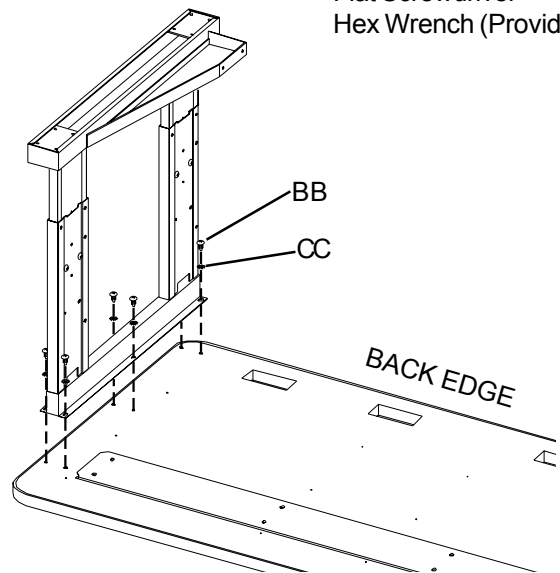
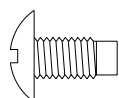

FIGURE 2

STEP 1

Determine desired final height of table, (**NOTE:** Allow 6" for casters), and set desired height. Install screws (AA) in each leg (**Figure 1**). Lay wood top on a clean flat surface with holes facing up (top of carton works well). Position legs with holes facing inward on wood top and loosely attach with screws (BB) and washers (CC) as shown in **Figure 2**.



AA

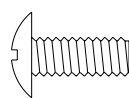

BB



CC

FOR YOUR CONVENIENCE:

If you have purchased accessories UCSAMS, Monitor Shelf, or UCSTVS, TV Shelf, it would be helpful to drill the holes for the accessories now. For UCSAMS, refer to STEP 1 on that instruction sheet. For UCSTVS, refer to STEP 3 on that instruction sheet.

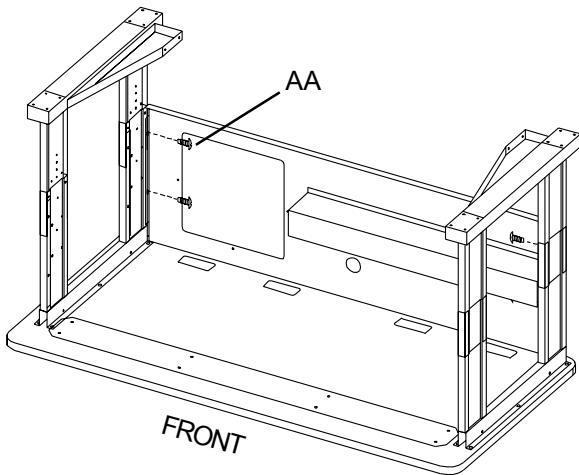

FIGURE 3

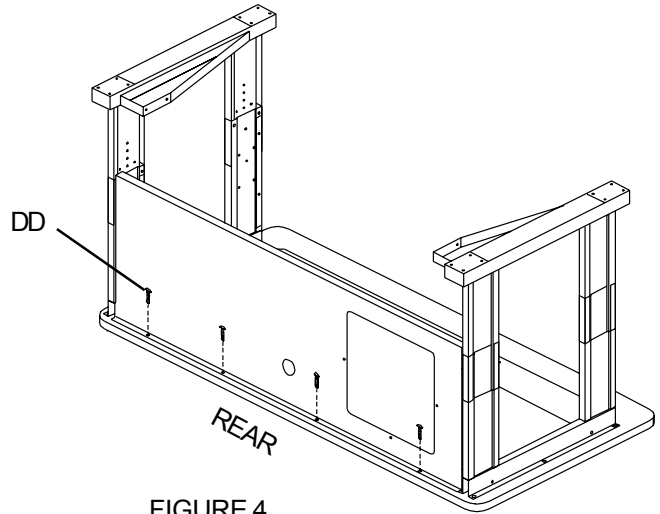

FIGURE 4

STEP 2

Loosely attach modesty panel to legs with screws (AA) as shown in **Figure 3**. Attach to wood top with screws (DD) as shown in **Figure 4**. Now tighten all screws into wood top and legs.

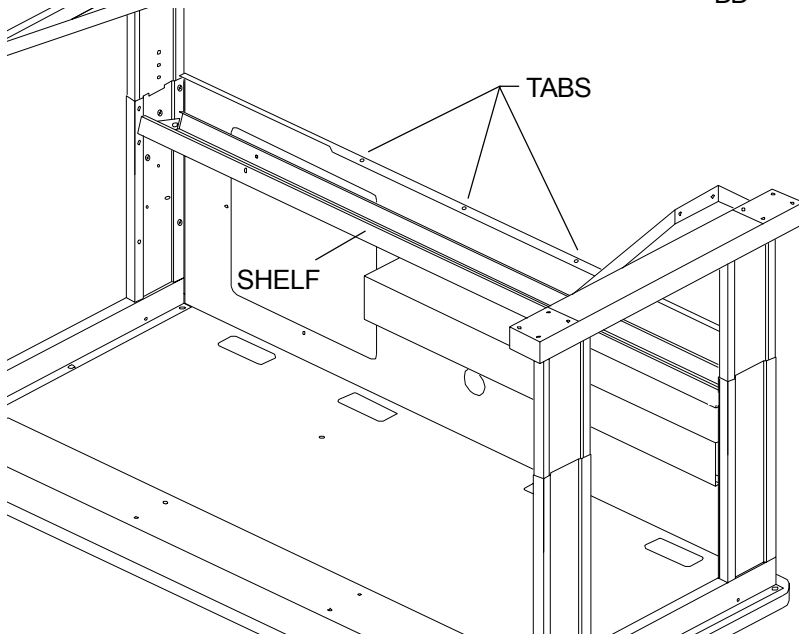

FIGURE 5

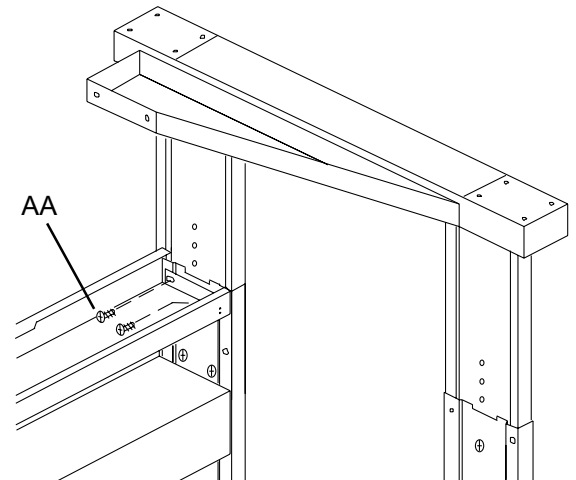
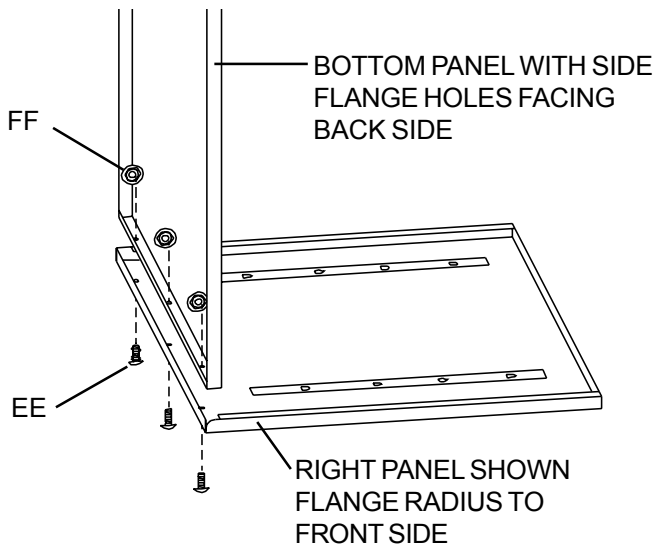

FIGURE 6

STEP 3

Tilt modesty panel shelf with flanges facing upward and logo facing front; hook onto tabs in modesty panel (**Figure 5**). **NOTE:** It may be necessary to open the three tabs on the modesty panel up a bit with a flat screwdriver. Attach at corners with screws (AA) as shown in **Figure 6**.

NOTE: For ease of assembly, remove the excess paint from the legs by driving screws into holes along first then proceed with modesty panel assembly.



STEP 4a

Assemble cabinet by standing the bottom shelf on its side with flanges facing out; attach right side panel with radius facing front with screws (EE) and nuts (FF) as shown.

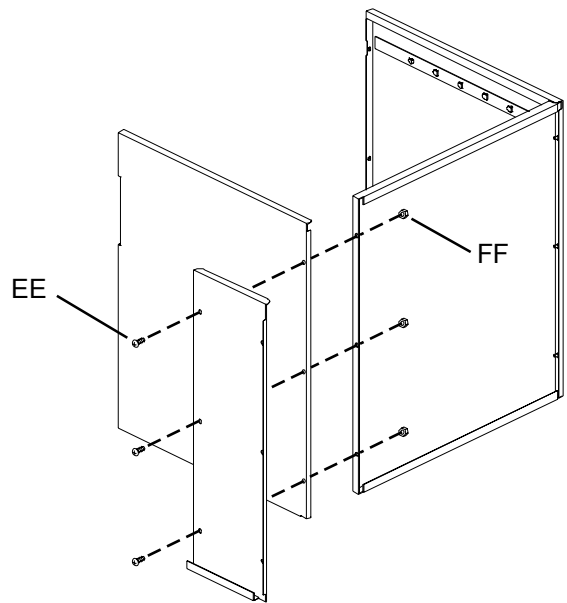

STEP 4b

To attach left side panel and extension panel, stand up the bottom and right side panels as shown. Position and secure the left side panel and the extension panel in the same manner as the right panel.

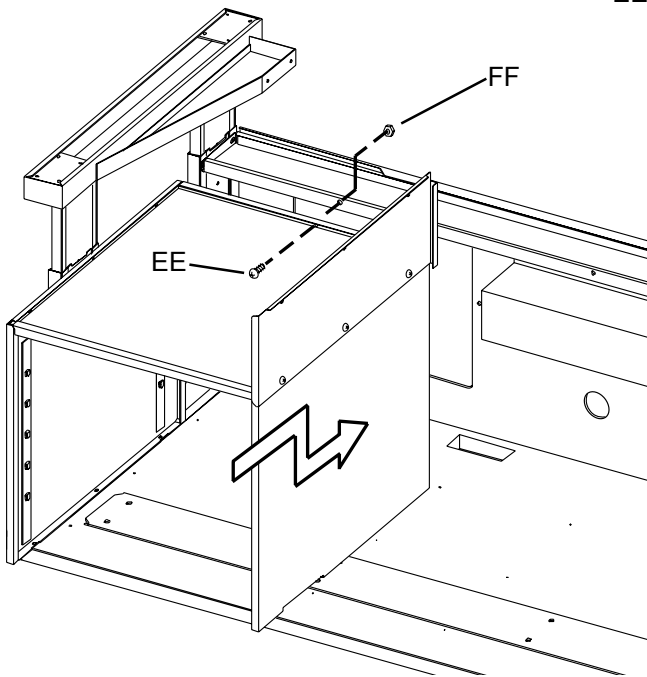
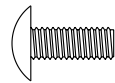

FIGURE 7

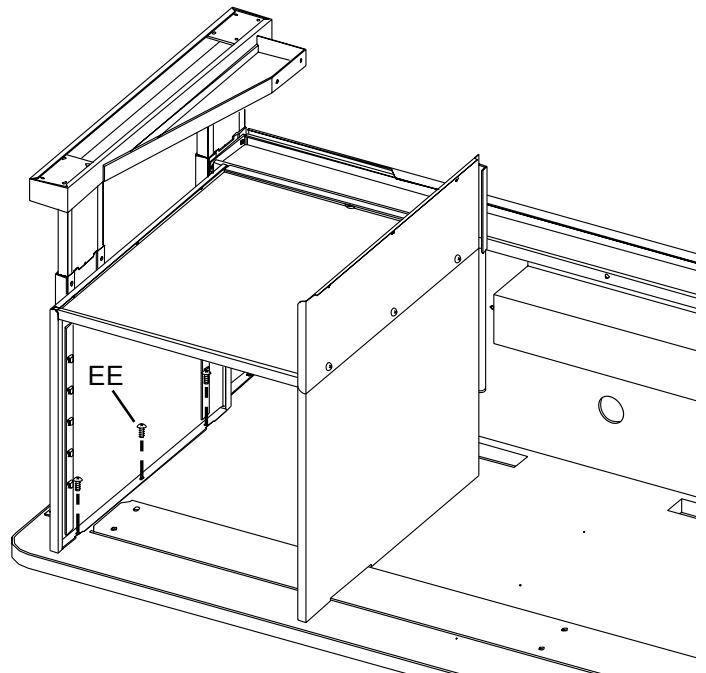

FIGURE 8

STEP 5

Position cabinet onto unit with holes in bottom shelf and modesty panel shelf lining up. Secure through hole with screw (EE) and nut (FF) as shown in **Figure 7**. Secure cabinet sides to wood top using screws (EE) as shown in **Figure 8**. Position the cabinet shelves in desired location once unit is upright.

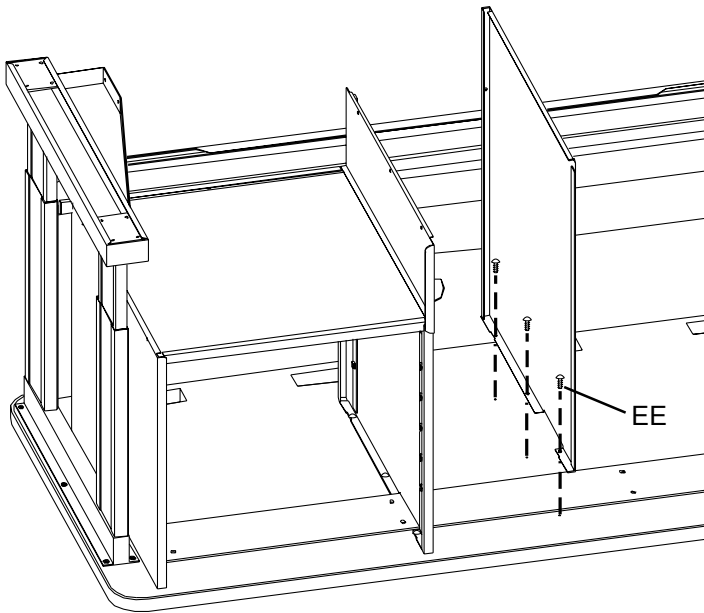

FIGURE 9

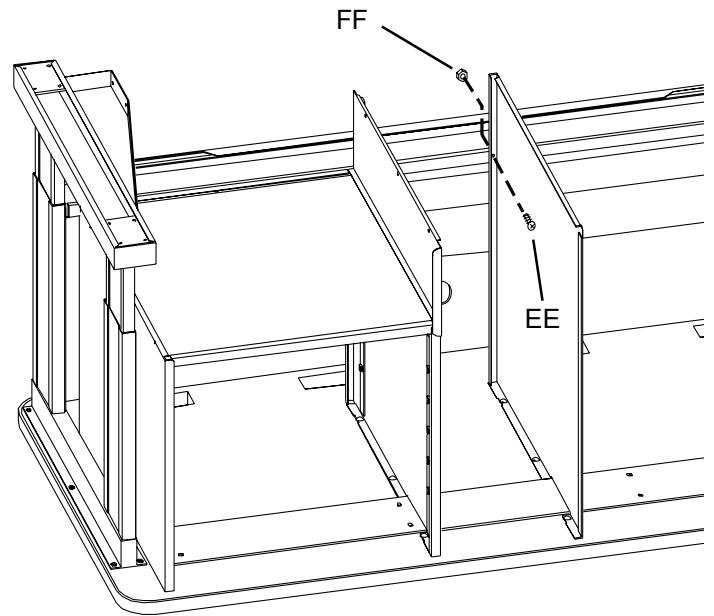
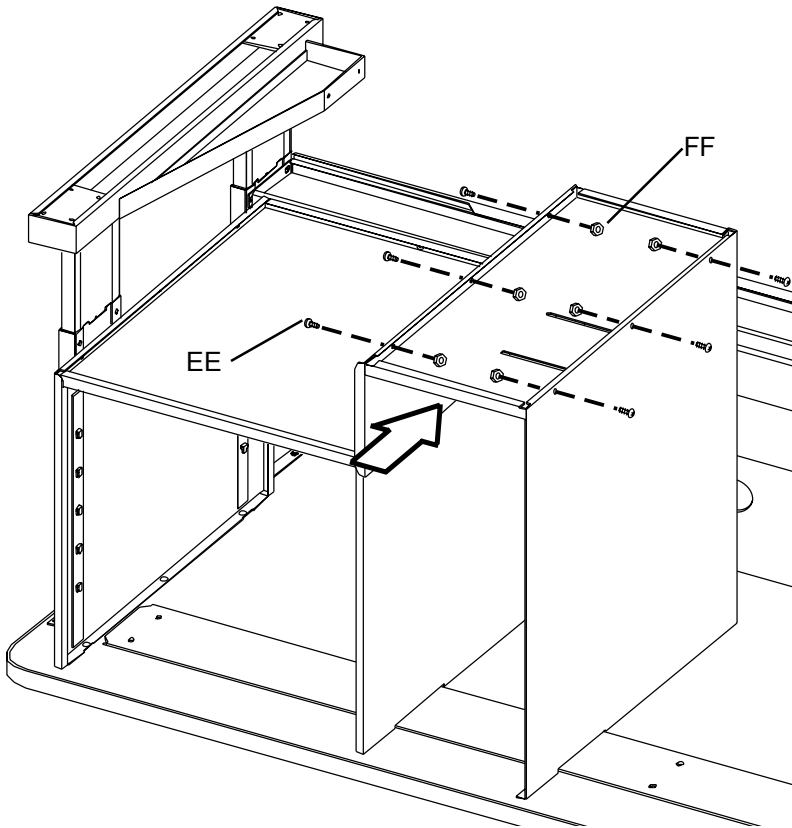

FIGURE 10

STEP 6

LOOSELY attach side panel to UCS925 wood top using screws (EE) as shown in **Figure 9**. Then **LOOSELY** attach side panel to UCS925 modesty panel shelf using screw (EE) and nut (FF) as shown in **Figure 10**. Do not tighten hardware until Step 7 is completed.



STEP 7

Slide the bottom panel between extension panel until the mounting holes align. Install screws (EE) and nuts (FF) as shown. **TIGHTEN ALL HARDWARE AT THIS TIME.**

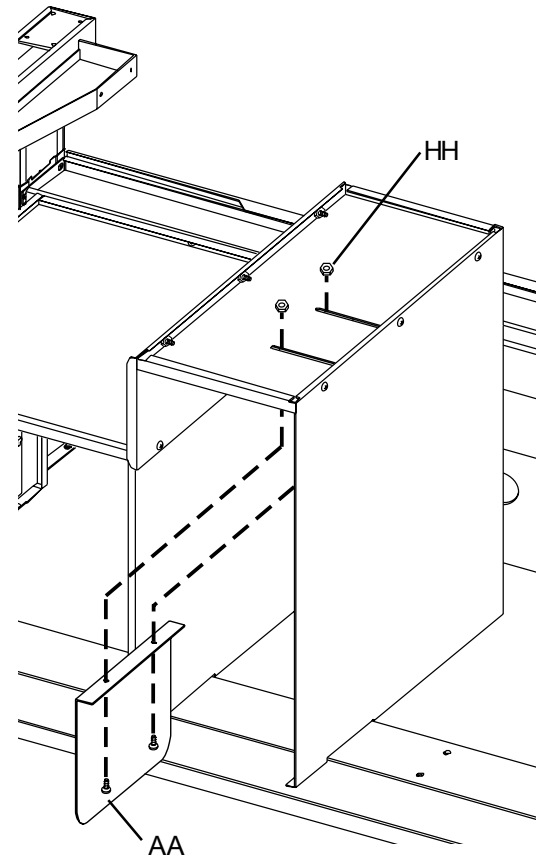

STEP 8

The adjustable divider is used to hold CPU in place. Attach divider in desired location using screws (AA) and nuts (HH) as shown.

NOTE: Some larger CPU models may be large enough that the divider will not be necessary to use.

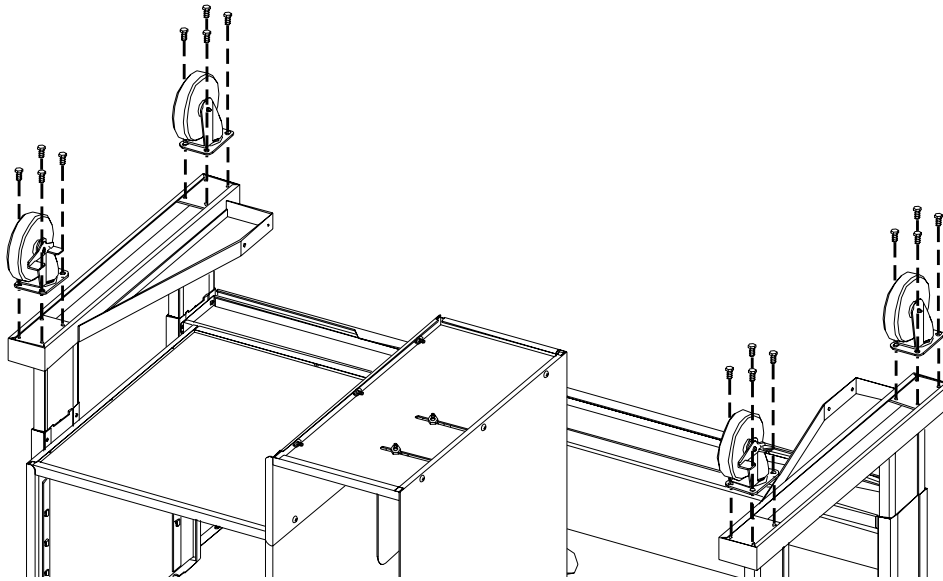

STEP 9

Position casters in each corner of pedestals. Attach with bolts (GG) and use hex wrench (provided) to fasten as shown.

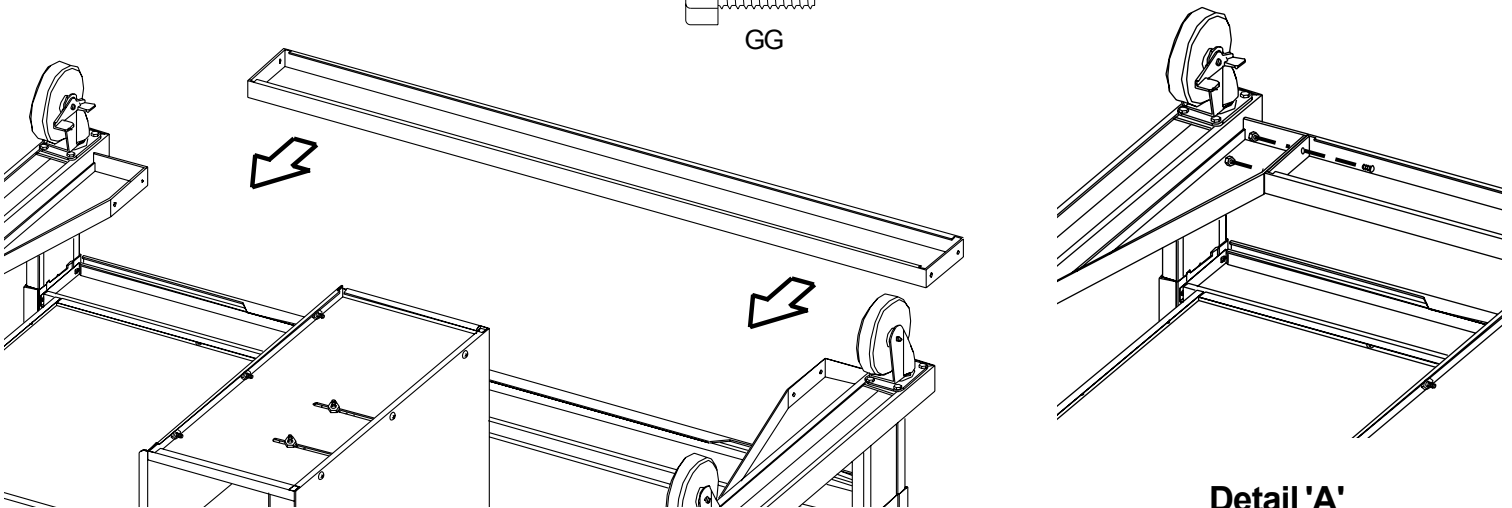
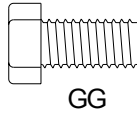

STEP 10

Attach the shelf brace with screws (BB) and nuts (HH) as shown.

Detail 'A'

Attach the shelf brace with screws (BB) and nuts (HH) as shown.

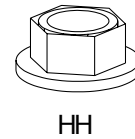

SAFETY WARNING
Note: TWO PERSON
ASSISTANCE REQUIRED

STEP 11

Carefully turn the table over to an upright position.

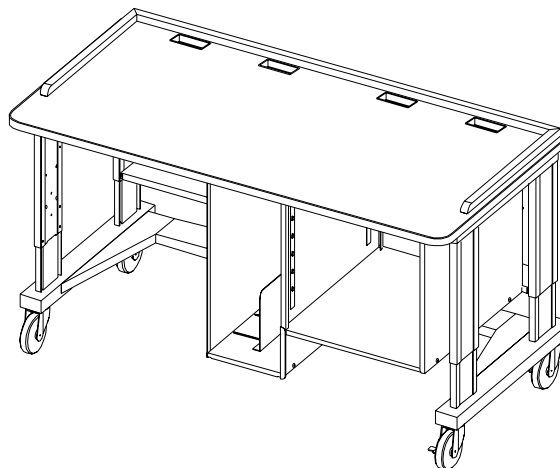

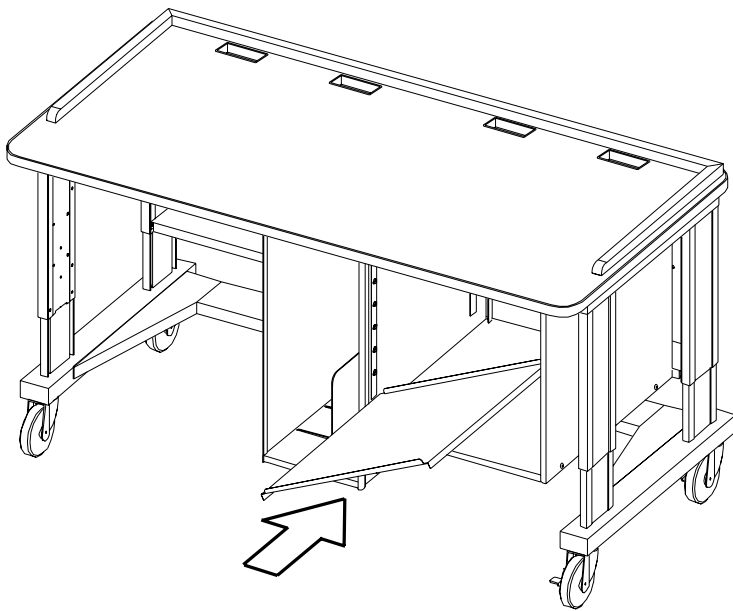

FIGURE 11

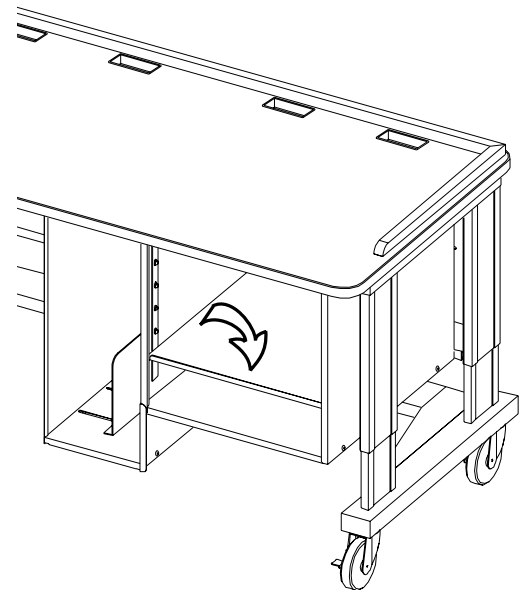

FIGURE 12

STEP 12

Position the cabinet shelf in desired location by hooking the side flange of the shelf onto the side panel tabs as shown in **Figure 11**. Pivot the shelf into the adjoining side panel tabs to a level position as shown in **Figure 12**. Repeat this step again for second shelf.

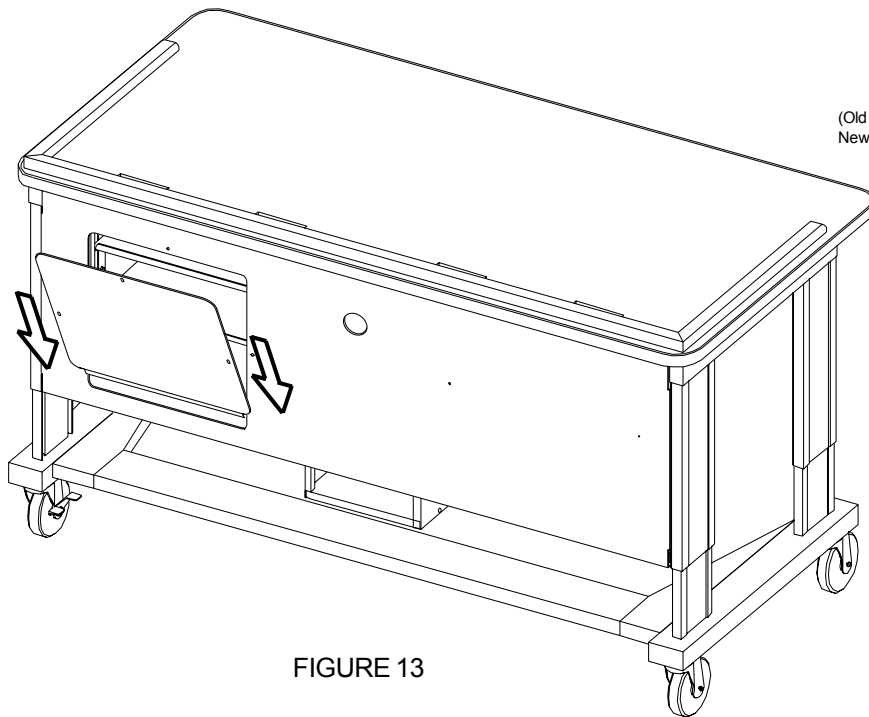

FIGURE 13

(Old Style Top Shown
New Style Has No Top Rails)

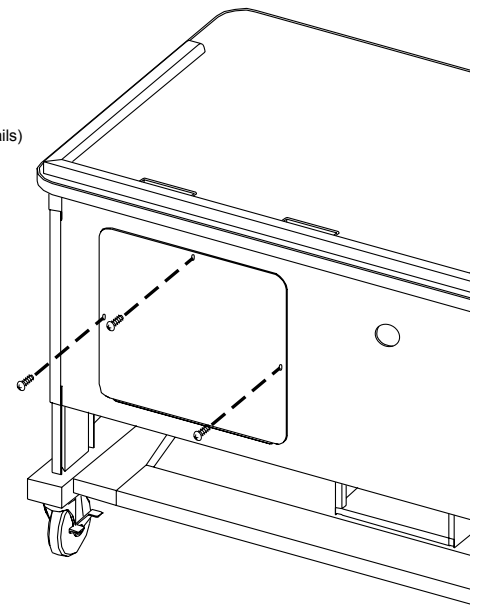

FIGURE 14

STEP 13

Attach access door from behind the unit as shown in **Figure 13**. **NOTE:** The access door is meant for easy access to wires/cables of your component pieces. It might be easier to position components on shelves and then attach access door using screws (AA) as shown in **Figure 14**.

Bretford
11000 Seymour Avenue
Franklin Park, IL 60131
TEL: 847.678.2545
800.521.9614
FAX: 847.678.0852
800.343.1779

Bretford Ltd.
2 Etcgate
110 Windsor Road
Slough, Berkshire SL1 2JA England
TEL: 01753 216531
FAX: 01753 539478